

THE TANK AND MECHANIZED INFANTRY BATTALION TASK FORCE

CONTENTS

	PAGE
PREFACE	iv
CHAPTER 1. INTRODUCTION	1-1
Section I. Mission, Capabilities, and Limitations	1-2
*Section II. Battalion Task Force on the AirLand Battlefield	1-3
Section III. Organization and Functions	1-7
Section IV. Battlefield Operating Systems	1-10
Section V. Special Operational Environments	1-13
CHAPTER 2. COMMAND AND CONTROL	2-1
Section I. Command and Control Responsibilities	2-2
Section II. Command and Control Facilities	2-7
Section III. Command and Control Process	2-10
Section IV. Intelligence Preparation of the Battlefield	2-22
Section V. Command and Control Communications	2-29
Section VI. Other Command and Control Procedures	2-33
CHAPTER 3. OFFENSIVE OPERATIONS	3-1
Section I. Fundamentals of Offensive Operations	3-2
Section II. Threat Defensive Doctrine	3-16
Section III. Planning for Offensive Operations	3-19
*Section IV. Conducting Attacks	3-42
Section V. Other Offensive Operations	3-62

DISTRIBUTION RESTRICTION: Distribution authorized to US Government agencies and their contractors only, to protect the technical and operational information from automatic dissemination under the International Exchange Program or by other means. This determination was made on 19 February 1987. Other requests will be referred to Commandant, US Infantry School, ATTN: ATSH-B, Ft. Benning, GA 31905-5410.

DESTRUCTION NOTICE: Destroy by any method that will prevent disclosure of contents or reconstruction of the document.

* This publication supersedes FM 71-2(HTF), 30 June 1977.

		PAGE
CHAPTER 4.	DEFENSIVE OPERATIONS	4-1
Section I.	Fundamentals of the Defense	4-2
Section II.	Threat Offensive Doctrine	4-7
* Section III.	Planning for Defensive Operations	4-8
Section IV.	Types of Defense	4-30
Section V.	Reserve Operations	4-42
Section VI.	Other Defensive Operations and Techniques	4-47
 CHAPTER 5.	 OTHER TACTICAL OPERATIONS	 5-1
Section I.	Retrograde Operations	5-2
Section II.	Passage of Lines	5-20
Section III.	Relief Operations	5-28
Section IV.	Breakout from Encirclement	5-33
Section V.	Linkup	5-39
Section VI.	Hasty Water Crossings	5-43
Section VII.	Guard Operations	5-51
Section VIII.	Obstacle Reduction	5-60
 CHAPTER 6.	 COMBAT SUPPORT	 6-1
Section I.	Relationships and Responsibilities	6-2
Section II.	Indirect Fire Support	6-3
Section III.	Tactical Air Support	6-17
Section IV.	Army Aviation Support	6-22
Section V.	Air Defense Support	6-24
Section VI.	Engineer Support	6-29
Section VII.	Nuclear, Biological and Chemical Support	6-32
Section VIII.	Intelligence and Electronic Warfare Support	6-41
 CHAPTER 7.	 COMBAT SERVICE SUPPORT	 7-1
Section I.	CSS Functions and Organization	7-2
Section II.	Planning	7-7
Section III.	Operations	7-11
Section IV.	Supply	7-23
Section V.	Maintenance	7-28
Section VI.	Field Services	7-33
* Section VII.	Personnel and Health Services Support	7-35
Section VIII.	Reconstitution	7-40
 * APPENDIX A.	 MECHANIZED INFANTRY AND ARMORED LIGHT INFANTRY, AND SPECIAL OPERATIONS FORCES OPERATIONS	 A-1
APPENDIX B.	COMBAT ORDERS	B-1
APPENDIX C.	TACTICAL ROAD MARCHES AND ASSEMBLY AREAS	 C-1
* APPENDIX D.	DIRECTED-ENERGY WEAPONS	D-1
* APPENDIX E.	OPERATIONS IN NUCLEAR, BIOLOGICAL, AND CHEMICAL CONDITIONS	 E-1

		PAGE
* APPENDIX F.	SNIPER EMPLOYMENT	F-1
* APPENDIX G.	EMPLOYMENT OF THE ANTIARMOR COMPANY	G-1
* APPENDIX H.	FRATRICIDE AVOIDANCE	H-1
* GLOSSARY		Glossary-1
* REFERENCES		References-1
INDEX		Index-1

PREFACE

This manual describes the doctrinal and tactical employment of the tank and mechanized infantry battalion task force on the AirLand Battlefield. FM 71-2 is the doctrinal foundation for and governs the development of equipment, training, and structure as pertains to tank and mechanized infantry battalions.

This manual reflects and supports the Army's AirLand Battle doctrine as stated in FM 100-5. It emphasizes synchronization of the battalion task force fight through the integrated planning and coordinated employment of all combat support and combat service support assets. The tank and mechanized infantry battalion task force is organized and equipped for combat specifically to destroy enemy forces by mounted combat or by a combination of mounted and dismounted combat.

This manual is written for the battalion task force commander, his staff, company commanders, organic specialty platoon leaders, and supporting units. Readers should be familiar with FM 100-5, FM 101-5, FM 101-5-1, FM 71-3, and FM 71-1. Tactical principles are provided to guide the effective employment of the battalion task force. Examples are provided to illuminate principles, not to serve as prescriptive responses to factual situations. The principles and tactics in this manual have been validated over time through the experiences of countless units and individual soldiers.

*This publication implements the following international agreements: QSTAG 506 and 567; STANAG 2014 (Edition 5); STANAG 2041 (Edition 3), paragraph 6; STANAG 2082 (Edition 5), paragraphs 5a-c and 6, and Annex A, and STANAG 2129 (Edition 3), paragraph 6c(1).

*Throughout this manual, the term "heavy force" should be changed to "mechanized infantry and armored force."

*The proponents of this publication are US Army Infantry School and US Army Armor School. Submit changes for improving this publication on DA Form 2028 (Recommended Changes to Publications and Blank Forms) directly to Commandant, US Army Infantry School, ATTN: ATSH-ATD, Fort Benning, Georgia 31905; or Commandant, US Army Armor School, ATTN: ATSB-SBD-D, Fort Knox, Kentucky 40121-5211.

Unless this publication states otherwise, masculine nouns and pronouns do not refer exclusively to men.

Change 1

**HEADQUARTERS
DEPARTMENT OF THE ARMY
Washington, DC, 17 August 1994**

The Tank and Mechanized Infantry Battalion Task Force

1. Change FM 71-2, September 1988, as follows:

Remove old pages

i through iv

1-1 through 1-6

3-51 through 3-52

4-25 through 4-26

7-1 through 7-2

7-39 through 7-41

A-1 through A-6

D-1 through D-4

E-1 through E-12

Insert new pages

i through iv

1-1 through 1-6.1

3-51 through 3-52

4-25 through 4-26

7-1 through 7-2

7-39 through 7-41

A-1 through A-30

D-1 through D-11

E-1 through E-12

F-1 through F-13

G-1 through G-47

H-1 through H-9

Glossary-1 through Glossary-10
References-1 through References-3

Glossary-1 through Glossary-11
References-1 through References-3

2. A star (*) marks new or changed material.
3. File this transmittal sheet in front of the publication.

DISTRIBUTION RESTRICTION: Approved for public release; distribution is unlimited.

By Order of the Secretary of the Army:

Official:

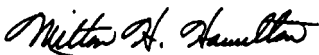
MILTON H. HAMILTON
*Administrative Assistant to the
Secretary of the Army*

GORDON R. SULLIVAN
*General, United States Army
Chief of Staff*

DISTRIBUTION:

Active Army, USAR and ARNG: To be distributed in accordance with DA Form 12-11E, requirements for FM 71-2, The Tank and Mechanized Infantry Battalion Task Force (Qty rqr block no. 0506).

CHAPTER 1

INTRODUCTION

Tank and mechanized infantry battalion task forces are organized to fight and win engagements on any part of the battlefield in conventional, nuclear, or chemical environments. They combine the efforts of their company teams and combat support to perform tactical missions as part of a brigade or division operation. The key to victory is to quickly mass the combat power of maneuver company teams and integrate and synchronize combat support (CS) and combat service support (CSS) combat multipliers.

CONTENTS	
PARAGRAPH	PAGE
Section I. MISSION, CAPABILITIES, AND LIMITATIONS. . .	1-2
1-1 Mission	1-2
1-2 Capabilities	1-2
1-3 Limitations	1-3
Section II. BATTALION TASK FORCE ON THE AIRLAND BATTLEFIELD	1-3
*1-4 Tenets of Army Operations	14
1-5 Battalion Battlefield Focus	1-6.1
Section III. ORGANIZATION AND FUNCTIONS	1-7
1-6 Battalion Commander	1-7
1-7 Subordinate Commanders	1-8
1-8 Battalion Staff	1-8
1-9 Scout Platoon	1-8
1-10 Mortar Platoon	1-9
1-11 Communications Platoon	1-9
1-12 Support Platoon	1-9
1-13 Medical Platoon	1-9
1-14 Maintenance Platoon	1-9
1-15 Combat Support.	1-9
Section IV. BATTLEFIELD OPERATING SYSTEMS	1-10
1-16 Operating Systems	1-10
1-17 Human Dimension.	1-13
Section V. SPECIAL OPERATIONAL ENVIRONMENTS	1-13
1-18 Urban Area Operations	1-14
1-19 Desert Operations	1-14
1-20 Jungle Operations.	1-14
1-21 Mountain Operations	1-14
1-22 Cold Weather Operations	1-15

Section I. MISSION, CAPABILITIES, AND LIMITATIONS

Mechanized infantry battalions and tank battalions are organized, equipped, and trained to accomplish compatible missions; each type battalion has unique capabilities and limitations.

1-1. MISSION

- a. The missions of mechanized infantry and tank battalions in their pure configurations are as follows:
 - (1) **Mechanized infantry battalion.** Their mission is to close with the enemy by means of fire and maneuver in order to destroy or capture him, or to repel his assault by fire, close combat, and counterattack.
 - (2) **Tank battalion.** Their mission is to close with and destroy enemy forces using fire, maneuver, and shock effect, or to repel his assault by fire and counterattack.
- b. Battalion task forces accomplish missions and tasks as part of a brigade's operation. Occasionally, task forces will conduct operations directly under the control of a division or an armored cavalry regiment such as when they are participating in the higher headquarters covering force, acting as a reserve, or forming a tactical combat force in rear area operations.

1-2. CAPABILITIES

- a. The capability of the tank and mechanized infantry battalions is increased through task organization. Based on his estimate of the situation, the brigade commander task-organizes tank and mechanized infantry battalions by cross-attaching companies between these units. As a rule, cross-attachment is done at battalion, because battalion has the necessary command and control and support capabilities to employ combined arms formations. The brigade commander determines the mix of companies in a task force. Similarly, the task force commander's estimate may require cross-attaching platoons to form one or more company teams for specific missions.
- b. Tank and mechanized infantry battalion task forces apply their mobility, firepower, and shock effect—
 - To conduct sustained combat operations in all environments.
 - To accomplish rapid movement and limited penetrations.
 - To exploit success and pursue a defeated enemy as part of a larger formation.

- To conduct security operations (advance, flank, or rear guard) for a larger force.
- To conduct defensive, retrograde, or other operations over assigned areas.
- To conduct offensive operations.

1-3. LIMITATIONS

- a. Because of the high density of tracked vehicles, the battalion has the following limitations:
 - Mobility and firepower are restricted by urban areas, dense jungles and forests, very steep and rugged terrain, and significant water obstacles.
 - Strategic mobility is limited by substantial quantities of heavy equipment.
 - Consumption of supply items is high, especially Classes III, V, and IX.
- b. Battalions are task-organized according to mission, and they are routinely augmented to improve engineer, fire support, air defense, intelligence, and CSS capabilities.

Section II. BATTALION TASK FORCE ON THE AIRLAND BATTLEFIELD

The foundation of AirLand Battle doctrine at the task force level is classical maneuver warfare. In its simplest form, maneuver warfare involves using a part of the force to find, then fix or contain the enemy, while the remainder of the force attacks his weakest point—usually a flank or the rear. The goal is to mass enough combat power at the critical place and time to destroy the enemy or threaten him with destruction, while preserving freedom for future action.

The task force commander must understand the intent of the brigade commander and division commander so he can properly employ his force. The task force commander develops his intent and concept and accepts risks to achieve decisive results. He seizes the initiative early and conducts offensive action aimed at imposing his will on the enemy. The objective of his maneuver is to position strength against weakness, throw the enemy off balance, and aggressively follow-up to complete defeat and destruction of the enemy.

*1-4. TENENTS OF ARMY OPERATIONS

The Army's success on and off the battlefield depends on its ability to operate in accordance with five basic tenets: **initiative**, **agility**, **depth**, **synchronization**, and **versatility**. A tenet is a basic truth held by an organization. The fundamental tenets of Army operations doctrine describe the characteristics of successful operations. All training and leadership doctrine and all combat, combat support, and combat service support doctrine derive directly from, and must support, the fundamental tenets. The US Army believes that its five basic tenets are essential to victory. In and of themselves they do not guarantee victory, but their absence makes it difficult and costly to achieve. (See FM 100-5.)

- a. **Initiative.** Initiative sets or changes the terms of battle by action and implies an offensive spirit in the conduct of all operations. Applied to the force as a whole, initiative requires a constant effort to force the enemy to conform to commanders' operational purposes and tempos, while retaining freedom of action. It means depleting the enemy's options, while still having options of their own. This requires leaders to anticipate events on the battlefield so that they and their units can act and react faster than the enemy. Applied to individual soldiers and to leaders, initiative requires a willingness and ability to act independently within the framework of the higher commander's intent.
 - (1) In battle, initiative requires the decentralization of decision authority to the lowest practical level. At the same time, decentralization risks some loss of synchronization. Commanders constantly balance these competing risks, recognizing that loss of immediate control is preferable to inaction. Decentralization demands well-trained subordinates and superiors who are willing to take risks.
 - (2) In operations other than war, initiative implies controlling the environment rather than letting the environment control events. In responding to a natural disaster, commanders direct their forces to the critical points or facilities where prompt action is needed to stabilize the environment. The objective is to allow local governments to assume control at an appropriate time while the community regains control of basic services. Commanders direct their military activities in combination with other elements of national and coalition power to restore stability.
- b. **Agility.** Agility is the ability of friendly forces to react faster than the enemy and is a prerequisite for seizing and holding the initiative. It is as much a mental as a physical quality. Greater quickness permits the rapid concentration of friendly strength against enemy vulnerabilities. Forces will need to mass their effect rapidly so that by the time the enemy reacts to one action, another has taken its place, disrupting the enemy's plans and leading to late, uncoordinated, and piecemeal responses. This process of successive massing against locally weaker or unprepared enemy forces enables smaller forces to disorient, fragment, and eventually defeat much larger opposing formations. To achieve such a defeat, leaders and units must be agile.

- (1) In operations other than war, as commanders perceive changes to their environment, they devise imaginative methods of applying their resources to those changes and act quickly to gain or maintain control of the environment. For example, Army forms in disaster relief operations can use tactical vehicles and communication systems to reach isolated locations, to direct efforts, and to restore services to supplement the efforts of local governments whose normal resources are overwhelmed.
 - (2) In peacekeeping operations, Army forces might defuse conditions that would otherwise lead to a resumption of fighting by recognizing the inherent dangers and by resolving grievances before they ignite into open combat. A situational awareness that perceives and anticipates changes in the environment, combined with the ability to act quickly within the intent of higher commanders, leads to an agility in operations other than war that is vital to successful outcomes.
- c. **Depth.** Depth is the extension of operations in time, space, resources, and purpose. These factors vary by echelon and by constraints given to commanders. What is most important, however, is the fact that in any operation, the Army must have the ability to gain information and influence operations throughout the depth of the battlefield. This ability highlights the joint nature of deep operations, which means participation by the other services.
- (1) In offensive and defensive tactical actions, commanders fight the enemy throughout the depth of his disposition with fires and with attacks on his flanks and rear. They attack committed and uncommitted forces and synchronize the attack of enemy artillery in depth with close operations. Such in-depth operations degrade the enemy's freedom of action, reduce his flexibility and endurance, and upset his plans and coordination. Most importantly, these operations prevent the enemy from impacting on friendly actions. Commanders retain reserves and adjust their main effort to exploit tactical opportunities and carry the fight into the depths of the enemy's formations or defenses. At the same time, commanders guard their own freedom of action by protecting their forces and the means needed to sustain combat operations.
 - (2) In operations other than war, depth extends activities in time, space, resources, and purpose to affect the environment and the conditions that are to be resolved. Seldom are short-term situations conclusive. Commanders envision simultaneous activities and sequential stages that lead to a long-term outcome. For example, to solve the problem of feeding the local population, commanders may set up kitchens and distribute food in the first stage, assist in the reestablishment of commercial food distribution points in the second stage, and finally assist in improving road networks as the local government regains the ability to provide a steady supply of food. Similarly, peacekeeping operations may begin with an initial objective of observing a cease-fire, then move to support of an economic recovery program, and finally conclude in

support of an international agency program that results in cultural assimilation and the resolution of the underlying conflict. Just as in war, commanders anticipate future situations and decide how to coordinate activities in depth that will achieve the desired end state.

- d. **Synchronization.** Synchronization is arranging activities in time and space to mass at the decisive point and achieve a desired effect. For example, integrating the activities of intelligence, logistics, and fire support with maneuver leads to synchronized operations.
 - (1) Synchronization includes, but is not limited to, the massed effects of combat power at the point of decision. Some of the activities that commanders synchronize in an operation, such as jamming enemy communications, suppressing enemy air defenses, and shifting reserves, might occur before the decisive moment. They may take place at locations distant from one another. Though separated in time and space, these activities must be well synchronized if their combined effects are to be felt at the decisive time and place. Synchronization seeks to gain overwhelming combat power.
 - (2) Synchronization usually requires explicit coordination among the various units and activities participating in any operation. By itself, however, such coordination is no guarantee of synchronization unless commanders first visualize the consequences to be produced and how they must sequence activities to produce these consequences. Staffs must understand their commander's intent since they make a large part of the synchronization plan happen. Synchronization thus takes place first in the minds of commanders and then in the actual planning and coordination of movements, fires, and supporting activities. Rehearsals are key to successful execution of synchronized operations.
- e. **Versatility.** Versatility is the ability of units to meet diverse mission requirements. Commanders must be able to shift focus, tailor forces, and move from one role or mission to another rapidly and efficiently. Versatility implies a capacity to be multifunctional, to operate across the full range of military operations, and to perform at the tactical, operational, and strategic levels.
 - (1) Versatility is the ability of tactical units to adapt to different missions and tasks, some of which may not be on unit mission-essential task lists (METLs). Army forces have always been versatile; in World War II, Korea, and Vietnam, they adapted quickly to the environment and to the tactics of the enemy. In a force-projection army, however, the demands for versatility increase. Operations Just Cause, Desert Shield, Desert Storm, and Provide Comfort introduced Army forces to dynamic environments that called for quick, successful action across a wide range of war and operations other than war. Forces must be prepared to move rapidly from one geographical region to another and from one type of warfare to another in quick succession.

(2) Versatility denotes the ability to perform in many roles and environments during war and operations other than war. It allows for the smooth transition from one mission to another. Versatility requires competence in a variety of missions and skills. This suggests that all military organizations must have the ability to organize in different combinations of units, and it also suggests that they must have the capacity to redeploy from one area or region to another without the loss of focus. Versatility is the result of well-led, well-trained, and well-equipped forces, high standards, and detailed planning. Versatility ensures that units can conduct many different kinds of operations, either sequentially or simultaneously, with the same degree of success.

1-5. BATTALION BATTLEFIELD FOCUS

- a. Battalion is the lowest echelon at which firepower, maneuver, intelligence, and support are combined under a single commander. Battalions normally fight enemy forces they can see and engage—this defines an area of operations extending from less than 100 meters in forests, urban areas, or close terrain, out to about 5 to 6 kilometers from the battalion's direct and indirect fire weapon systems.

- b. During the offense, the battalion task force is expected to defeat a defending enemy company. The close fight consists of breaching obstacles, penetrating defenses, and defeating defending platoons. Following any penetration, the battalion prepares to fight enemy battalion reserves (platoon or company). The battalion has no rear battle and responds to rear threats as a part of the close fight. Battalion reserves are designated as required to meet changing situations. Reserves provide weight to the main effort. The task force provides security and reconnaissance to support attacking company teams. During the battalion close fight, the brigade conducts its deep fight against enemy regimental reserves, then fights enemy units defending in subsequent defensive positions.
- c. During the defense, the battalion task force is expected to defend against and defeat a threat regiment. The battalion task force close fight consists of subordinate companies defeating the companies of the enemy first echelon battalions and then defeating the companies of second echelon battalions. The battalion has no deep fight, but may be charged with the execution of the fight against follow-on enemy battalions. The battalion responds to defensive rear threats, as part of the close fight. The battalion normally designates a company-size reserve as a counterattack force. Battalion employs defensive security measures in concert with the brigade plan. The brigade deep fight supports the battalion close fight by interdicting the follow-on battalions, then shifting to the lead battalions of the second echelon regiment.

Section III. ORGANIZATION AND FUNCTIONS

A tank or mechanized infantry battalion consists of pure companies under the command of a battalion headquarters. It participates in brigade or division operations in accordance with the principles and concepts set forth in FM 71-3 and FM 71-100.

1-6. BATTALION COMMANDER

- a. The fighting characteristics of a battalion are a reflection of the character of the battalion commander. Bold and tenacious battalion commanders have bold and tenacious battalions. If a commander is tactically skillful and innovative, history supports that most of his battalion's missions will be successful and his battalion will suffer minimum casualties. Battalion commanders who possess the technical, tactical, and leadership skills, and

who develop teams out of individual soldiers and units, will win — even if outnumbered. Battalion commanders who are also competent and courageous can successfully lead soldiers on the dynamic, lethal, and chaotic modern battlefield.

- b. Because the battalion task force commander must organize his task force based on the mission, enemy, terrain and weather, troops and time available (METT-T), he must have an understanding of all of the tools at his disposal. Then, he must effectively combine these tools for each tactical situation. The commander achieves maximum effectiveness from the battalion task force by being aware of all of his assets and knowing how to employ them.

1-7. SUBORDINATE COMMANDERS

The company team commanders and special-purpose platoon leaders directly influence the battle by employing their fire and maneuver elements in a way that accomplishes the mission. They are the commander's principal assistants for fighting the battle. They must understand the commander's concept and know the capabilities and employment techniques of their combat assets as well as the combat support assets provided to them by the task force commander.

1-8. BATTALION STAFF

The battalion is the lowest tactical echelon with a staff. Small but essential, they assist the commander in doing all those things necessary to coordinate the battle and to ensure adequate combat and combat service support to allow for continuous operations. The commander is then free to fight the battle. Supply, maintenance, communications, administration, and reporting are all supervised by the staff. The staff normally conducts much of its business in accordance with SOPs. The staff ensures continuous support to the company teams to allow them to fight the battle.

1-9. SCOUT PLATOON

The battalion scout platoon performs reconnaissance, provides limited security, and assists in controlling movement of the battalion task force. The platoon is not organized or equipped to conduct independent offensive, defensive, or retrograde operations. It operates as part of the battalion and should be assigned missions that capitalize on its reconnaissance capabilities. The scout platoon is

one of the commander's primary sources of combat intelligence before the battle and is his eyes and ears during the battle. (See FM 17-98.)

1-10. MORTAR PLATOON

Mortars are organic to the battalion. They are high-angle, relatively short-range, area fire weapons, well suited for providing close indirect-fire support to maneuver units. (See FM 7-90.)

1-11. COMMUNICATIONS PLATOON

The battalion communications platoon is responsible for establishing and operating the battalion radio and wire communications systems. In addition, the platoon provides couriers to supplement the battalion liaison officers.

1-12. SUPPORT PLATOON

The support platoon provides organic transportation, as well as Class I, Class III, and Class V resupply to the battalion. It is composed of a platoon headquarters, ammunition section, POL section, transportation section, and mess section. The platoon provides the majority of the battalion's combat service support.

1-13. MEDICAL PLATOON

The battalion medical platoon is responsible for providing treatment and evacuation of casualties.

1-14. MAINTENANCE PLATOON

The battalion maintenance platoon is structured to maintain, evacuate, and repair the vehicles in the battalion. It is organized into a platoon headquarters, an inspection and quality control section, a maintenance administrative section, a recovery support section, a maintenance/services section, and company maintenance teams.

1-15. COMBAT SUPPORT

In addition to the organic mortars, the task force commander will receive additional fire support from divisional and nondivisional

units. The commander must integrate and synchronize his supporting fire support elements to suppress and destroy the enemy in support of the maneuver plan. Synchronization also requires close coordination with adjacent units and Army aviation assets. Combat support assets normally available to the battalion task force are —

- Cannon field artillery.
- Close air support.
- Air defense artillery.
- Engineers.
- Military intelligence.

Section IV. BATTLEFIELD OPERATING SYSTEMS

1-16. OPERATING SYSTEMS

Task force functions are grouped into seven battlefield operating systems that must be integrated to support the commander's intent. The functioning of each system requires the coordinated efforts of all elements of the task force. The commander and staff integrate these systems into a combined arms force tailored to the situation.

a. Command and Control.

- (1) The commander fights from a forward location where he can best see, hear, and influence the battle. He issues the orders necessary to control his subordinate units. His subordinate commanders and his soldiers must be aware of his presence on the battlefield.
- (2) The task force uses standard military terminology, symbol-ogy, and reports and orders formats to distribute information and instructions. Face-to-face coordination is the most reliable of all means of communication. Copies of orders and instructions are limited and are generally in the form of operations overlays with superimposed execution matrixes. Wire is used as the preferred means of communications between elements that will be in position for more than a few hours. Radio communication is critical to fast-moving operations, but it has limitations and the enemy can disrupt it during critical times. Knowing the commander's intent and concept of the operations allows subordinates to act on their initiative and precludes an overdependence on radio communications.

- (3) The S3 is responsible for orders preparation and, through the task force signal officer, manages the electronic, wire, and messenger systems.
- b. **Maneuver.** The maneuver companies of the task force destroy enemy forces and seize and hold terrain. All other task force assets support the maneuver elements.
- (1) Historically, the infantry has been most effective during limited visibility, where observation and fields of fire were limited, and in close combat with the enemy. With the introduction of the improved TOW vehicle and Bradley fighting vehicle, the infantry has gained increased flexibility to destroy enemy armor at long range and to fight mounted, during limited visibility, while retaining the ability to fight dismounted as the situation requires.
 - (2) Tanks are most effective where they can move fast and provide rapid, accurate direct fire at extended ranges. Thermal sights increase the capability of tanks to fight during limited visibility.
 - (3) Attack helicopters are a maneuver asset that may operate with the battalion even though they are normally under OPCON of the brigade. They are highly mobile and can provide accurate long-range antitank fires during the defense, attack, exploitation, or pursuit. Attack helicopters can deny terrain to the enemy, but cannot seize and hold terrain, and they are not effective against a dug-in enemy.
- c. **Fire Support.** The task force commander plans and coordinates his fire support to suppress, neutralize, or destroy the enemy. The FSO assists the commander in planning and coordinating fire support. In addition to organic mortars, the commander receives fire support from field artillery units and close air support from the Air Force.
- (1) The mortar platoon provides organic indirect fires for the task force.
 - (2) Field artillery provides a variety of indirect fires to the task force. It can deliver smoke, scatterable mines (FASCAM), cannon-launched guided projectiles (Copperhead), antipersonnel and antimateriel munitions, and, when they have been released, chemical and nuclear munitions.
 - (3) US Air Force close air support (CAS) provides additional fires. Each battalion task force is augmented with a TACP from the US Air Force.

- d. **Intelligence.** All units have a responsibility to report information about the enemy. However, the task force has only the scout platoon and infantry patrols dedicated to gather information. Ground surveillance radar (GSR) may be attached from the divisional military intelligence battalion; electronic warfare units operate in support of higher headquarters. The brigade provides intelligence to the task force that is beyond the task force's capability to collect.
- e. **Air Defense.**
 - (1) The battalion task force has no organic, dedicated air defense weapons. Normally, the minimum air defense provided to the battalion is a Stinger section or a Vulcan platoon. However, the task force often must rely solely on passive air defense measures such as concealment, camouflage, and dispersion coupled with the use of small-arms, machine guns, and even main tank guns as its means of defense.
 - (2) Airspace command and control procedures are issued by corps and coordinated down to task force. These measures are used to synchronize the efforts of Air Force, Army aviation, indirect fire, and ADA. This allows the commander to simultaneously apply the combat power of all systems. The S3 air coordinates airspace command and control measures, and the S3 ensures that they complement the scheme of maneuver.
- f. **Mobility, Countermobility, and Survivability.**
 - (1) Engineers.
 - (a) All units can perform limited engineering tasks, such as digging two-man fighting positions and emplacing mines. Combat engineers provide additional mobility, countermobility, and survivability support to the task force. Engineers construct obstacles, emplace and clear minefield, prepare demolitions, improve roads, provide bridging, and dig fighting positions.
 - (b) Depending on the engineer support available, the brigade commander normally places at least an engineer platoon, and usually an engineer company, in support of the task force. The engineer unit leader advises the commander on the employment of his unit; the S3 ensures the obstacle plan supports the scheme of maneuver.
 - (2) Nuclear, Biological, and Chemical. Units must be able to operate under NBC conditions to survive and accomplish

their missions. This requires that units apply and adhere to the NBC defense fundamentals — contamination avoidance, NBC protection, NBC decontamination.

- (a) The task force has decontaminating apparatuses which provide it a hasty decontamination capability.
- (b) Additional support may be available from the division's chemical company that normally provides each maneuver brigade a decontamination platoon in direct support. NBC support is discussed in more detail in Chapter 6.

g. Combat Service Support.

- (1) CSS is those actions taken to sustain the task force's ability to fight. The sustainment functions in combat are: manning, arming, fueling, fixing, transporting, and protecting.
- (2) The S1, S4, HHC commander, maintenance officer, medical platoon leader, and support platoon leader, supervise CSS operations. The XO monitors CSS during all phases of operations.

1-17. HUMAN DIMENSION

Though not an operating system, a critical component of task force operations is a consideration of the *human dimension*. Battlefield tasks are accomplished by soldiers and not by "systems." The cohesion of units must be maintained to maximize the trust that soldiers have in their leaders and in their teams. Commanders must consider the training and experiences of personnel to develop plans that use units and key individuals in their best capacity. SOPs must be used, sleep plans and safety discipline must be enforced, and attention must be paid to noncombat details such as ensuring that combat power is sustained through routine, but critical support activities like serving hot rations. All leaders must ensure that every action possible is taken to enhance soldier morale, health, welfare, and overall readiness to fight.

Section V. SPECIAL OPERATIONAL ENVIRONMENTS

The battalion task force must be prepared to fight on any type of terrain and during adverse weather conditions.

1-18. URBAN AREA OPERATIONS

On the urbanized battlefield, the battalion uses the advantage of both natural and man-made features. Urban sprawl adds strength to a defense by providing covered and concealed positions and by restricting the attacker's mobility and observation. In restrictive urban terrain, dismounted forces are required to find the enemy and then fight the close-in battle. If a built-up area must be retained, a dismounted defense is organized in depth and supported by strong mobile forces. (See FM 90-10.)

1-19. DESERT OPERATIONS

Desert operations require special training, acclimatization, and a high degree of self-discipline. While the techniques of combat may vary from those used in a temperate climate, the principles and fundamentals of combat do not change. The task force commander must give special consideration to increased visibility, wide enemy mobility corridors, and the special problems associated with logistics support. The desert is especially hard on vehicles, and resupply is complicated by extended distances and increased maintenance problems. (See FM 90-3.)

1-20. JUNGLE OPERATIONS

The jungle environment slows heavy battalion movement and impedes military operations. Severe weather also adversely affects operations in the jungle. The degree to which soldiers are acclimated and are trained to live and fight in the jungle will contribute to a unit's success or failure. This environment is dominated by limited visibility. Problems of flank coordination, mutual and adjacent support, and enemy infiltration are greatly increased. (See FM 90-5.)

1-21. MOUNTAIN OPERATIONS

The mountain environment requires some modification of tactics and techniques. Not only do mountains themselves impose a serious barrier, but also the severity and variance of weather has a significant impact on military operations. Movement and fields of fire are restricted by the terrain, but mechanized vehicles may be used by dismounted troops to reduce the energy and time required to move by foot. (See FM 90-6.)

1-22. COLD WEATHER OPERATIONS

Cold weather conditions vary from those in central Europe to the extremes of the subarctic, and will affect battalion operations. Optical systems may be degraded by snow conditions thus reducing engagement ranges. Cold weather conditions can change the effectiveness of natural and reinforced barriers. (See FM 90-11.)

CHAPTER 2

COMMAND AND CONTROL

This chapter describes task force command and control principles, procedures, and techniques, and it outlines a system that allows the task force commander to apply the concepts of AirLand Battle doctrine and win.

CONTENTS		PAGE
PARAGRAPH		
Section I.	COMMAND AND CONTROL RESPONSIBILITIES	2-2
2-1	Organization	2-2
2-2	Responsibilities	2-2
Section II.	COMMAND AND CONTROL FACILITIES	2-7
2-3	Main Command Post	2-8
2-4	Tactical Command Post	2-8
2-5	Command Group	2-9
2-6	Combat Trains Command Post	2-9
2-7	Field Trains Command Post	2-9
Section III.	COMMAND AND CONTROL PROCESS	2-10
2-8	Planning	2-11
2-9	Factors of Mission, Enemy, Terrain (and Weather), Troops and Time Available	2-12
2-10	Decision-Making Process.	2-14
2-11	Troop-Leading Procedures	2-14
Section IV.	INTELLIGENCE PREPARATION OF THE BATTLEFIELD	2-22
2-12	Purpose	2-23
2-13	Functions of the IPB Process	2-23
Section V.	COMMAND AND CONTROL COMMUNICATIONS	2-29
2-14	Communications-Electronics Responsibilities	2-29
2-15	Radio Nets	2-30
2-16	Eavesdrop System	2-31
2-17	Mobile Subscriber Equipment	2-32
2-18	Communication Security and Anti jamming	2-32
Section VI.	OTHER COMMAND AND CONTROL PROCEDURES	2-33
2-19	Operations Security	2-33
2-20	Fire Control	2-34

Section I. COMMAND AND CONTROL RESPONSIBILITIES

Command and control is the process through which the activities of the task force are planned, directed, coordinated, and controlled to accomplish the mission. This process encompasses the personnel, equipment, communications, facilities, and procedures necessary to gather and analyze information, to plan, to issue instructions, and to supervise the execution of operations. The commander is responsible for command and control of organic, assigned, attached, and supporting forces, and for their synchronization into his operation.

Effective leadership is foremost among the elements of combat power that will decide victory. The leader must have a reliable, secure, fast, and durable command and control system. This system must communicate orders, coordinate support, and provide direction to the task force in spite of enemy interference and the loss of command facilities and key individuals.

The command and control system must be faster and more effective than the enemy's system. This allows the commander to receive and process information and to make and execute decisions faster than the enemy. The overriding goal of this system is to implement the commander's will in pursuit of an objective.

2-1. ORGANIZATION

The battalion commander determines the command and control organization that best supports his method of operations. He organizes his staff, determines the succession of command, and assigns responsibilities. The command and control organization is established by task force SOP. The typical task force command and control organization is shown in Figure 2-1.

2-2. RESPONSIBILITIES

The battalion staff is composed of personal, coordinating, and special staffs. The responsibilities of the members of the command and control organization are outlined below. The commander may modify these responsibilities based on the situation and individual capabilities.

- a. **Battalion Task Force Commander.** The commander commands all elements of the task force. He provides his subordinates with missions, taskings, and a clear statement of his intent. The

commander allows subordinates freedom of action in implementing his orders.

- b. **Executive Officer.** The XO is the principal assistant to the battalion commander. He is the battalion "chief of staff," and he is second in command. He is the principal integrator of CSS in support of maneuver. During the commander's absence, he represents the commander and directs action in accordance with established command policy and guidance. During the battle, he is normally in the main command post where he monitors the battle, reports to higher headquarters, keeps abreast of the situation at higher headquarters and units on the flanks, integrates CS and CSS into the overall plan, and plans for future operations. He is free to move to any point in the area of operations to accomplish his duties and responsibilities.

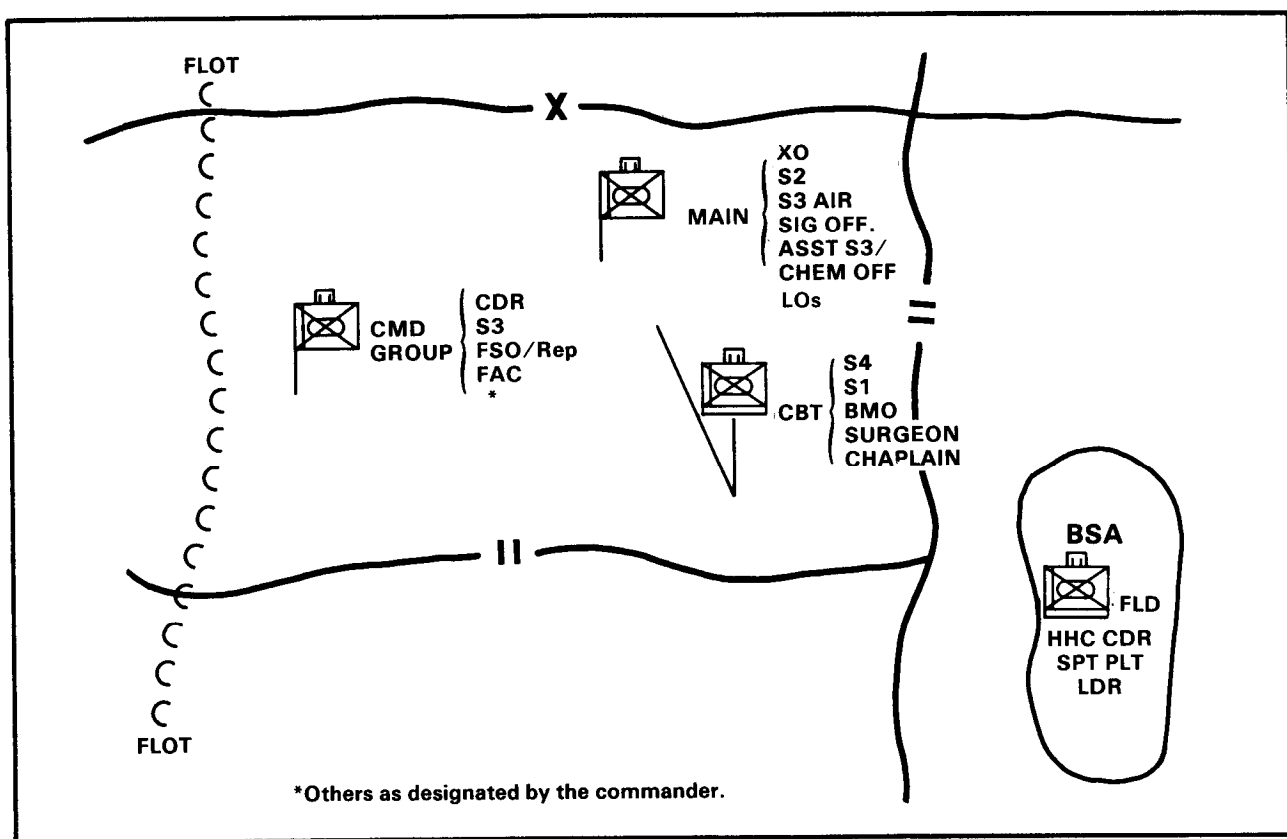

Figure 2-1. Command and control organization on the battlefield

- c. **Command Sergeant Major.** The command sergeant major (CSM) is on the commander's personal staff and is his primary advisor concerning enlisted soldiers. He must know the administrative, logistical, and operational functions of the battalion. Since he is the most experienced enlisted soldier in the battalion, his attention is focused on soldier and soldier support matters. The CSM may act as the commander's troubleshooter in supervising critical aspects of an operation. The CSM may also perform critical liaison, coordinate passage of lines, lead advance or quartering parties, supervise at key breach/ford sites, monitor key defensive preparations, assist in the CSS effort, and monitor unit morale.
- d. **Coordinating Staff.** The coordinating staff officers are the principal staff assistants to the commander.
 - (1) **S1 (adjutant).** The S1 is a principal staff officer with responsibility for exercising staff functions and coordination for personnel service support. Personnel service support encompasses the areas of personnel service, administrative services, health service support, finance support, postal services, chaplain activities, legal service support, morale, welfare support activities, and public affairs. The S1 is the assistant officer in charge of the combat trains CP, usually acting as a shift leader.
 - (2) **S2 (intelligence officer).** The S2 is responsible for combat intelligence. He organizes for continuous combat operations in coordination with the S3. The S2 coordinates input from the other staff officers. During operations, he updates the IPB and prepares and monitors reconnaissance and surveillance plans in conjunction with the S3. He provides staff supervision over supporting intelligence organizations and requests additional support from brigade to support the commander's intelligence requirements. He normally performs his duties in the main CP.
 - (3) **S3 (operations and training officer).** The S3 is responsible for planning, organizing the force and coordinating combat operations of the battalion and attached/OPCON units, and for coordinating with combat support units. He coordinates with the S2, FSO, and other combat support planners in preparing the task force order. He is responsible for integrating combat support (engineer operations, ADA, indirect fires, CAS, EW, Army aviation, and C³CM) into task force operations. He assists the commander in fighting the ongoing battle. The S3 operates forward with the commander.

- (4) **S4 (logistics officer).** The S4 is responsible for all battalion logistical activities. He supervises all organic and nonorganic logistical elements supporting the task force. He is responsible for the formulation of logistical policy. He plans, coordinates, and supervises the logistical effort, to include coordinating all aspects of CSS in paragraph 4 of the task force order with the S1 and the BMO. The S4 is responsible for the arrangement, security, and movement of the combat trains, and is the OIC of the combat trains CP.
 - (5) **Battalion maintenance officer.** The BMO plans, coordinates, and supervises the maintenance and recovery efforts of the maintenance platoon and ensures that adequate maintenance support is provided to the task force. Although a staff officer in the battalion headquarters, he is also the maintenance platoon leader. The maintenance warrant officer assists the BMO by providing technical assistance and supervision of the maintenance platoon. The BMO supervises the unit maintenance collection point (UMCP).
- e. **Special Staff.** Special staff officers assist the commander in command and control in special areas of expertise, generally under the direct supervision of a member of the coordinating staff.
- (1) **S3 Air.** The S3 Air is the principal assistant to the S3. As the battalion link to the Army airspace command and control system, he coordinates use of battalion airspace and the employment of air support with the FSO (FSCoord), the tactical air control party (TACP), and the aviation liaison officer, as well as the air defense section or platoon leader. The S3 Air works in the main CP.
 - (2) **Assistant S3/chemical officer.** The chemical officer is responsible for advising the commander on impacts of NBC employment on current or future operations. He coordinates and plans decontamination and smoke operations. He is located at the main CP.
 - (3) **Tactical intelligence officer.** The tactical intelligence officer works under the supervision of the S2 and is part of the two-man battlefield information control center (BICC). The BICC's primary responsibility is to perform unit intelligence collection, processing, and disseminating actions as tasked by the S2. The BICC operates in the main CP.
 - (4) **Liaison officers.** LOs are commissioned and noncommissioned officers who represent their commander at other headquarters. Through personal contact, they promote

cooperation and coordination, and facilitate the exchange of information. LOs are tasked with general coordination instructions in the task force SOP and with specific coordination instructions each time they are dispatched to another headquarters. Their role as task force commander representative requires LOs to know all task force plans and dispositions. LOs ensure that critical information is passed between the task force headquarters and the headquarters to which they are dispatched. When operating in the main CP, LOs are supervised by the shift OIC.

- (5) **Battalion signal officer.** The battalion signal officer, in addition to leading the communications platoon, exercises technical supervision over the installation and use of communication systems and the activities of communications personnel. His specific duties are directed by the battalion S3. He reconnoiters possible CP sites for communications capabilities; recommends retransmission equipment employment; establishes messenger services and schedules; and monitors COMSEC.
 - (6) **Battalion surgeon.** The battalion surgeon is the medical platoon leader. With the aid of a physician's assistant, he operates the battalion aid station in the combat trains. He and his assistant provide training for the medical platoon, treatment of the wounded, and information on the health of the battalion to the commander. A medical service corps officer and the platoon sergeant assist in the administration and the logistics of the medical platoon, and plan and coordinate patient evacuation to the supporting medical company.
 - (7) **Battalion chaplain.** The battalion chaplain provides religious services and personal counseling. As a special staff officer, he provides the commander with an in-depth view of the esprit de corps, spiritual well-being, and morale of the unit. Although he has a personal staff relationship with the commander, he coordinates his special staff actions through the S1, and operates from the combat trains.
- f. **Other Staff Assets.** The HHC commander, the task force FSO, the task force FAC, and the senior leaders of elements supporting the task force provide special staff assistance to the commander directly or through the primary staff.
- (1) **Headquarters and headquarters company commander.** The HHC commander is located in the task force field trains. He is responsible for coordination, security, and movement

of the field trains, both organic and attached. The HHC commander acts as a battalion task force CSS coordinator, assisting the S1 and S4 by ensuring that field trains support is smooth, timely, and efficient.

- (2) **Fire support officer.** The FSO is a habitually associated officer from the FA battalion in direct support of the brigade. He coordinates all fire support for battalion task force operations and as such, the battalion FSO is also the battalion FSCoord. The FSO establishes the fire support element at the main CP. The FSO monitors the positioning of the battalion mortar platoon and employs its fires. He also recommends the employment of any supporting field artillery assets. The FSO operates either from the main CP or forward with the commander.
- (3) **Forward air controller.** The FAC is a US Air Force officer responsible for coordination and employment of US Air Force assets in support of the task force. He is responsible for the tactical air control party as described in Chapter 7. He will primarily operate forward with the commander.
- (4) **Air defense artillery officer.** The senior leader of any supporting ADA unit(s) advises the commander on employment of ADA assets. During the planning process, he is at the main CP to ensure the integration of air defense into the concept of operation. During the execution of the plan, he positions himself to best command and control the air defense assets. He monitors the command net to remain responsive to the needs of the commander. He also monitors the early warning net to assist in the acquisition and dissemination of early warning information as a member of the Army airspace command and control system.
- (5) **Engineer.** The senior leader of any supporting engineer unit(s) also acts as a special staff officer advising the commander on employment of engineer assets. The task force engineer monitors the task force command net while directly supervising his unit during its operations.

Section II. COMMAND AND CONTROL FACILITIES

The task force command and control facilities consist of the vehicles and locations from which the task force commander, assisted by his staff, directs the battle and sustains the force. The exercise of command and control is focused in four major facilities — the main CP, the tactical CP, the combat trains CP, and the field trains CP.

2-3. MAIN COMMAND POST

The task force main CP is the control, coordination and communications center for combat operations. The main CP is composed of the S2 and S3 sections, the FSE, representatives from other attached elements, and the tactical CP (when not forward). The main CP vehicles and personnel must be as few as possible to allow for rapid displacement, but large enough to accomplish command and control functions in support of the commander.

- a. **Functions.** The functions of the main CP are to monitor and assist in command and control by maintaining contact and coordination with higher and adjacent units, continuously updating the enemy situation, planning operations, analyzing and disseminating tactical information, maintaining situation maps, and requesting and synchronizing additional CS and CSS for the battle. Factors that have immediate operational impact must be monitored by the main CP and communicated to the commander.
- b. **Operations.** The primary considerations in positioning the main CP are communications, accessibility, and survivability. The personnel who operate the main CP must be organized to provide both security and continuous operations on a 24-hour-a-day basis. A sleep plan must be enforced to preserve the ability of main CP personnel to perform continuous operations. The main CP internal SOP establishes this internal organization. Coordination between the main CP, the combat trains CP, and the field trains CP must be continuous to ensure that CSS is integrated into the mission effort. One technique is to monitor the administrative/logistics (A/L) net on a remote. When possible, a landline link is established with the combat trains CP. The security of the main CP is enhanced by its capability to displace rapidly and provide a reduced electronic signature. Displacements are planned to ensure the main CP is stationary during critical phases of the battle.
- c. **Alternate Main CP.** The combat trains CP is normally designated as the alternate main CP. (Aid station and UMCP assets may be collocated to enhance communications capability.) A mortar FDC track may also be used as an alternate main CP. If required to function as the main CP, the primary functions of these elements will suffer, and the effectiveness of the new main CP will also be degraded.

2-4. TACTICAL COMMAND POST

A tactical CP may be formed during fast-moving offensive or retrograde operations to maintain communications and facilitate the

movement of the main CP. In such circumstances the commander may designate one of the command post vehicles from the main CP to act as the tactical CP. Some or all of the command group may locate at the tactical CP at various times.

2-5. COMMAND GROUP

The command group consists of the commander and those he selects to go forward to assist him in controlling maneuver and fires during the battle. It normally includes the FSO, FAC, and S3. There is no requirement for these people to collocate; for example, the commander may be in one part of the battalion sector while the S3 might be in a separate part of the sector. The composition, nature, and tasks of the command group are determined by the commander to permit the optimum command and control of his unit during the battle.

2-6. COMBAT TRAINS COMMAND POST

- a. The combat trains CP is the coordination center for combat service support for the task force and the control element of the combat trains. It is positioned forward of the field trains. The S4 is responsible for operations, movement, and security of the combat trains, assisted by the S1. The S4, S1, and BMO must continually assess the situation, anticipate the needs of units, and prepare to push support forward. Anticipating requirements is the key to successful combat service support.
- b. The combat trains CP maintains the CSS status of the battalion. In preparation to assume its functions as alternate main CP, the combat trains CP monitors the task force command net and maintains charts and tactical situation maps identical to those at the main CP. The combat trains CP routinely operates a switchboard for elements in the combat trains and is the NCS for the battalion A/L net and operates in the brigade A/L net.
- c. Any change in the main effort of the battalion should be reported to the combat trains CP by the main CP or tactical CP. Similarly, a major change in the ability of the CSS system to support an operation must be immediately reported to the main CP by the combat trains CP. The combat trains CP relays information to the field trains CP.

2-7. FIELD TRAINS COMMAND POST

The field trains are under the control of the HHC commander whose headquarters is the field trains CP. When the TF commander collocates his field trains with the BSA, the HHC commander

coordinates with the forward support battalion for positioning and a defensive sector for the battalion field trains elements. When the task force commander deems it necessary, the field trains may be positioned outside of the BSA in the task force area of operations; in this case, the task force S3 designates the general location for the field trains or directs that unit trains be formed under the control of the S4.

- a. The field train CP is composed of the HHC commander, and the remaining elements of the S1 and S4 sections. It coordinates the collection and movement of CSS from the task force field trains and the forward support battalion, to forward elements of the task force. It controls and coordinates the activities of the task force field trains including operations of the support platoon, elements of the maintenance platoon in the field trains, company and attached units' supply sections, and the PAC. The field trains CP monitors the task force A/L net and maintains a communications link with the forward support battalion CP.
- b. Supplies, personnel, and mail going forward from the field trains are grouped together into logistics packages (LOGPACs) under the control of the support platoon leader or a company supply sergeant. The field trains CP organizes and dispatches LOGPACs based on instruction from the combat trains CP. (Chapter 7 contains detailed discussion of field trains operations.)
- c. The battalion trains are normally echeloned with both a combat trains CP and a field trains CP. The alternative configuration is to form unit trains with a single rear CP which is operated by the S4. In this case there is no field trains CP.

Section III. COMMAND AND CONTROL PROCESS

The task force command and control process involves planning, coordinating, and executing combat operations. While higher level headquarters give broad missions and allocate assets to fight the close and deep battle, task forces directly control and synchronize the actions of company teams, supporting fires and obstacles on the ground and against the enemy. Key command and control considerations for the battalion/task force commander include —

- Making maximum use of time.
- Conducting physical reconnaissance.
- Planning for and maintaining flexibility.

- Instilling and requiring initiative from all leaders.
- Decentralizing execution.
- Providing clear, concise missions.
- Synchronizing all assets.
- Designating and sustaining main effort.

2-8. PLANNING

Plans are the initial basis for action, but commanders must expect considerable variance from plans because the situation will change rapidly. After an initial order, task forces are usually directed by a series of FRAGOs with the commander continually making decisions to fight the battle.

- a. In planning an operation, the task force commander focuses on developing a concept of the operation that best accomplishes the task force's mission and the brigade's and division's intent. He assigns missions and tasks to subordinate elements and allocates forces and establishes priorities to make the concept work.
- b. Planning must be rapid to give adequate time for preparation, coordination, and planning. Planning is continuous. Initial plans are updated and refined but complete change is avoided especially if it negates subordinate planning and preparation.
- c. Plans must be simple to understand and prevent undue difficulty in execution. While conciseness is required in plans, there must be sufficient elaboration for understanding and coordination.
- d. Standing operating procedures that are detailed, understood, and practiced allow for short concise plans. Orders do not repeat SOP items understood by all subordinates.
- e. Routinely, the task force will have limited time to plan and prepare to conduct an operation, such as when receiving an immediate mission while acting as a reserve or conducting a movement to contact. During such situations, the troop-leading procedures are the basis for planning and preparation. The commander does a rapid estimate with the other members of the tactical CP. A quick radio update is provided by subordinates, and the commander and staff pass other information needs to the main CP over radio. The commander gathers his leaders to quickly explain the concept, visually show the concept on a map, hand out a few control graphics, and allow face-to-face coordination. A FRAGO sent over the radio is far less desirable but sometimes required.

2-9. FACTORS OF MISSION, ENEMY, TERRAIN (AND WEATHER), TROOPS AND TIME AVAILABLE

The factors of METT-T are considered during the development of all estimates, including IPB. Each factor must be evaluated in conjunction with the other factors in order to gain a true appreciation of the battlefield. A significant change in one or more of the factors of METT-T will usually cause change in the OPLAN or OPORD.

- a. **Mission.** The primary task assigned to the unit is its mission. The task force mission is given in the brigade OPORD or FRAGO. It contains key requirements in terms of who, what, when, where, and why. The commander conducts a detailed mission analysis to determine the role of the task force in the higher commander's operation, and the specified and implied tasks necessary for mission accomplishment. The "why" in the mission statement is the basis of the task force commander's intent for the operation. He develops his intent in terms of overall effect on the enemy, resulting task force positioning, and any activities that are otherwise critical to accomplish his higher commander's plan.
- b. **Enemy.**
 - (1) Enemy forces are evaluated to determine their capabilities, likely courses of action, and impact on task force courses of action. At the start of hostilities, or when the task force is assigned a new area of operations, information on the enemy force is initially provided by higher headquarters. Later, the task force may have first-hand information on the enemy, but will still require information from higher headquarters on enemy flank and second echelon forces.
 - (2) IPB includes a detailed analysis of the enemy and provides the commander with templates of likely enemy positions and enemy ground and air avenues of approach, as well as other information. The S2 begins the IPB process. In conjunction with the S3 and the commander, he develops probable time guidelines, templates of enemy positions or formations, named areas of interest (NAIs) and target areas of interest (TAIs). NAIs are areas that will most likely give indicators of enemy intentions; TAIs are areas to be attacked that will most likely have a damaging effect on enemy forces or plans.
 - (3) The task force uses its scouts, infantry patrols, and any supporting ground surveillance radars to verify enemy information. Additionally, maneuver companies' reports, calls for fire monitored by the fire support element (FSE),

and adjacent unit reports are reviewed to verify information and to disclose the enemy's intent.

c. Terrain (and Weather).

- (1) **Terrain.** Terrain analysis is the process of examining the military aspects of terrain and their effects on friendly and enemy capabilities to move, shoot, and communicate. The military aspects of terrain include the following five factors (OCOKA): Observation and fields of fire, Cover and concealment, Obstacles and movement, Key terrain, and Avenues of approach. The military aspects of terrain at battalion-level are considered in terms of platoon positions and actions.
- (2) **Weather.** Weather affects equipment, terrain (trafficability), visibility, and soldiers. Generally, adverse weather favors the attacker, even though mobility and command and control are degraded. Task force plans and orders must accommodate adverse weather (including the effects of smoke) and take advantage of them.

d. Troops. The commander evaluates troop strength and combat status in terms of the seven battlefield operating systems and human dimension factors such as fatigue, training, morale, and leadership. Maneuver companies, fire support, and engineer assets are initially the key elements considered.

e. Time Available.

- (1) Time is the critical factor in all operations. The commander gets his first indication of time available from the higher headquarters order. Specific considerations of time (and timing) include —
 - Coordination and planning time.
 - Time operation is to commence, and therefore the time available for preparation and reconnaissance.
 - Movement times from present positions to sectors, battle positions, or lines of departure.
- (2) Other timing considerations are considered during the wargaming process and include —
 - Rate of closure of a moving enemy force.
 - Movement times during the operation (moving from one battle position to another; time from one phase line to the next).

- Timing and duration of preparation fires or smoke.
- Time to complete specific actions during the operation.

2-10. DECISION-MAKING PROCESS

- a. Task force commanders manage time by ensuring that the leadership executes the troop-leading procedures and decision-making process simultaneously. The troop-leading procedures and decision-making process are complementary actions that continue in an uninterrupted manner from operation to operation.
- b. The decision-making process is as detailed — or as simple — as time allows. The commander plays the central role in this process, with the staff providing advice and information related to their respective areas (see Figure 2-2). The commander's decisions are based on his analysis of the factors of METT-T, staff input, information gained through reconnaissance, analysis and comparisons of feasible courses of action, wargaming, and his personal judgment. The decision-making process must be able to accommodate rapid changes on the battlefield. A detailed explanation of the formal decision-making process is in FM 101-5.

2-11. TROOP-LEADING PROCEDURES

- a. The following describes the task force command and control process — analysis of METT-T; estimate of the situation; decision-making; and troop-leading procedures. It applies to all types of tactical operations. Specific tactical considerations for the various types of task force missions are in appropriate chapters of this manual. **The troop-leading procedures can occur in almost any sequence, with several actions taking place simultaneously. Some actions, such as reconnoiter, may begin early and be repeated as often as required.** Figure 2-3 (page 2-16) shows the relationship of the factors of METT-T, the estimate of the situation, and the troop-leading procedures.
- b. Troop-leading procedures begin with an assigned or perceived mission and end with mission accomplishment.
 - (1) **Receive the mission.**
 - (a) On receipt of the mission, the task force commander and his staff exchange information and conduct a preliminary METT-T analysis. The initial analysis determines —
 - What is the mission (task and purpose)?

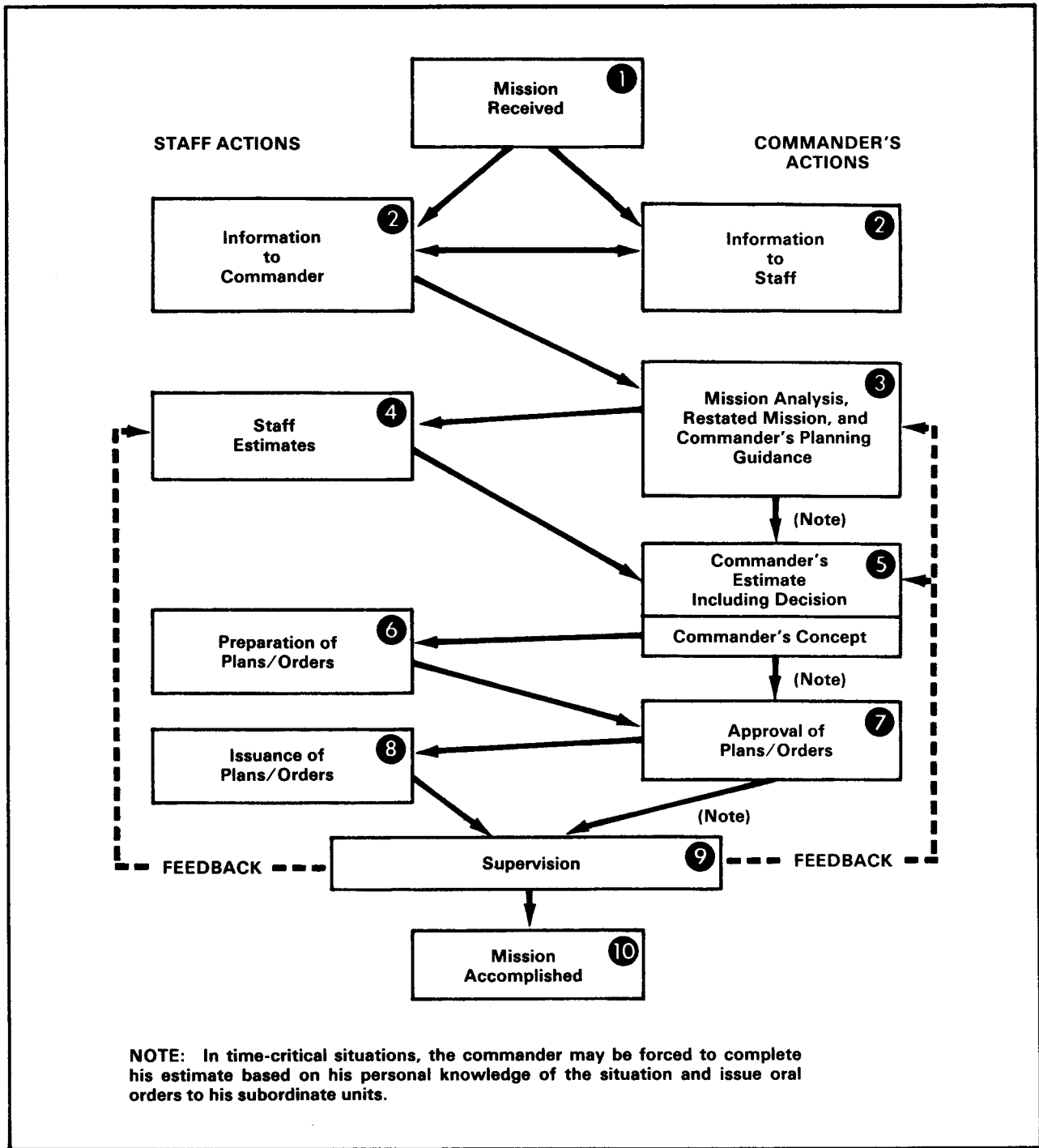

Figure 2-2. Military decision-making process.

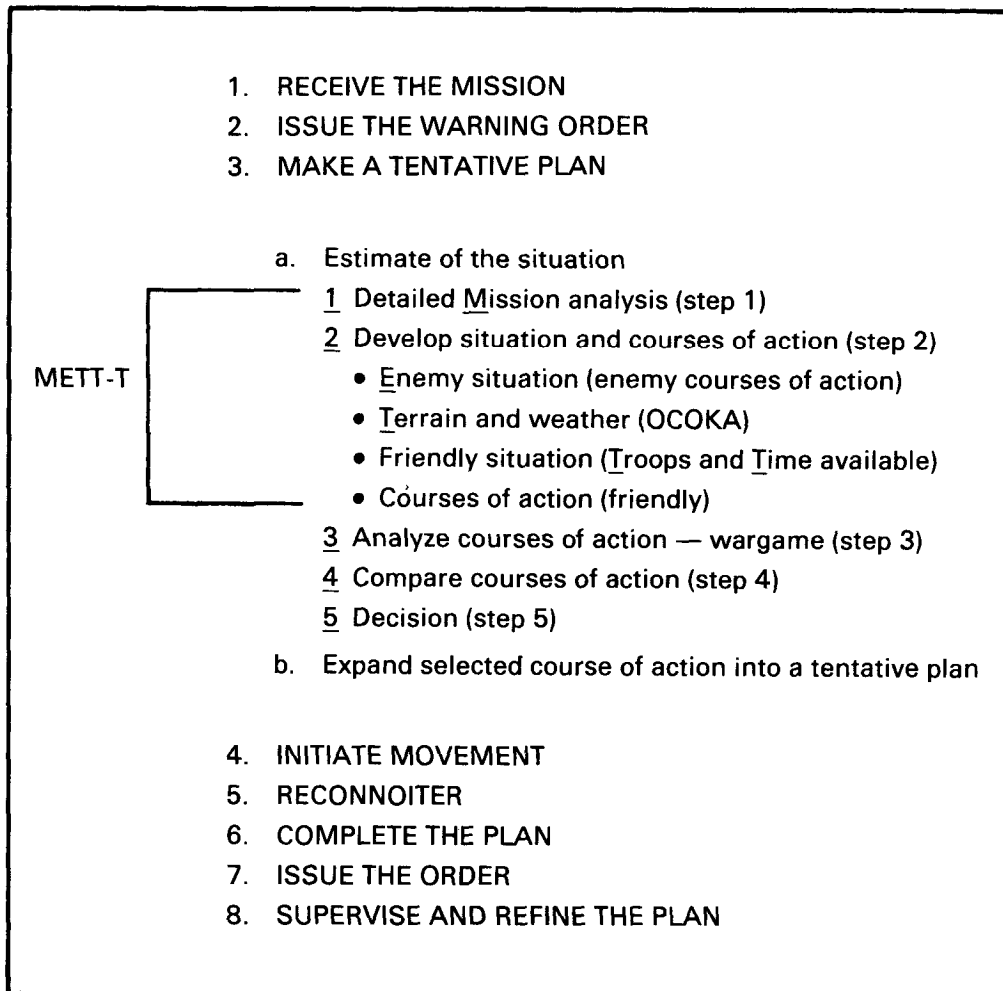

Figure 2-3. METT-T, estimate of the situation, and troop-leading procedures.

- Who is the enemy (unit, size, type)?
- Where is the area of operations (is movement required; when must it start)?
- Attachments and detachments (who, when)?
- Time available (time for further planning, when to issue the warning order, FRAGO, or OPORD)?

(b) The commander and staff make an informal schedule to ensure that no more than one-third of the available

time is used to prepare and issue the FRAGO or OPORD. The commander makes rapid deductions and issues instructions to his staff, who issue a warning order. The commander should disseminate as much preliminary information as possible to his subordinates so that they may begin their troop-leading procedures. He also determines what critical information he needs from his staff, higher headquarters, and reconnaissance to continue the planning process. The scouts are almost always ordered to move immediately to an area and begin a reconnaissance. Leader reconnaissance begins as soon as feasible and is as detailed as time permits.

- (2) **Issue the warning order.** A warning order is issued immediately on receipt of an order or warning order from brigade. The warning order informs the staff and subordinate commanders what the operation is, when it is scheduled to commence, what preliminary actions are required, and where and when the order will be issued. Detailed discussions of warning orders and examples are in Appendix B.
- (3) **Make a tentative plan.** The task force commander, assisted by the staff, begins his estimate process:
 - (a) **Estimate of the situation.** The estimate of the situation is an integral part of task force decision-making. The estimate of the situation incorporates analysis of the factors of METT-T and analysis of friendly courses of action into a process that allows the commander to select the best course of action as the basis for the task force plan. At the task force level, the estimate is a mental process. (See FM 101-5, Chapter 5, for a full discussion of command and staff estimates of the situation.)

Step 1. Detailed mission analysis. The brigade order is reviewed to determine all specified and implied taskings. The mission-essential tasks are incorporated into the task force commander's restated mission. The commander gives the staff the restated mission and guidance, including the constraints and implied tasks identified during the mission analysis.

Step 2. Develop situation and courses of action. Based on the restated mission and commander's guidance, the staff begins planning for the new operation. The task force staff assists by providing updated staff estimates, or, more likely, by providing

requested facts and recommendations. Critical information provided includes the S2's initial situation template, the combat status of the task force, the availability of support, and recommendations concerning preparations. As early as possible, the task force commander provides his intent, which is his visualization of how the enemy is to be defeated and of the battlefield after the mission is accomplished. The commander's intent is a clear statement of the desired effects of the task force's operation. It must expand on the "why" of the mission statement to explain the "big picture." It is a statement of purpose or intended outcome, rather than guidance about how to conduct the operation. The commander and the S3 then develop tentative courses of action:

- For offensive missions, considerations include subordinate unit objectives, how the task force will move along the avenues of approach, the form of maneuver used against the enemy, designation of the main attack, supporting attack, and reserve forces, as well as other considerations to accomplish the mission.
- For defensive operations, considerations include as a minimum, determining where the enemy will be defeated, positioning of forces along the avenues of approach, either in depth or at critical areas, and designation of counterattack forces and reserves.
- The internal task organization of the task force is considered along with each course of action. Task organization is the primary method the task force commander uses to ensure that companies have the combat power they need to accomplish their assigned missions.

Step 3. Analyze courses of action — wargame.

- One technique to evaluate courses of action is to wargame them against likely enemy courses of action, beginning with the most probable. At task force level, wargaming is a mental process of visualizing each step of the battle, considering task force actions, enemy reactions, and task force counteractions.
- IPB plays an important part in wargaming the courses of action. Through IPB, the commander

and S2 develop a clear picture of the battlefield, the courses of action available to the enemy commander, enemy actions that disclose which course of action the enemy will adopt (indicators), and to establish decision points or lines that are used to specify points during friendly or enemy movement that require task force action. When a decision point is reached, the task force (or supporting assets or individual teams) takes a specified action, such as counterattack, fire a group of targets, or displacing to a supplementary position. The specified actions are taken either automatically or on order as directed by the OPORD. Wargaming often involves the entire staff in planning the use of combat support assets, to include establishing priorities, command and support relationships, assigning targets, and fixing responsibilities.

Step 4. Compare courses of action. The analysis of the courses of action identifies advantages and disadvantages of each. These are compared by the commander and staff. If time and situation permit, each staff officer briefs his area of responsibility concerning each course of action. If this is not possible, the commander must rapidly consider all available information. Based on the staff recommendations and his own knowledge and experience, the commander decides on a course of action and expands the selected course of action into the concept of the operation.

Step 5. Decision. Based on the comparison of courses of action, the task force commander chooses or modifies one and gives his decision to the staff in the form of a concept of operation. Necessary orders are issued, and the S3 or XO supervises compilation of the complete plan or order. The commander and S3 then initiate movement as necessary and conduct a reconnaissance to obtain information to finalize the plan.

- (4) **Initiate movement.** Based on the tentative plan, movement of the elements of the task force or preparations begin. Some movement or preparation, especially scout reconnaissance, may have been directed immediately on receipt of the warning order. Additional warning orders, FRAGOs, or movement instructions are issued as the plan is developed.

(5) **Reconnoiter.**

- (a) Task force leaders routinely reconnoiter the terrain. The reconnaissance is as extensive and detailed as possible. The task force commander may assign certain reconnaissance tasks to each of his subordinates. Normally, each company team commander is assigned his tentative areas of responsibility; however, they may also be assigned to reconnoiter other areas, such as the flanks, rear, or routes. Leaders and the staff reassemble at a prearranged time and location to report on their efforts. The information gathered by the leaders as well as information from other sources (for example, scouts and patrols) is used to complete the plan.
- (b) One technique to expedite the reconnaissance effort and planning is to establish orders groups, who assemble on order of the commander. For example:
- Orders Group **Alpha** (for hasty planning or reconnaissance): task force commander, XO, S3, S2, FSO.
 - Orders Group **Bravo** (for detailed planning): Orders Group Alpha, S1, S4, FAC, engineer, air defense officer, scout platoon leader, mortar platoon leader, GSR section leader, BMO, CSM, CESO, S3 Air, chemical officer, Company E commander.
 - Orders Group **Charlie** (for hasty reconnaissance or hasty issuance of orders): Orders Group Alpha, company and team commanders and FSOs, scout platoon leader.
 - Orders Group **Delta** (for detailed issuance of orders): All orders groups, LOs.

(6) **Complete the plan.**

- (a) Using the latest reconnaissance and intelligence information, the commander's concept of the operation is finalized, details are added, and the order is prepared. Actions are taken to compensate for any disadvantage associated with the chosen course of action and contingency plans are fully developed. The final task organization, plans for fire control, CSS, security, surveillance, communication, additional command and control measures, and lateral or flank coordination are refined and incorporated into an OPORD. Requirements for additional support are determined and requested from higher headquarters. Coordination with adjacent, supporting, and higher headquarters is made.

- (b) An order consisting of at least an overlay with graphics and an execution matrix may be used in fast-moving situations. The one-third — two-thirds rule should be adhered to, whereby the higher echelon headquarters only uses one-third of the planning time available, including the time it takes to issue the order.

(7) Issue the order.

- (a) If possible, the order is issued from a vantage point overlooking the terrain on which the operation will be conducted. If not possible, the commander should use any aids he can to assist personnel to visualize the terrain such as a sketch or a sand table.
- (b) One technique is to require subordinates to backbrief the commander on their units' role to ensure they understand their instructions and the commander's intent. This can be done following the orders briefing, or, preferably, at some later time before the subordinate commander's operation order. Ideally, backbriefs are conducted while overlooking the terrain with all commanders, FSOs, and key staff present.

(8) Supervise and refine the plan.

- (a) The commander and his staff supervise the preparations for the operation. These preparations include coordination, reorganization, fire support, engineer activities, maintenance, resupply, and movement. Any departure from the plan, both before and during the operation, is coordinated with the task force commander. As subordinate commanders develop their plans and begin detailed preparations and reconnaissance, minor changes may be necessary to implement the commander's intent. For example, if the commander responsible for a planned obstacle determines that he cannot cover it with fire, he has it emplaced where it can be covered by fire and best support his plan. This changed location must be coordinated with the FSO and the main CP.
- (b) Rehearsals are conducted to reinforce both the scheme of maneuver and the fire plan. Whenever possible, rehearsals are conducted under limited visibility or NBC conditions and over similar terrain. Key staff and subordinate commanders participate in rehearsals to identify problem areas and contingency actions, determine movement and reaction times, enhance

coordination, and refine the plan. Ideally, rehearsals and briefbacks identify key events and critical tasks which subordinates must address to the commander's satisfaction.

- (c) Whenever a significant change in the factors of METT-T occurs, the main CP must ensure that the task force commander, staff, and subordinate unit commanders are notified. Before the start time of the operation, the S2 should update any changes to the known enemy situation.
- (d) Lateral communications between company team commanders, the scouts, and the task force commander are critical to command and control. Company commanders must talk to each other during the battle. Each commander must tell the commanders on his flank or to his rear what he is planning to do, and make appropriate recommendations to other company team commanders and to the task force commander.
- (e) Refinement of the plan is a continual process that does not stop at the beginning of the operation. Throughout the fight, the commander concentrates on monitoring the progress of the battle, but he does not hesitate to adjust or modify his original plan when the development of the battle or a significant change in the factors of METT-T requires it.

Section IV. INTELLIGENCE PREPARATION OF THE BATTLEFIELD

Intelligence preparation of the battlefield is an integral part of the battalion command and control process. It is the primary factor that will allow the battalion to react quicker than the enemy. The S2 is responsible for collecting, analyzing, and reporting information concerning weather, enemy, and terrain. The analyzed information is then disseminated as intelligence. IPB is continuous, and it provides a basis for all intelligence operations, tactical decisions, and tactical operations. The staff uses IPB information in developing the operation plan, the collection plan, and the reconnaissance and surveillance plan. This section provides information on how the battalion S2 conducts IPB and then applies it to the development of the tactical plan.

2-12. PURPOSE

- a. IPB is the continuous process of analyzing the weather, enemy, and terrain for a specific battlefield area for all tactical operations. It integrates threat doctrine with the terrain and weather to determine and evaluate enemy capabilities, vulnerabilities, and probable courses of action.
- b. The task force S2 relies on higher headquarters to provide much terrain and weather information. The formal IPB process is performed at corps and division and the informal IPB process is performed at brigade/battalion levels.

2-13. FUNCTIONS OF THE IPB PROCESS

The functions of the IPB process are battlefield area evaluation, terrain analysis, weather analysis, threat evaluation, and threat integration.

a. Function 1 — Battlefield Area Evaluation.

- (1) During Function 1 of IPB, the scope is narrowed to the battalion task force present and future area of operations and interest. The commander and S2 view each of these areas in four dimensions: width, depth, height, and time.
- (2) After the specific areas have been defined, the S2 assembles the information and materials required to continue the IPB process. Normal climatic, weather, and area studies also should be acquired from the G2. Map requirements include complete coverage of areas of operations and areas of interest. Standard military topographic maps are used.

b. Function 2 — Terrain Analysis.

- (1) Function 2 of the IPB process, terrain analysis, identifies the effects of terrain on combat operations and is performed concurrently with Function 3, weather analysis.
- (2) The S2 relies on higher headquarters to provide terrain factor overlays and other detailed terrain products to perform IPB. In the absence of such overlays, he conducts the analysis with assistance from the task force engineer. Listed below are terrain factor overlays normally available to the battalion task force.
 - Vegetation.
 - Surface materials (soils).

- Surface drainage.
 - Slope.
 - Obstacles.
 - Transportation (roads and bridges).
 - Cross-country movement (wet and dry).
 - Concealment (summer and winter).
 - Groundwater (planning data base only).
- (3) Terrain is analyzed using the five military aspects of terrain (OCOKA) detailed below.
- (a) Observation and fields of fire. Observation is the ability to see over a particular area. Fields of fire refer to the area a weapon can cover effectively from a given point.
 - (b) Cover and concealment. Cover is protection from the effects of fire, concealment is protection from observation.
 - (c) Obstacles. Obstacles are existing or reinforcing features that stop, impede, or divert movement.
 - (d) Key terrain. Key terrain is any feature or area whose seizure or control offers a major tactical advantage.
 - (e) Avenues of approach. Avenues of approach are routes by which a friendly or enemy force may reach an objective or key terrain feature. The S2 should consider both ground and air avenues of approach. Mounted and dismounted avenues of approach include mobility corridors. Mobility corridors are areas within the avenues of approach that permit movement and maneuver. An avenue of approach is broad enough to contain sufficient mobility corridors to support rapid movement and maneuver of forces along its course. Avenues of approach are readily identified when NO-GO and SLOW-GO terrain has been depicted on a combined obstacle overlay. Once identified, avenues of approach should be analyzed (using OCOKA, ease of movement, and maneuver room) and then compared from both friendly and enemy perspectives. This comparison will help in identifying key and decisive terrain.

c. Function 3 — Weather Analysis.

- (1) Weather is critical to battalion tactical operations. Reliance on mobility requirements for ground operations may be

affected significantly by prevailing weather conditions. The five military aspects of the weather that concern intelligence support to operation planning are: temperature and humidity, precipitation, winds, clouds, and visibility.

- (2) The S2 relies heavily on the staff weather officer and weather team at division to provide specific weather subfactor information including —
 - Ground fog.
 - Severe weather.
 - Cloud-free line-of-sight (CLOS).
 - Terrain influenced wind direction (TIWD).
 - Snow depth.
 - Ice thickness.
- (3) The S2 then integrates weather data with terrain data. The S2 combines his own hasty analysis with available intelligence products, such as short- and long-range forecasts, light data tables, and climatic summaries when analyzing terrain.

d. Function 4 — Threat Evaluation.

- (1) The S2's IPB threat evaluation consists of a study of available enemy order of battle (OB) factors. These include —
 - Unit identification.
 - Composition.
 - Disposition.
 - Strength.
 - Training.
 - Tactics.
 - Logistics.
 - Combat effectiveness.
- (2) When such detailed OB data is not available, the primary threat evaluation tool is a generic doctrinal template (see Figure 2-4, page 2-26). A doctrinal template depicts the enemy doctrinal deployment for various types of operation without the constraints imposed by weather and terrain. Specifically, composition, formation, frontages, and depths are displayed.
- (3) During threat evaluation, the S2 identifies high value targets.

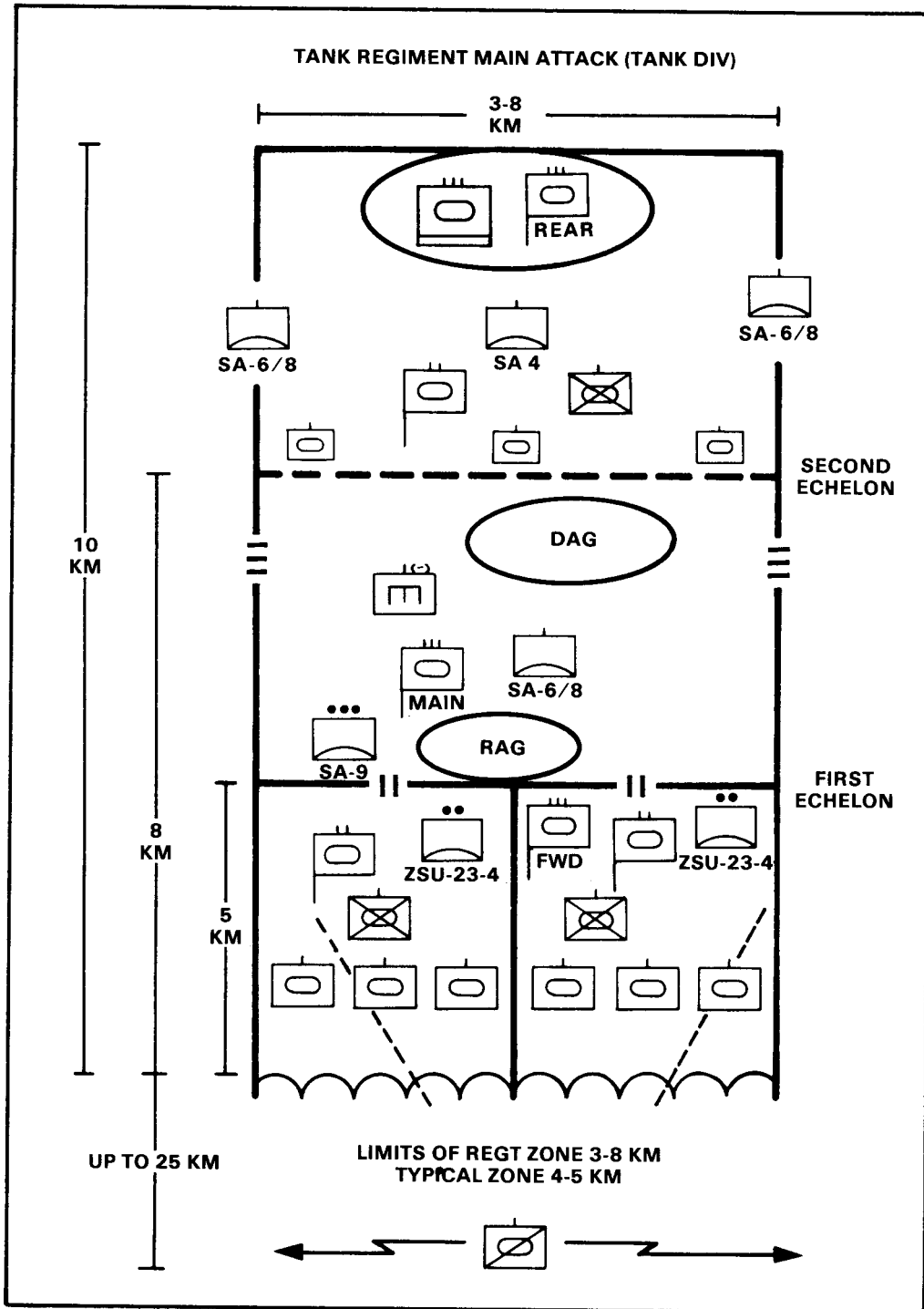

Figure 2-4. Doctrinal template.

e. Function 5 — Threat Integration.

- (1) The battalion S2 relates his threat evaluation to the terrain and weather to predict how the enemy will plan his maneuver in the area of operations. Threat integration is accomplished in the development of situation, event, and decision support templates.
- (2) The situation template is a doctrinal template with terrain and weather constraints applied. The S2 uses common tactical sense and known information to adjust the templates to specific terrain. He develops and templates the most probable course of action and other courses of action as time permits.
- (3) The battalion S2 uses event templating for the identification and analysis of significant battlefield events and enemy activities that provide indicators of the enemy course of action (see Figure 2-4). It is a projection of what will most likely occur if the enemy adopts a particular course of action. By knowing what the enemy can do and comparing it with what he is doing, we may be able to predict what he will do next. As the enemy force is visualized moving along a mobility corridor, critical areas become apparent. These areas are significant because within them, significant events and activities will occur. It is within these areas that targets will appear. These areas are designated as NAI. An NAI is a point or area along a mobility corridor where enemy activity or lack of activity will confirm or deny a particular enemy course of action. NAIs facilitate intelligence collection, reconnaissance and surveillance, and analysis, because attention is focused on areas where the enemy force must appear if it has selected a particular course of action.
- (4) Event templating enables the S2 to develop precise collection requirements, maximizing the effectiveness of limited resources over extended areas against a vast array of enemy targets. It provides answers to the questions where to look, when to look, and what to look for. The situation template and event template enable the S2 to establish collection priorities based on those courses of action the enemy is most likely to adopt. At the task force level, these two templates may be combined.
- (5) The decision support template is the final template of IPB. It does not dictate decisions to the commander, but rather identifies critical events and threat activities relative to time and location which may require tactical decisions. Critical events and threat activities are displayed on the decision

support template using target areas of interest, decision points, and time lines (Figure 2-5).

- (a) A TAI is an area or point usually along a mobility corridor, or is an engagement area (EA) where the interdiction of threat forces by maneuver, fires, and/or jamming will deprive or reduce a particular threat capability.
- (b) A decision point (DP) is a point or area at which a commander must make a decision to engage threat forces. Usually a DP is associated with each TAI. The S2 must recommend DPs in conjunction with the S3.

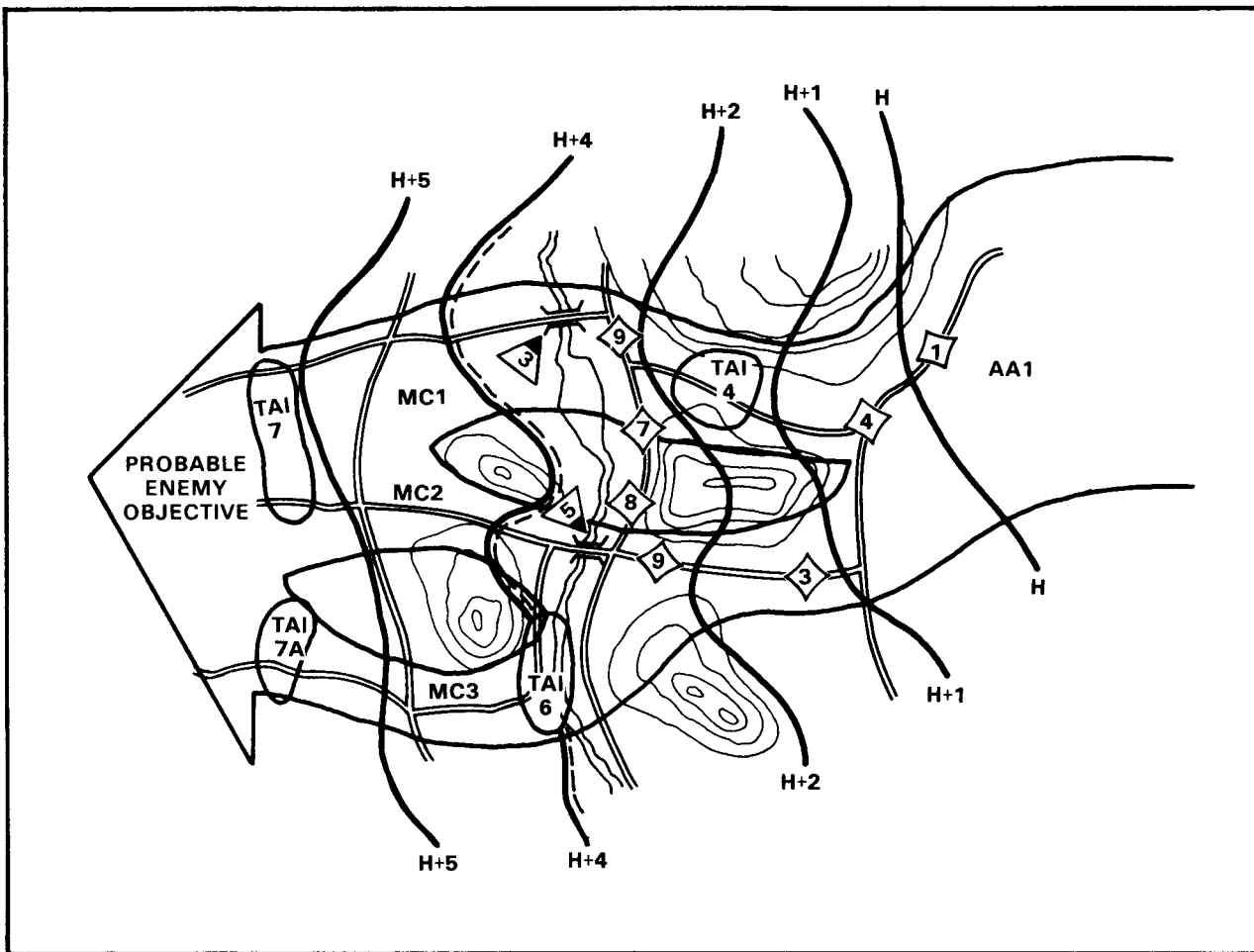

Figure 2-5. Decision support template.

- (c) Time lines are used to depict the maximum extent of enemy advance/withdrawal within a given time. They are adjusted to reflect actual movements. They assist the S2 in verifying movement rates or in adjusting DPs accordingly.
- (6) IPB provides a tool for the systematic analysis of the enemy, weather, and terrain to determine enemy capabilities, vulnerabilities, and probable courses of action in a specific geographic area. IPB is an ongoing process, which involves both the S2 and S3. Properly conducted during the planning and preparation phase, informal IPB helps the task force commander and staff develop courses of action in the manner most likely to produce success and maintain flexibility and freedom of action. During tactical operations, the S2 uses the IPB process to obtain, analyze, and distribute intelligence to maneuver elements. The S2 must sift and analyze volumes of intelligence information and provide the commander his assessment of a most likely course of action.

Section V. COMMAND AND CONTROL COMMUNICATIONS

The commander must understand the capabilities, limitations, and vulnerabilities of his communications system. He should —

- Provide for redundant means of communication.
- Minimize use of the radio by using face-to-face coordination, wire, and messengers when possible.

2-14. COMMUNICATIONS-ELECTRONICS RESPONSIBILITIES

- a. All levels of command must gain and maintain communications with the appropriate headquarters and personnel. The traditional coordination and communications responsibilities are senior to subordinate, supporting to supported, reinforcing to reinforced, from left to right, and from rear to front.
- b. Regardless of the responsibility, all units take prompt action to restore lost communications.
- c. The signal officer establishes communications relays according to the task force commander's directives.

2-15. RADIO NETS

- a. Battalion task force communications are sent over a variety of radio nets. Primary battalion communications nets are —
- (1) **Command net.** A secure command net is used for command and control of the task force. All organic and attached units, including the FSO, FAC, and leaders of supporting elements, enter the task force command net. During the execution of the mission, only commanders transmit; all others monitor and transmit only essential information. The command net is controlled by the task force main CP.
 - (2) **Operation and intelligence (O&I) net.** The O&I net is a secure net established to provide a mechanism for the battalion task force to accept routine items of information concerning operations and intelligence reporting without cluttering or interfering with the battalion command net.
 - (3) **Administrative/logistics net.** The A/L net is a tactical net, controlled by the combat trains CP, used to communicate the administrative and logistical requirements of the task force. All organic and attached units normally operate in this net.
 - (4) **Special radio nets.**
 - (a) The scout platoon net or a designated frequency may function as a surveillance net when required. The S2 and elements assigned surveillance missions operate on this net. Other elements enter or leave the net to pass information as required.
 - (b) The task force FSE and company fire support teams (FISTS) operate in the supporting field artillery command fire direction net and a designated fire direction net to coordinate field artillery fires for the battalion. The TACP operates in US Air Force tactical air-request and air-ground nets to control air strikes.
 - (c) Supporting air defense units monitor the early warning net. In the absence of collocated air defense support, the main CP will also monitor the division early warning net.
 - (d) Attached or OPCON support assets may operate in their parent unit nets, but they must also monitor the command net at all times.
- b. Figure 2-6 illustrates the primary task force FM nets and stations that operate in each net.

	TF CMD	TF O&I	TF A/L	OTHER
CDR	P	-	E	P - BDE CMD
XO	P	-	P	
S3	P	M	-	M - BDE CMD
MAIN CP (S3)	NCS	-	M	P - BDE CMD
MAIN CP (S2)	M	NCS	-	P - BDE O&I
COMBAT TRAINS CP	M	-	NCS	P - BDE A/L
SIGNAL OFFICER	M	E	M	E - AS REQUIRED
FSO	M	-	-	M - TF FD, FS NETs
FAC	M	E	-	P - AIR FORCE NETs
S1	-	-	M	
S4	M	-	P	E - AS REQUIRED
BMO	-	-	P	
SPT PLT	M	-	P	
MED PLT	-	-	P	
CO/TM CDRs	P	E	-	P - CO/TM CMD
CO/TM XOs	M	-	E	P - CO/TM CMD
CO/TM 1SG	-	-	P	P - CO/TM CMD
ENGR PLT	M	E	E	P - ENGR PLT
SCOUT PLT	P	P	E	P - SCOUT PLT
ADA PLT	M	E	E	P - ADA PLT; EW
MORTAR PLT	M	-	E	NCSS - TF FD NET
GSR	M	P	E	
HHC CDR	-	-	P	P - BDE A/L
LO	M	E	-	M - AS ASSIGNED

NCS - NET CONTROL STATION FOR NET

P - PRIMARY USERS - MONITOR AND TRANSMIT

M - MONITOR NET, TRANSMIT AS REQUIRED

E - ENTER NET TO TRANSMIT MESSAGE, THEN RETURN TO PRIMARY NET

Figure 2-6. Task force FM nets/stations matrix.

2-16. EAVESDROP SYSTEM

Eavesdrop is a technique used on all nets from task force command down to platoon nets.

- a. This technique requires all stations to monitor and use message traffic on a given net, even if they are not the direct recipients

of the message. For example, command net traffic is sent from a company team commander to the task force commander or S3 at the tactical CP. The other company team commanders and main CP monitor this traffic, update situation maps, and take appropriate action. In this way, all stations will have an understanding of the situation without requiring the same information to be transmitted by the NCS.

- b. Additionally, operations may require continuous monitoring of a subordinate or adjacent unit net. In this case, the main CP eavesdrops on the selected net and ensures information critical to task force operations is retransmitted over the appropriate battalion nets.

2-17. MOBILE SUBSCRIBER EQUIPMENT

MSE terminals with tactical facsimile (TACFAX) connectors are located at the main CP and the combat trains CP. They provide a rapid, secure means of transmitting and receiving OPODs and lengthy CSS reports between the task force and brigade. Any MSE terminal provides access to the entire corps network.

2-18. COMMUNICATIONS SECURITY AND ANTIJAMMING

- a. Communications security denies or delays unauthorized persons from gaining communications information. Techniques include —
 - Using authentication procedures.
 - Changing frequencies and call signs.
 - Restricting use of radio transmitters.
 - Using wire or messenger.
 - Reducing transmission time.
 - Frequent authentication.
- b. Antijamming procedures used by radio operators include —
 - Use of low power.
 - Antenna masking and directional antennas.
 - Continued operation and reporting.
 - Surreptitiously switching frequencies.

Section VI. OTHER COMMAND AND CONTROL PROCEDURES

This section describes additional procedures which enhance command and control.

2-19. OPERATIONS SECURITY

OPSEC denies the enemy information about planned, ongoing, and after-operation activity until it is too late for enemy forces to react effectively. OPSEC must be maintained throughout all phases of an operation. It is an integral part of planning, unit training, and combat operations at all levels of command.

- a. The S3 has primary staff responsibility for OPSEC within the task force. He is assisted by the S2, who provides information on the enemy's collection capabilities.
- b. There are three types of OPSEC protective measures: countersurveillance, countermeasures, and deception.
 - (1) Countersurveillance includes all measures (ground, air, or electronic) taken to protect the status of friendly activities and operations, such as those measures taken to defeat enemy reconnaissance. Countersurveillance of enemy air is accomplished primarily through camouflage, cover, and concealment and by use of air defense assets. Countering enemy ground reconnaissance is accomplished through active and aggressive counterreconnaissance measures.
 - (2) Countermeasures are actions taken to eliminate or reduce the intelligence and electronic warfare threat. These actions may be anything from deception to destruction of the enemy collection capability. Countermeasures include —
 - Vehicle camouflage.
 - Light and noise discipline.
 - Challenge and password.
 - (3) Tactical deception includes those measures taken to create a false picture of friendly activities and operations. The deception must be believable and must make the enemy do something or not do something that supports the commander's concept. Deception helps to establish the conditions for surprise. Maneuver plans that avoid obvious patterns or solutions can be integrated with deception to achieve surprise.

- (a) Deception operations may include –
- Feints and ruses.
 - Demonstrations.
 - Dummy equipment and positions.
 - Falsification of material placed where it can be captured or photographed by the enemy.
 - Manipulation of electronic signals.
- (b) Most deception operations are planned and directed at levels above battalion. Means of deception at battalion are —
- Visual — showing movement, equipment, and activity at a believable time in a believable place. This can be actual or dummy.
 - Sound — engines running, track noise, hatch closing, digging, and gunfire.
 - Odor — diesel fumes and cooking odors.
 - Electronics — false transmission, remote locations for radios, and radar scan of areas other than those of primary interest.
 - Thermal — false heat sources.
- (c) Deception techniques can be combined in various ways. For example, a small force can simulate a larger one by making the noises of a larger force; having some actual and some dummy positions; raising dust clouds by having vehicles dragging chains or tree branches; moving a force across an observable area, then returning it under cover and presenting it again and again; creating extra radio stations to simulate traffic of a larger unit; and in many other ways. The commander must think of security (all types) and deception as combat multipliers. Military intelligence support can often assist in these activities. (See FM 90-2.)

2-20. FIRE CONTROL

Control of battalion task force fires is critical to the effective employment and massing of available fire support. Fire control is used with maneuver to bring the maximum available direct and indirect fires on the enemy's positions or formation while avoiding the mistaken engagement of friendly forces (fratricide). A normal

part of a company team's mission is telling it where, when, and what to engage by direct and indirect fire.

Fires should be distributed to completely cover the enemy. Ideally, each weapon should fire at a different target or part of the enemy. With the lethality of modern weapons, multiple engagements of the same enemy target waste ammunition and lessen the ability to quickly destroy the enemy.

Fire control measures are used to distribute fires, designate targets, and protect friendly forces. Fire control measures normally used by the battalion task force are —

- Sectors of fire.
- TRPs and EAs.
- Restrictive the control measures.
- Priorities of engagement.
- Pyrotechnics and visual markers.
- Checkpoints and trigger points.

CHAPTER 3

OFFENSIVE OPERATIONS

The offensive is the decisive form of war. AirLand Battle doctrine seeks to quickly seize the initiative. The commander selects the time and place to concentrate and synchronize task force combat elements to overcome the enemy's defense; to destroy his command, control, and communications system; and to defeat him in detail.

CONTENTS	
PARAGRAPH	PAGE
Section I. FUNDAMENTALS OF OFFENSIVE OPERATIONS	3-2
3-1 Purpose of the Offensive	3-2
3-2 Characteristics of Offensive Operations	3-2
3-3 Types of Offensive Operations	3-4
3-4 Sequence of an Attack	3-4
3-5 Forms of Maneuver	3-5
3-6 Movement Techniques and Formations	3-10
Section II. THREAT DEFENSIVE DOCTRINE	3-16
3-7 Why the Threat Defends	3-16
3-8 How the Threat Defends	3-17
Section III. PLANNING FOR OFFENSIVE OPERATIONS	3-19
3-9 Offensive IPB and Reconnaissance	3-19
3-10 Reconnaissance and Surveillance Planning	3-19
3-11 Concept of Operation	3-22
3-12 Main and Supporting Attacks.	3-25
3-13 Company Team Missions in the Attack.	3-27
3-14 Reserve Considerations	3-27
3-15 Synchronization of Offensive Operations	3-28
3-16 Planning Considerations for Night Attacks	3-32
3-17 Bypass Planning Considerations	3-35
3-18 Assaults and Actions on the Objective	3-37
3-19 Consolidation and Reorganization	3-38
3-20 Offensive Control Measures	3-39
Section IV. CONDUCTING ATTACKS	3-42
3-21 Movement to Contact	3-42
3-22 Meeting Engagement and Actions on Contact	3-48
3-23 Hasty Attack	3-49
3-24 Deliberate Attack	3-52
3-25 Techniques for the Deliberate Attack	3-54
3-26 Attack of a Strongpoint	3-58

PARAGRAPH	PAGE
Section V. OTHER OFFENSIVE OPERATIONS	3-62
3-27 Exploitation	3-62
3-28 Pursuit	3-63
3-29 Reconnaissance in Force	3-64
3-30 Attacks from a Defensive Posture	3-64
3-31 Follow-and-Support	3-66
3-32 Raid	3-67
3-33 Feint	3-69
3-34 Demonstration	3-69

Section I. FUNDAMENTALS OF OFFENSIVE OPERATIONS

3-1. PURPOSE OF THE OFFENSIVE

The task force conducts offensive operations to achieve one or more specific purposes:

- Defeat enemy forces.
- Secure key or decisive terrain.
- Deprive the enemy of resources.
- Gain information.
- Deceive and divert the enemy.
- Hold the enemy in position.
- Disrupt an enemy attack.

3-2. CHARACTERISTICS OF OFFENSIVE OPERATIONS

Battalion task force offensive operations are characterized by surprise, concentration, speed, flexibility, and audacity.

- a. **Surprise.** Surprise is achieved when the enemy cannot react effectively to the task force commander’s scheme of maneuver. Surprise may be achieved by —
- Conducting thorough reconnaissance and surveillance.
 - Striking the enemy from an unexpected direction at an unexpected time.
 - Employing deception efforts.

- b. **Concentration.** Concentration is the massing and synchronization of overwhelming combat power against an enemy weakness. Concentration is achieved by —
- Planning on the basis of information generated by aggressive reconnaissance.
 - Fixing the enemy to prevent his reaction to maneuver.
 - Rapidly massing forces and fires to overwhelm the enemy defense.
 - Synchronizing maneuver with combat support.
- c. **Speed.** The task force moves quickly to take advantage of enemy weaknesses. Speed in execution is key to denying the enemy time to reposition or reorient to meet an attack. Speed is achieved by —
- Planning and rehearsing battle drills.
 - Conducting route reconnaissance.
 - Wargaming contingencies with subordinate leaders.
 - Exercising responsive command and control.
 - Issuing mission-type orders.
 - Using routes, movement techniques, and formations that allow the force to move rapidly and with security.
 - Isolating enemy forces through fixing and suppressing fires.
 - Providing rapid resupply with logistics packages (LOGPACs) to sustain the task force's offensive capability.
 - Maintaining momentum to keep the enemy from reestablishing his defense.
- d. **Flexibility.** Flexibility is the ability to divert from the plan and exploit success by maintaining freedom of maneuver. Flexibility in planning results from wargaming. Flexibility is achieved by —
- Aggressive reconnaissance that continues to seek enemy weaknesses and ways to attack him from his flanks and rear.
 - A reserve that can assume the mission of the main attack or exploit an enemy weakness. A reserve is the commander's primary means of maintaining flexibility.
 - A command and control system that allows the commander to rapidly transmit decisions during the battle.
 - The use of FRAGOs, checkpoints, and reserve graphic control measures.
 - Contingency planning that permits shifting the main effort.

- e. **Audacity.** Audacity is the willingness to risk bold action to win. The audacious commander is quick and decisive, and willing to take prudent risks. He bases his decisions on sound tactical judgment, personal observation of the terrain, and first-hand knowledge of the battle. He constantly seeks to attack the enemy on the flanks or rear and to rapidly exploit success. He shares the hazards of the battlefield with his troops, moving to the critical places to lead by example.

3-3. TYPES OF OFFENSIVE OPERATIONS

- a. There are five major types of offensive operations in which the task force participates:
 - Movement to contact.
 - Hasty attack.
 - Deliberate attack.
 - Exploitation.
 - Pursuit.
- b. The task force normally participates in these operations as part of a larger force. Commanders at each level —
 - Find or create a weak point.
 - Suppress enemy fires.
 - Isolate the enemy and maneuver against weak points.
 - Exploit success.

3-4. SEQUENCE OF AN ATTACK

Generally, the following sequence is followed in task force attacks:

- a. **Reconnaissance.** Reconnaissance begins as soon as possible after the task force receives its mission. Information on the avenues of approach, obstacles, and the enemy positions is critical to planning the attack. Reconnaissance continues throughout the attack.
- b. **Movement to a Line of Departure.** When attacking from positions not in contact, task forces often stage in rear assembly areas, road march to attack positions behind friendly units in contact with the enemy, conduct a passage of lines, and begin the attack.

- c. **Maneuver.** The task force maneuvers to a position of advantage.
- d. **Deployment.** The task force deploys to attack or to fix the enemy if bypassing.
- e. **Attack.** The enemy position is attacked by fire, assaulted, or bypassed.
- f. **Consolidation and Reorganization or Continuation.** The task force eliminates resistance and prepares for or conducts further operations

3-5. FORMS OF MANEUVER

Task force attacks are of two basic types: hasty and deliberate. The two are distinguished primarily by the time available for planning and the extent of preparation. In either case, the attack is violent, resolute, and synchronized.

- a. The basic forms of maneuver used in the attack are envelopment, turning movement, infiltration, penetration, and frontal attack. Frequently, attacks will use more than one form of maneuver such as an initial penetration that leads to an envelopment.
- b. The higher commander seldom directs the form of maneuver to be used by the battalion task force.
 - (1) **Envelopment.** An envelopment is the preferred form of maneuver. In an envelopment, the attacker strikes the enemy's flank or rear (see Figure 3-1, page 3-6). The envelopment causes the enemy to fight in a direction from which he is less prepared. Envelopment requires an assailable flank, found primarily by aggressive reconnaissance. Enemy weapons orientations and obstacles determine assailable flanks — not the attacker's direction of movement.
 - (a) When the task force conducts an envelopment, one or more companies or teams normally make supporting attacks to fix the enemy while other companies of the task force maneuver against the enemy's flank or rear. The supporting attack must have sufficient combat power to keep the enemy fully engaged while the enveloping force closes. When part of a larger unit's envelopment, the task force may be either the enveloping force or the fixing force.
 - (b) The enveloping force may be mounted or dismounted, but it must have the mobility and combat power to achieve its purpose.

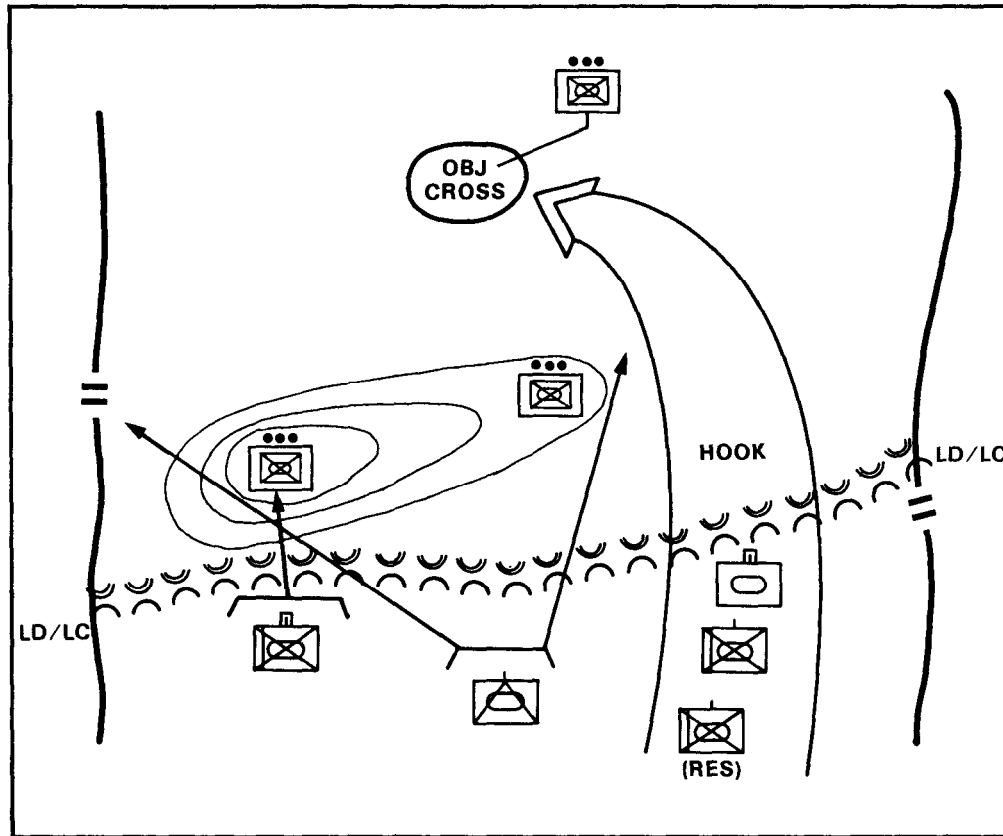

Figure 3-1. Battalion task force conducting an envelopment.

(c) Variations of the envelopment include double envelopment and encirclement.

- In the *double envelopment*, the attacker seeks to pass simultaneously around both flanks of the enemy. This requires two assailable flanks. Precise coordination, sufficient combat power, and detailed timing are required. The double envelopment is seldom attempted at task force level.
- An *encirclement* occurs when the defender has lost all ground routes of evacuation and reinforcement. Task forces normally participate in encirclements as part of a larger force. Encirclements are likely to be made during an exploitation or pursuit.

(2) **Turning movement.** The turning movement is a variant of the envelopment in which the attacker seeks to pass around the enemy, avoiding his main forces, to secure an objective

deep in the rear. The task force normally conducts a turning movement as part of a larger unit's operation.

- (3) **Penetration.** In the penetration, the battalion concentrates its force to rupture the defense on a narrow front, normally a platoon. The gap created is then widened and used to pass forces through to defeat the enemy in detail and to seize objectives in depth. A successful penetration depends on surprise and the attacker's ability to suppress enemy weapons, to concentrate forces at the point of attack, and to quickly pass sufficient force through the gap to destroy the enemy's defense. A penetration is normally attempted when enemy flanks are unassailable, or when the enemy has a weak or unguarded gap in his defense. The penetration of a well-organized position requires a quick rupture and a rapid destruction of the continuity of the defense to deny the enemy time to react. Without rapid penetration, the enemy can reposition forces to block or counter the maneuver. A penetration is planned in three phases:

- (a) Isolation of the site selected for penetration (see Figure 3-2).

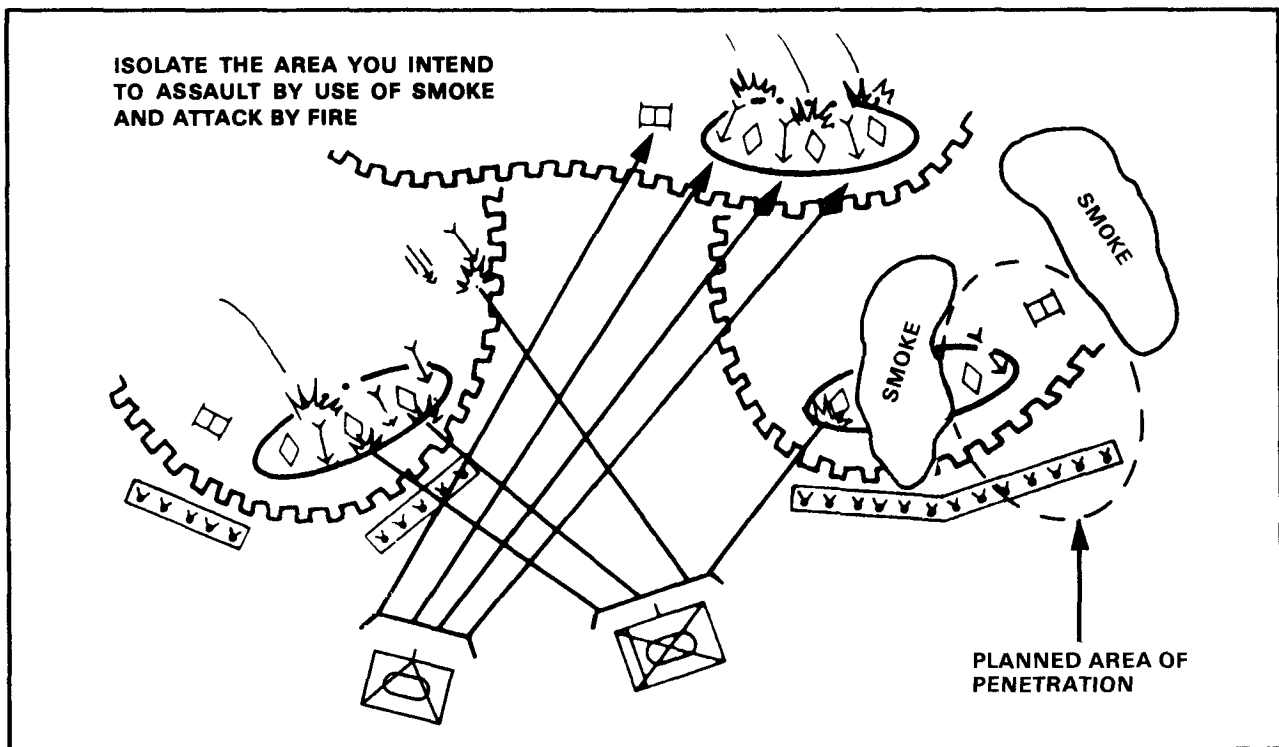

Figure 3-2. Penetration (Step 1).

- (b) Initial penetration of the enemy position (see Figure 3-3). Dismounted infantry company teams breach the close-in obstacles and seize enemy positions behind these obstacles. These teams widen and hold the shoulders of the initial penetration. This penetration is over-matched and supported by other elements of the task force.

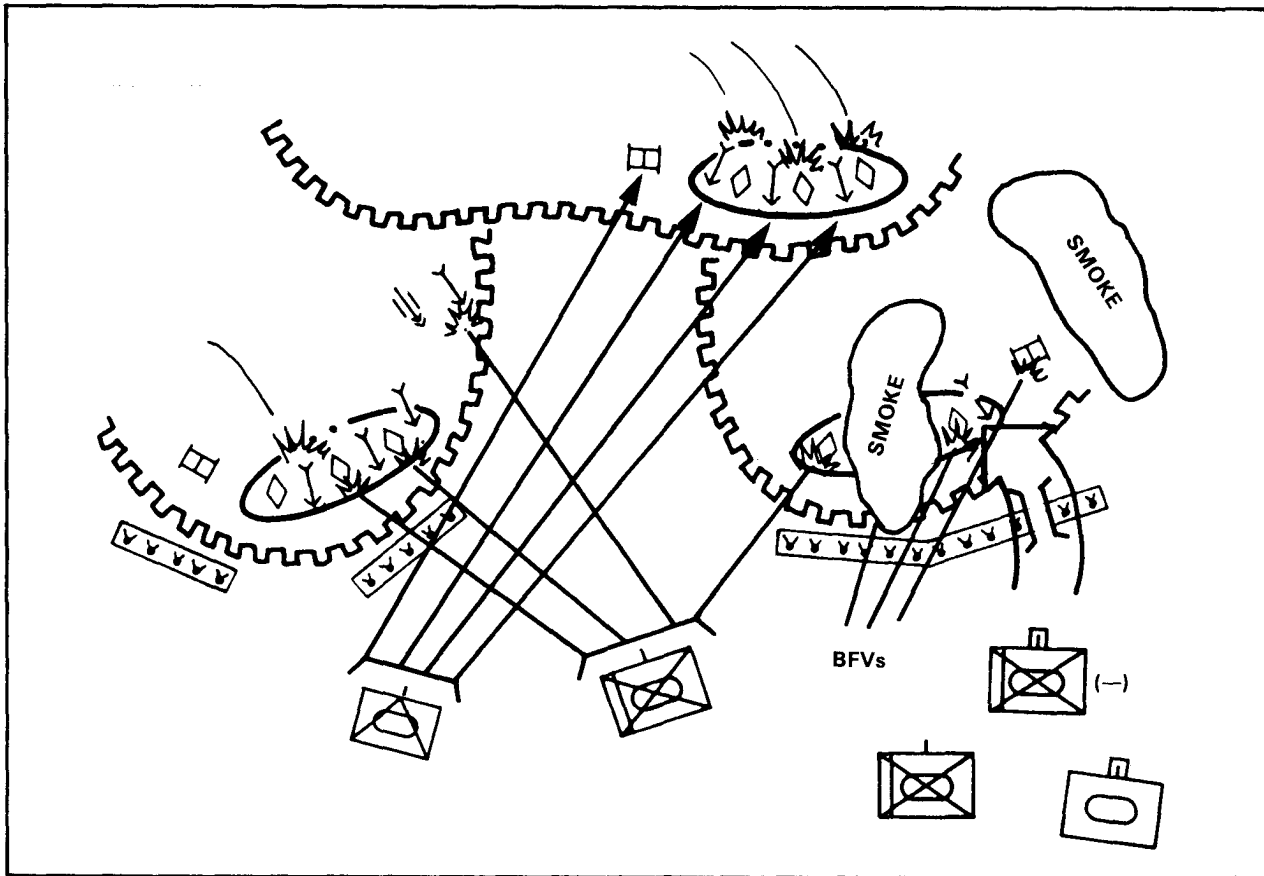

Figure 3-3. Penetration (Step 2).

- (c) Exploitation of the penetration (see Figure 3-4). Other companies complete the destruction of the enemy position and move to deeper objectives. Objectives for the exploitation force are at least deep enough to allow an envelopment of the rest of the enemy company position. These objectives allow attack by fire to be made against second echelon enemy positions and enemy counterattack routes.

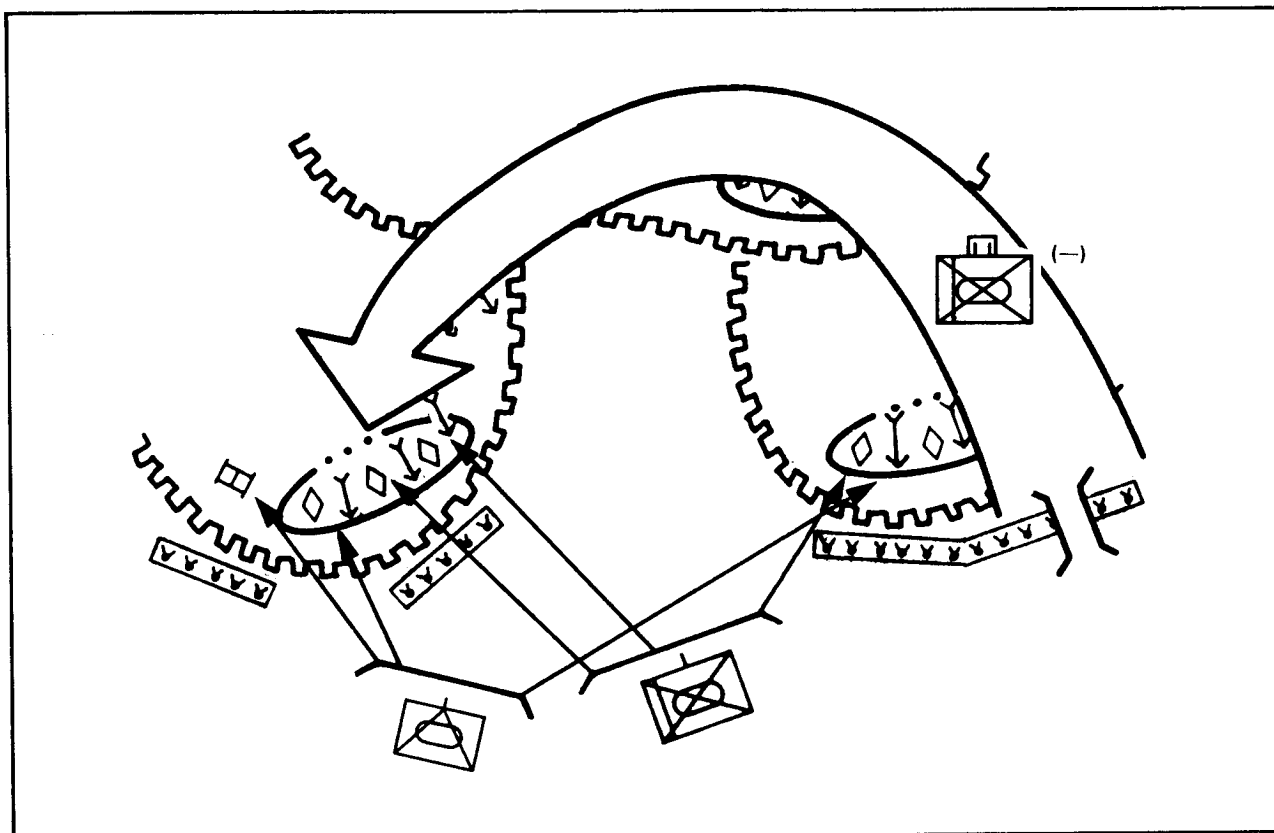

Figure 3-4. Penetration (Step 3).

- (4) **Frontal attack.** The frontal attack is the least preferred form of maneuver. In the frontal attack, the task force uses the most direct routes to strike the enemy along his front. This attack is normally employed when the mission is to fix the enemy in position or deceive him. Although the frontal attack strikes the enemy's front within the zone of the attacking force, it does not require that the attacker do so on line or that all subordinate unit attacks be frontal. Frontal attacks, unless in overwhelming strength, are seldom decisive.
- (5) **Infiltration.** Infiltration is a form of maneuver where combat elements move by stealth to objectives to the rear of the enemy's position without fighting through prepared defenses. All or part of the task force may move by infiltration. Infiltrations are slow and are often conducted during reduced visibility. Successful infiltration requires effective reconnaissance to discover and secure undefended

routes. Such routes are normally found in rough terrain or in areas difficult to cover with observation and fire. The infiltrating elements avoid detection, but if detected they avoid decisive engagement.

3-6. MOVEMENT TECHNIQUES AND FORMATIONS

The selection of movement techniques and attack formations for the task force is dependent on terrain, the mission, and the overmatching capability of the force's weapons systems.

- a. **Movement Techniques.** The three movement techniques are traveling, traveling overwatch, and bounding overwatch. Usually, the task force does not move as a unit using one movement technique. Rather, the task force commander designates the movement technique to be used by the lead unit(s). Movement techniques end upon enemy contact. The unit begins its actions on contact and the overmatching force begins its suppressive fire.
- b. **Formations.** The task force may move in any one of six basic formations: column, wedge, V, echelon, line, and box or diamond. The task force may use more than one formation in a given movement; this is especially true when the terrain changes during the movement. For example, the task force commander may elect to use the column formation until the task force clears a defile, at which time the task force would change to another formation, such as a wedge. Other factors, such as the distance of the move or the enemy disposition, may also prompt the commander to use more than one formation. Distances between units are METT-T dependent.
 - (1) **Column formation.** The task force moves in column formation when early contact is not expected, and the objective is far away. Normally the battalion's lead element uses traveling overwatch while the following units are traveling (see Figure 3-5). Considerations are as follows:
 - Facilitates speed of movement, easy to control, and useful in defiles or dense woods.
 - Provides for quick transition to other formations.
 - Requires flank security.
 - Provides majority of firepower to the flanks.

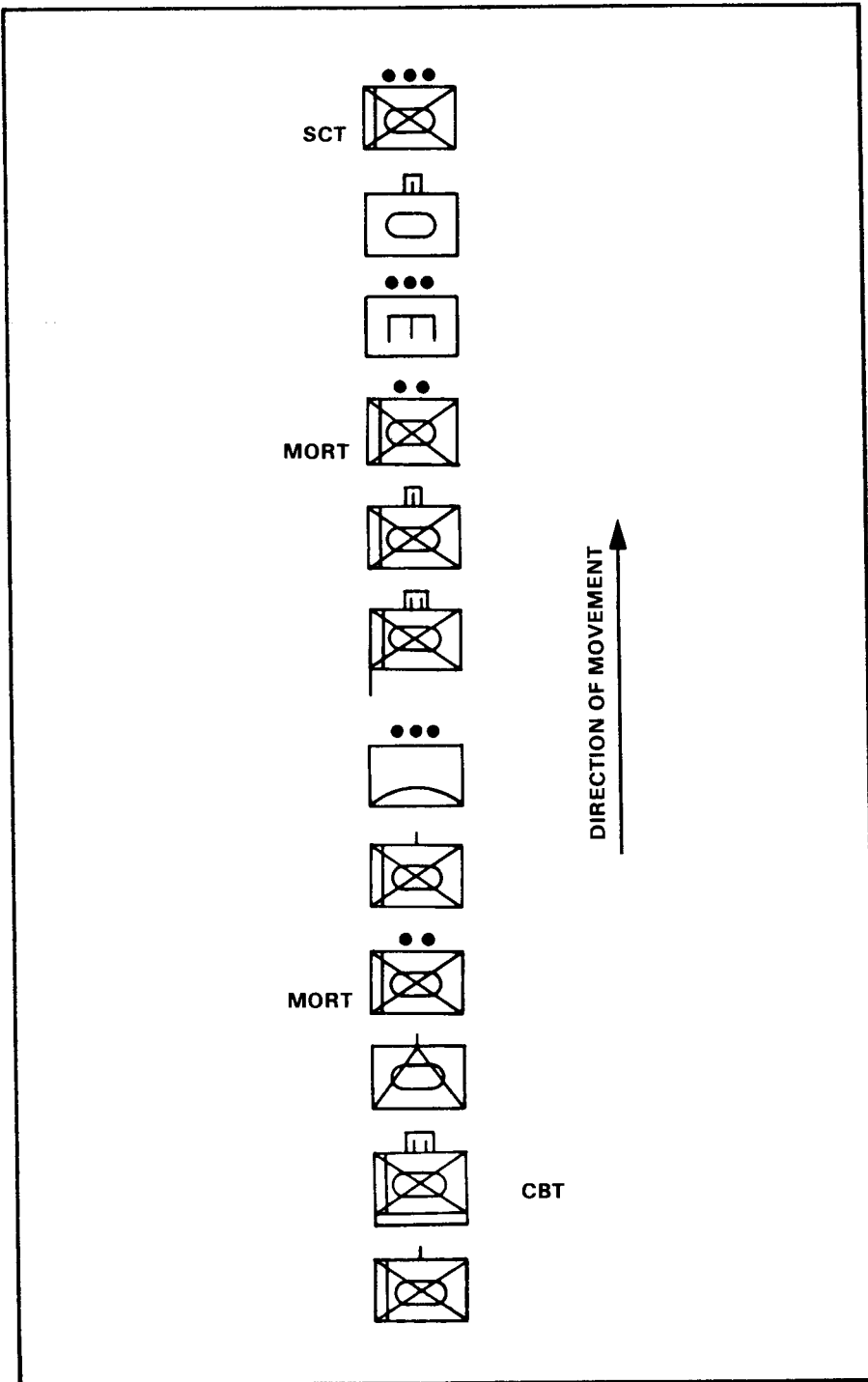

Figure 3-5. Task force in column formation.

(2) **Wedge formation.** The wedge formation best positions the battalion to attack an enemy appearing to the front and flanks. The wedge is used when enemy contact is possible or expected, but the location and disposition of the enemy is vague. When enemy contact is not expected, it may be used to rapidly cross open terrain (see Figure 3-6). Considerations are as follows:

- Facilitates control and transition to the assault.
- Provides for maximum firepower forward and good firepower to the flanks.
- In forested areas or during poor visibility, is difficult to control.
- Requires sufficient space to disperse companies laterally and in depth.

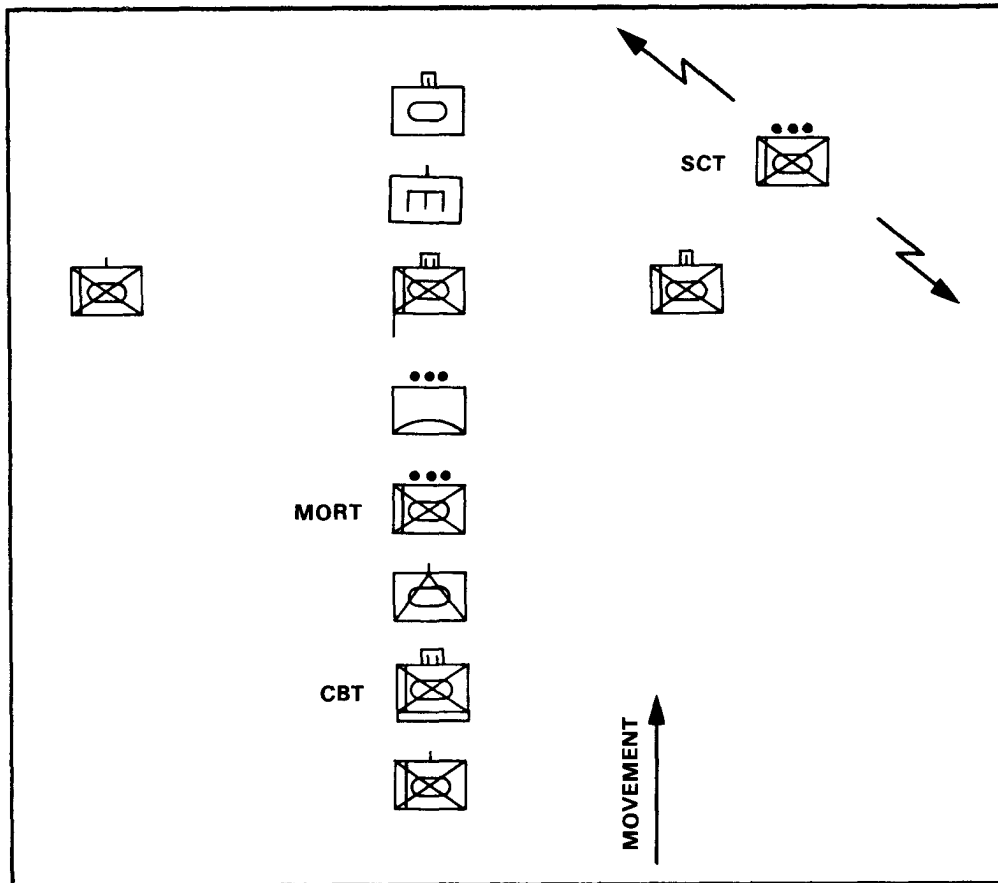

Figure 3-6. Task force in wedge formation.

(3) **V formation.** The V formation disposes the task force with two companies abreast and one trailing. This arrangement is most suitable to advance against a threat known to be to the front of the task force. It may be used when enemy contact is expected and the location and disposition of the enemy is known (see Figure 3-7). Considerations are as follows:

- Hard to reorient control is difficult in heavily wooded areas.
- Provides for good firepower forward and to the flanks.

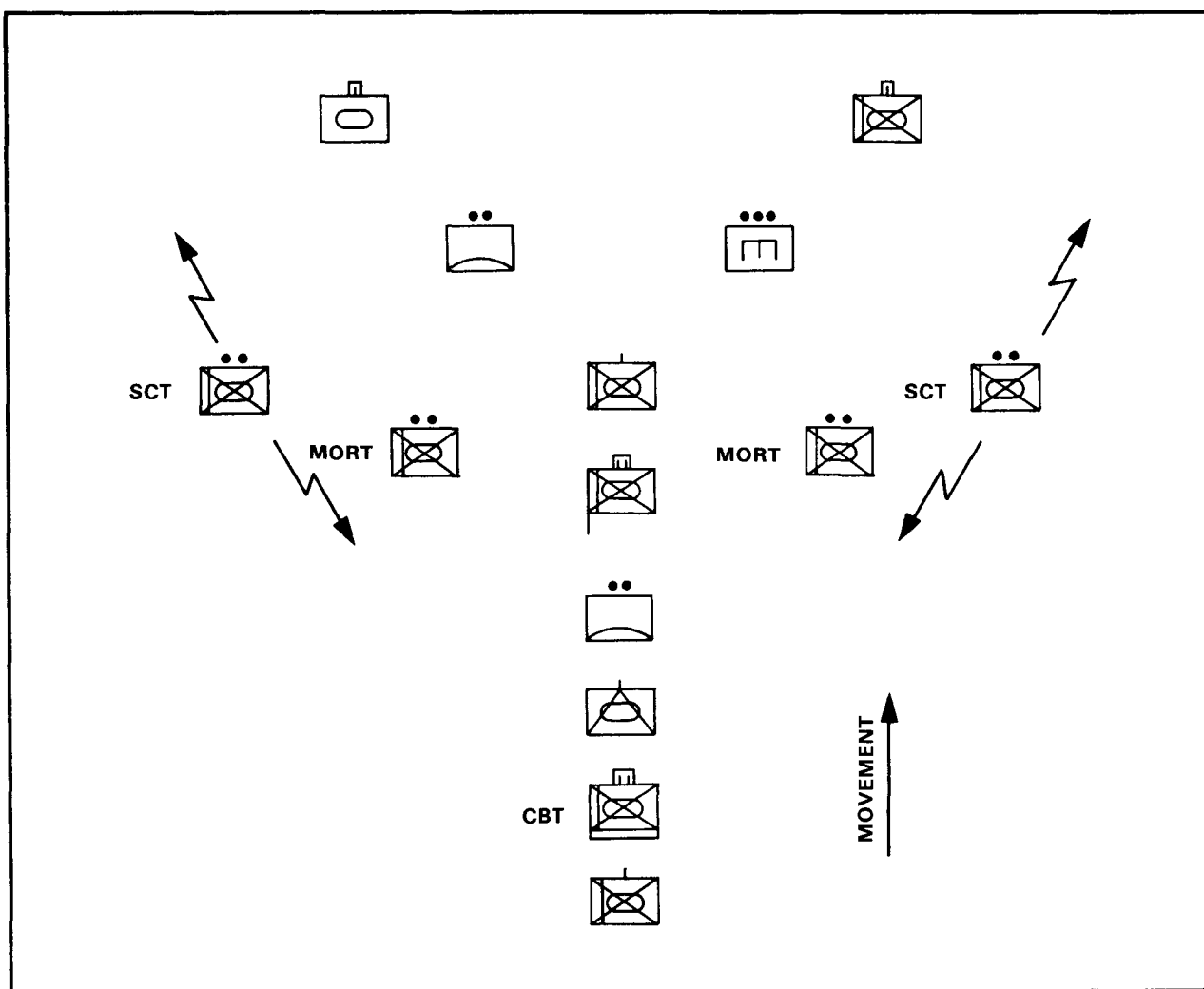

Figure 3-7. Task force in V formation.

(4) **Echelon formation.** The echelon formation arranges the task force with the company teams in column formation in the direction of the echelon (right or left). It is commonly used when the task force provides security to a larger moving force (see Figure 3-8). Considerations are as follows:

- Provides for firepower forward and in the direction of echelon.
- Facilitates control in open areas; more difficult in heavily wooded areas.

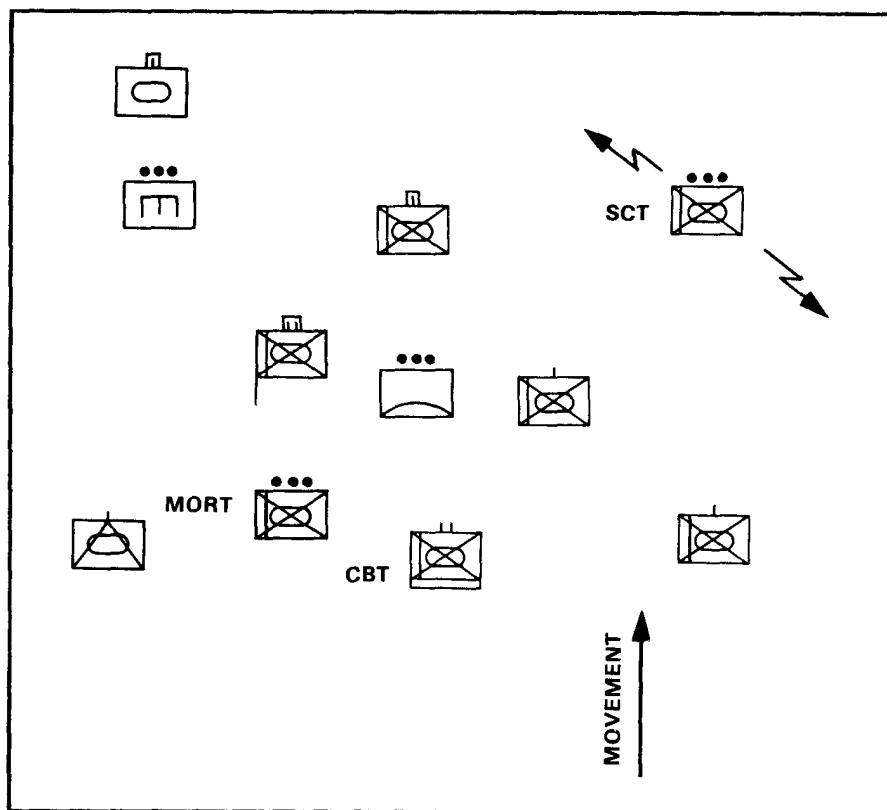

Figure 3-8. Task force in echelon (right) formation.

(5) **Line formation.** The line formation arranges the task force with company teams abreast. Since it does not dispose company teams in depth, the line provides less flexibility of maneuver than other formations. It is used when continuous movement with maximum firepower to the front is required (see Figure 3-9). Considerations are as follows:

- Permits maximum firepower to the front.

- Difficult to control.
- Facilitates the use of speed and shock in closing with the enemy.

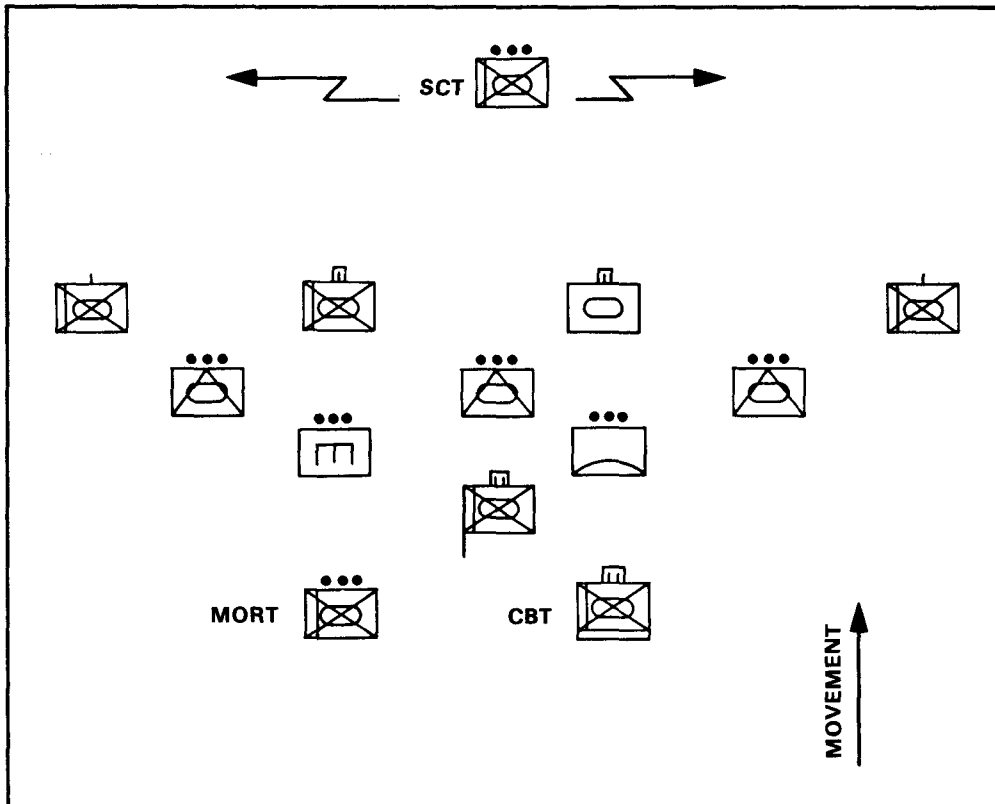

Figure 3-9. Task force in line formation.

- (6) **Box formation.** The box formation arranges the battalion with two company teams forward and two company teams trailing. It is the most flexible of all formations because it can easily be changed to any other formation (see Figure 3-10, page 3-16). Considerations are as follows:
- Provides firepower to the front and flanks.
 - Facilitates speed of movement because it is easy to control.
- (7) **Diamond formation.** The diamond formation is a variation of the box formation. In the diamond formation, one company team leads, one company team is positioned on each flank, and the remaining company team is to the rear.

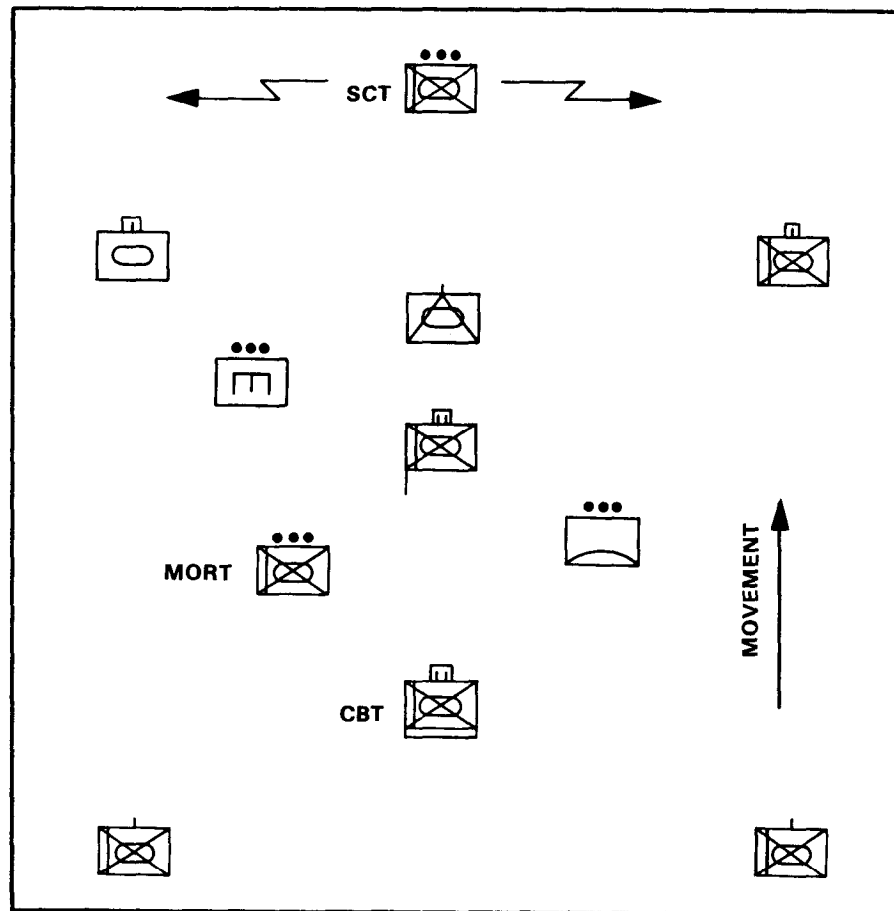

Figure 3-10. Task force in box formation.

Section II. THREAT DEFENSIVE DOCTRINE

3-7. WHY THE THREAT DEFENDS

Threat doctrine prescribes offense as the principal combat operation and views the defense as necessary at times, but always temporary in nature. Threat commanders resort to defense to economize forces, gain time, concentrate forces for further offensive operations, repel a stronger force, consolidate an objective, or cover a withdrawal.

- a. While he defends, the threat commander will focus on containment of an attack, and violent counterattacks to defeat committed

troops and regain the initiative. The threat integration of electronic warfare and smoke into his defensive plan is routine.

- b. Tactically, threat defensive operations seek surprise, employ large concentrations of troops and fires, integrate combined arms, and provide defense in depth. The threat defense is designed to hold an occupied area and repulse attacks by exhausting attacking forces, methodically depleting their strength, and then counterattacking.

3-8. HOW THE THREAT DEFENDS

The threat normally uses motorized rifle units to defend and uses tank forces in the counterattack (see Figure 3-11, page 3-18).

- a. The threat perceives the hasty defense as the most probable form of defense, as it allows for a rapid transition to offensive operations. It is during the hasty defense that he is most vulnerable to an attack. When the threat advance is halted for more than a few hours, he makes the transition from a hasty defense to a prepared defense organized in successive belts and echelons to provide depth.
- b. A threat defense consists of a security zone and a main defense belt. The attacker is faced with a series of mutually supporting platoon and company battle positions or strongpoints echeloned in depth. Obstacles are prepared forward of and within each defense belt to impede the attacker's advance, canalize him into "fire sacks," or expose him to counterattacks by tank-heavy reserves. Security zone forces try to halt or delay the attacker by forcing him to deploy before reaching the main defense belt.
- c. The following are strengths of the threat defense.
 - (1) Mechanized and armored formations fight as a combined arms team.
 - (2) Heavy attack helicopters are used against close targets; fixed-wing aircraft attack artillery units, nuclear delivery systems, and other deep targets.
 - (3) Massive amounts of field artillery can be brought to bear. Each frontline division has 140 tubes, and with normal reinforcement can have up to 260 tubes of artillery.
 - (4) Counterfire and close support missions are fired simultaneously.
 - (5) The defense is antitank and strongpoint oriented with tank-heavy mobile reserves.

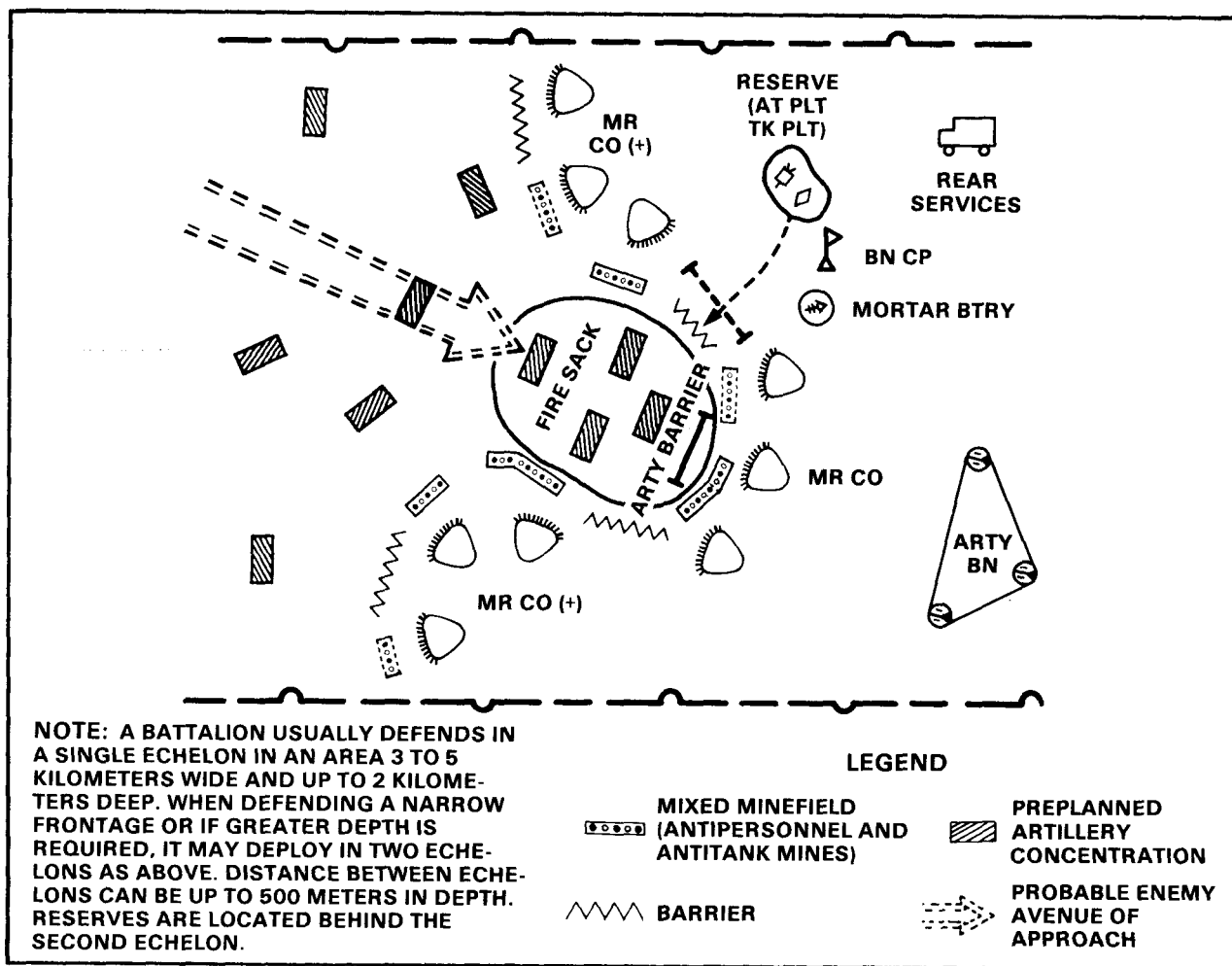

Figure 3-11. Reinforced motorized rifle battalion in the defense.

- d. Vulnerabilities and weaknesses of the threat defense are as follows.
- (1) Communications are excellent; however, at platoon level, primary command and control is with visual signals.
 - (2) Artillery command observation posts (COP) are the heart of the fire support system.
 - (3) Illumination and pyrotechnics are used to mark counterattack objectives at night. (Poor passive night vision capability.)
 - (4) Threat concept for continuous operations requires active infrared lights.

Section III. PLANNING FOR OFFENSIVE OPERATIONS

3-9. OFFENSIVE IPB AND RECONNAISSANCE

- a. Offensive IPB coupled with aggressive reconnaissance provides the commander the following information:
 - Location of existing and reinforcing obstacles.
 - Enemy positions and orientations.
 - Enemy intent based on his dispositions.
 - Avenues of approach to exploit enemy weaknesses.
 - Likely courses of action for employment of enemy reserves, counterattacking forces, and CS assets.
- b. From the analysis of the enemy's scheme of defense, the commander develops a tentative plan to defeat it.
- c. The enemy's defensive positions and terrain critical to the scheme of maneuver must be kept under observation to ensure that the enemy does not modify his defenses while the task force plan is being finalized and coordinated. Supporting and direct fires are used to impede enemy preparations to the degree practical and desirable.
- d. Reconnaissance assets may also be used to assist friendly movement.

3-10. RECONNAISSANCE AND SURVEILLANCE PLANNING

- a. Reconnaissance and surveillance operations are planned by the S2 and coordinated with the S3 to confirm or deny the S2's templating.
 - (1) Reconnaissance is continually conducted to collect information on which the commander plans, makes decisions, and issues orders. It concentrates on one or more specific target areas without the requirement for continuous coverage. The scout platoon is the unit in the task force dedicated to the reconnaissance mission, but all elements of the task force are required to assist in the reconnaissance effort. Other assets must be requested from higher headquarters.
 - (2) Surveillance is the systematic observation of areas by visual or other detection means for intelligence purposes. A surveillance mission is characterized by the greater size of

its target area and by repetition. Under optimum conditions, surveillance is continuous over the entire area of interest. The task force S2 requests that brigade provide surveillance of critical areas outside the task force area of operations.

b. Reconnaissance and surveillance operations are conducted by various elements:

- (1) **Scouts.** These are the soldiers best trained to function as the “eyes” and “ears” of the task force. They are used in the area hardest to cover. Scouts reconnoiter to determine enemy locations, orientations, and dispositions. Before, during, and after the battle, they continue to report their observations and significant changes in enemy activity.
- (2) **Ground surveillance radars.** A GSR can detect moving vehicles and personnel in open terrain at long ranges, and it can provide information on the number, location, disposition, and types of targets. Normally, GSRs are placed to cover open, high-speed approaches where early detection is critical. They are also used to monitor defiles and to detect enemy reconnaissance elements by oblique shots across the task force’s sector along open, flat areas.
- (3) **Remote sensor teams.** Remotely employed sensors (REMS), like GSR, are division assets attached or placed in direct support. The battalion must provide the manpower to emplace REMS; the team leader monitors the output for the S2. The REMS should be emplaced as far forward as possible. They are useful in covering dead space and broken terrain where observation would require more OPs or patrols than available. They can also assist in detecting attempts to breach friendly obstacles and in keeping track of enemy movements after security force withdrawal.
- (4) **Infantry.** Manning OPs and patrolling are infantry missions.
- (5) **Tanks.** While tank units are not manned to conduct patrols and man OPs, their use should be planned. The thermal sights are a useful means of detecting vehicle movement.

c. **Planning considerations.**

- (1) The S2 coordinates efforts of all intelligence resources into one collection effort.
- (2) Intelligence requirements (IR) are prioritized for R&S missions, and further refined as specific instruction orders.

- (3) Economy of effort is necessary in planning the use of resources for maximum return. Duplication of effort is eliminated.
- (4) The S2 plans secondary missions for each available asset.

d. Planning process.

- (1) The task force S2 prepares a detailed R&S plan based on information generated during the IPB process.
- (2) Specific taskings are given to company teams, the scout platoon, GSR sections, and any other element that has a reconnaissance and surveillance capability. As a minimum, the R&S plan should include:
 - (a) **Maneuver units.**
 - Number and location of OPs required, or sectors requiring surveillance.
 - Ambush requirements with locations and effective times.
 - Reaction forces requirements.
 - Obstacles to be protected.
 - Patrol requirements with routes, objectives, and times.
 - (b) **Scouts.**
 - Specific mission (route, zone, or a reconnaissance).
 - Screen location, contact points with adjacent units, and time needed to be established.
 - Attachments with effective time and reporting locations.
 - Subsequent missions.
 - CS and CSS support.
 - (c) **Ground surveillance radars.**
 - Locations, sectors, schedules, and security/support arrangements.
 - Day missions.
 - Subsequent missions.
 - CS and CSS support.
 - (d) **Remote sensors.** Location and emplacement responsibilities.

(e) **Coordinating instructions.**

- Passage instructions, including recognition signals, routes, passage points, and responsible party.
 - Rules of engagement and disengagement.
 - Reporting schedules.
- (3) Intelligence preparation of the battlefield provides the S2 with a guide for effective R&S resources employment. The S2 must use the event template developed during IPB to guide him in where and when to look for the enemy and what units and activities to look for. It also guides him in orienting and directing his R&S resources to the proper area for the needed information. An R&S overlay of the area of operation is necessary to ensure that all areas are properly covered.
- (4) To develop a useful R&S plan, the S2 must adhere to the following elements:
- (a) Commander's guidance.
 - (b) Priorities, terrain and weather, and tactical situation, which determine requirements.
 - (c) Resources, terrain, long-range weather forecast, electronic warfare, operations security, and economy of effort.
- (5) The R&S plan must be developed early in the commander's overall planning process. It must be disseminated early with taskings to promote day coordination, preparation, and reconnaissance. All elements must know where patrols and OPs are located to avoid combat with friendly forces.
- e. **Reporting.** The S2 establishes reporting by an established time schedule. The SALUTE format is used for accurate reporting. Information collected must be quickly disseminated to all elements of the task force and higher headquarters.
- f. **Dissemination of information.** Dissemination within the battalion task force is usually made by personal contacts, oral reports, eavesdropping, and briefings. Dissemination to higher and adjacent units is usually accomplished through reports, summaries, and intelligence estimates and analyses.

3-11. CONCEPT OF OPERATION

The concept of the operation describes a plan for massing firepower by synchronization of fires and maneuver.

a. Maneuver.

- (1) The scheme of maneuver is the central expression of the commander's concept of the operation. The maneuver plan —
 - Designates the main and supporting attacks.
 - Describes the movement and positioning of maneuver forces from the line of departure through actions on the final objective.
 - Directs the task force formation to be used and dictates specific points where the formation changes or company teams move to supporting positions.
 - Provides orientation for the movement or attack using either zones of action, axes of advance, or directions of attack.
 - Designates main attack objectives along with positions and intermediate objectives, if used.
- (2) The scheme of maneuver must be flexible enough to take advantage of developing information. Attack plans will often have two or more initial options; a final choice, based on the latest intelligence, will not be made until just prior to the attack.
 - (a) The scheme of maneuver also addresses actions on the objective and synchronization of the close assault.
 - (b) Actions on the objective are an important aspect of attack planning. The commander must develop a plan to isolate and destroy individual enemy units (usually platoons or smaller) by achieving overwhelming combat power ratios at the decisive point and time. The plan must enable the commander to bring as much combat power to bear as possible by synchronization of maneuver elements and fires. Maneuver units must arrive at their attack by fire positions or commence the assault simultaneously in order to achieve the desired combat power ratios and avoid a "piecemeal" attack. Fires must be planned to enhance combat power ratios. To isolate enemy units from one another, the commander may use direct and indirect fires, including smoke for obscuration, and maneuver to fix units or prevent reinforcement.
 - (c) Reverse planning from actions on the objective is an excellent method for enhancing synchronization of the attack. It serves to clarify the commander's intent and to prevent over-emphasis on movement.

b. Fires.

- (1) Fire support is used to destroy, neutralize, or suppress the enemy, and to provide smoke and illumination that facilitates task force maneuver. Fires support breaching forces, soften enemy forces on the objective before the assault, and suppress the objective area. Fires are shifted as the attack progresses through the enemy defense.
- (2) A task force conducting the brigade main attack will normally have priority of the brigade's direct support artillery battalion, its organic mortars, and aviation supporting it. The commander and his staff develop the scheme of maneuver and supporting fires concurrently. The FSO plans, prepares, distributes, and continually updates the task force fire support plan.
- (3) The FSO recommends and the commander determines those fire support tasks that make the greatest contribution to the attack. The FSO determines priorities and taskings for the battalion mortar platoon in conjunction with the overall fire support plan.
- (4) The priority task for fire support in the attack is the suppression of antiarmor systems that inhibit maneuver.
- (5) Other fire support tasks in the attack include:
 - (a) **Preparation fires.** Preparation fires, including preplanned CAS, can suppress, neutralize, and destroy enemy positions on the objective.
 - (b) **Obscuration and screening fires.** Fires using smoke assist breaching efforts, cover friendly maneuver, and can aid in deception efforts.
 - (c) **Counterbattery fires.** When manual breaching is anticipated, the FSO should coordinate for counterbattery fires, which are planned by higher headquarters.
 - (d) **Illumination fires.** Illuminating fire is always planned for night attacks, but usually held on order of the task force commander.
 - (e) **Priority targets.** Priority targets are normally allocated to weight the main attack.
 - (f) **Fires during the assault.** Assault fires are usually executed in the following sequence:
 - Suppression fires to prevent the enemy from observing and engaging friendly elements and to conceal the movement of companies.

- Concentrated fires to destroy enemy fighting positions near the initial objective.
 - Subsequent fires that concentrate on deeper objectives.
- (g) **Fires during consolidation.** Fires are placed on retreating enemy forces and on deeper positions. Targets are planned on likely enemy counterattack routes or placed on enemy withdrawal routes to force his destruction or capture.

3-12. MAIN AND SUPPORTING ATTACKS

In his concept of the offensive operation, the commander designates a main and any supporting attacks.

a. **Main Attack.**

- (1) The units conducting the main attack are assigned a mission which, when achieved, successfully accomplishes the task force's mission. The main attack secures a key terrain objective or position or destroys an enemy force. Terrain objectives have traditionally been assigned to the elements making the main attack, but attacks by fire to destroy an enemy force may also be the main attacker's mission.
- (2) In a battalion task force attack there is only one main attack. All other elements of the task force support the main attack. The plan of attack must contain provisions for exploiting success whenever it occurs. Commanders must avoid becoming so committed to an initially planned main attack that greater opportunities are neglected.
- (3) Both *main attack* and *main effort* are mechanisms for allowing the concentration and coordination of combat power, but they are not synonymous. The main attack is the task force's main effort at the decisive phase of the attack. The main effort is the focus of combat power at any given time during the attack.
- (4) In planning the scheme of maneuver, the main attack must have sufficient combat power and support to accomplish its mission. Methods of weighing the main attack include —
 - Assigning the main attack to the companies with the highest combat power and bold, aggressive leaders.
 - Allocating additional combat platoons.

- Attaching or placing combat support elements in direct support (such as minerollers and plows, engineers, AVLBs, ADA).
- Providing a priority of combat support (artillery, mortars, engineers, and ADA) and allocating priority targets.
- Positioning overwatch or support-by-fire elements to support.
- Coordinating adjacent unit or attack helicopter support by fire.
- Positioning and assigning planning priorities to the reserve.
- Locating the tactical CP where it can best control the main attack.
- Providing a priority for combat service support.

b. Supporting Attack.

- (1) The supporting attack allows the main attack to be successful. The supporting attack contributes to the success of the main attack by accomplishing one or more of the following:
 - Occupying terrain to support by fire the maneuver of the main attack.
 - Fixing the enemy in position.
 - Deceiving the enemy as to the location of the main attack.
 - Isolating the objective.
- (2) Supporting attacks place fires on the objective, and/or on known or likely supporting enemy positions. Fires are used to destroy as many of the defender's major weapons systems as possible before the main attack reaches the objective. Supporting attacks by fire should come from a different direction than the main attack. This forces the enemy to defend in two directions and avoids the masking of friendly fires as the main attack closes on the objective. Forces used in a support-by-fire role should be considered as potential reserve forces. Plans to move them forward to assist in the final assault or reorganization and continued operation are part of the commander's contingency planning.
- (3) The supporting attack may be by fire and maneuver. In this case, one or more company teams are tasked to secure or seize terrain dominating the main attack's objective. This form of supporting attack is used when conditions will not

allow a supporting attack by fire. The task force seldom can have more than one supporting attack by fire and maneuver because this will weaken the main attack, make the attack difficult to control, and increase the chance of a piecemeal attack. However, it is possible to have one supporting attack by fire and one by fire and maneuver.

3-13. COMPANY TEAM MISSIONS IN THE ATTACK

Within the main or supporting attack the task force commander assigns companies and company teams one of four basic missions to support the task force scheme of maneuver.

- a. **Attack to Seize/Secure a Terrain Objective.** If the mission is to seize an objective, the company must clear it of enemy. Securing means not only gaining possession of the objective but deploying in a manner that prevents its destruction or loss to enemy action. The commander must clearly state the purpose to be achieved by seizing or securing the objective.
- b. **Overwatch.** A unit assigned an overwatch mission supports the movement of other elements by placing direct fire or adjusting indirect fire on enemy forces that can engage the supported unit. Designation of the element to be overwatched and fire control measures must be assigned. Range of enemy antiarmor systems normally require frequent repositioning by the overwatch element. The commander may designate series of overwatch positions or may specify positioning instructions for the overwatch element. Overwatch positions are usually shown graphically as checkpoints.
- c. **Attack by Fire.** This mission requires engaging an enemy force with direct fire to destroy, fix, or suppress it. Positions and sectors of fire or other fire control measures can be assigned.
- d. **Reserve.** The task force commander determines the size, composition, and location of his reserve. The commander prioritizes missions for planning and coordination, based on likely contingencies.

3-14. RESERVE CONSIDERATIONS

A task force reserve is designated whenever possible. The reserve is an uncommitted force, used during the operation at the critical place and time to ensure mission success. The reserve is assigned "be prepared" missions, in priority order for planning.

- a. **Size.** A vague enemy situation, such as in a movement to contact, requires a strong reserve, whereas more developed information on the enemy, such as in a deliberate attack, could reduce the need for a reserve.
- b. **Composition.** The reserve is normally a company team to ensure a flexible enough organization to react to various contingencies. It is often balanced or tank-heavy, but the exact composition is dependent on the factors of METT-T. Because an antiarmor company cannot close with the enemy, it should not be the sole reserve.
- c. **Location.** The reserve follows the main attack at a distance sufficient to keep it from interfering with the movement of the lead company teams and to maintain its freedom of maneuver. The reserve maintains the flexibility to shift to a supporting attack if the main effort is changed.
- d. **Commitment.** The reserve commander must understand the commander's intent, particularly the decision points for commitment. The reserve company commander must remain updated on the situation. The decision to commit the reserve is critical. The task force commander reconstitutes or redesignates the reserve as soon as possible. The reserve is used to:
 - Maintain the momentum of the attack and exploit success.
 - Defeat or block counterattacks.
 - Hold key terrain seized by the attacking force.
 - Fix a bypassed force.
 - Assume the mission of a committed unit.

3-15. SYNCHRONIZATION OF OFFENSIVE OPERATIONS

The commander and staff synchronize and integrate all combat, combat support, and combat service support assets organic and available to the battalion task force. Each element has primary offensive employment considerations that are explained in this section. Employment considerations that vary from those stated here are addressed specifically under the type of operation.

a. Maneuver.

- (1) **Tanks.** With their combination of mobility, firepower, and armor protection, tanks are the primary mounted assault element of the task force. Tanks are used to weight the main attack. Tanks may be assigned support-by-fire missions when

their direct fires are needed to support assaults, or if obstacles initially prevent them from assaulting the enemy. Tanks are employed in at least platoon strength. When a reserve is formed, tanks are normally allocated to it.

- (2) **Infantry.** Mounted infantry is used in the main attack when enemy antiarmor fires are weak or have been suppressed. Because of vulnerability to antitank fires, BFVs are used to overwatch tanks or dismounted infantry when facing more than light antiarmor resistance. Dismounted infantry may lead by infiltration to clear obstacles or key enemy positions and disrupt the enemy's defense. Dismounted infantry can maneuver on untrafficable terrain to attack from an unexpected direction to permit the resumption of mounted combat. Dismounted infantry may assault with tanks against strong enemy resistance to protect the tanks from close-range antiarmor weapons. Infantry can also be used extensively in reconnaissance and counterreconnaissance roles.
- (3) **Antiarmor company.** In the offense, the antiarmor company maneuvers to provide overwatch and support-by-fire. Security and economy of force missions are also appropriate.
- (4) **Scouts.** During the offense, the scout platoon is employed in a security or reconnaissance role for the moving force. The primary mission for the scout platoon in the offense is reconnaissance.
- (5) **Attack helicopters.** Attack helicopters may be employed by brigade to provide overwatch, to cover areas ground units cannot cover, or to rapidly mass to provide increased antitank capability. When this occurs, coordination is required to ensure synchronized application of combat power.

b. Fire Support.

- (1) **Field artillery.** Field artillery is used to suppress, neutralize, or destroy enemy direct fire weapons and to obscure task force maneuver. Fires support breaching operations, soften enemy forces on the objective before the assault, and suppress the objective area. Field artillery and mortars are positioned to shift as the attack progresses. The commander and his staff develop the scheme of maneuver and supporting fires concurrently. The FSO plans, prepares, distributes, and continually updates the task force fire support plan. Counterbattery fires are planned and executed at division. Usually, the priority task for fire support in the attack is

the suppression of antitank systems that inhibit maneuver. As units maneuver, fires must be shifted to ensure adequate suppression. Company FSOs are tasked to call for suppressive fires, and adjust them. The battalion FSO and FSE monitor calls for fire to ensure that unnecessary, unsafe, or excessive fires are not requested.

- (2) **Mortars.** The mortar platoon operates as a platoon or as two firing sections. Because of range limitations, mortars must be emplaced well forward to provide effective fire support. This frequently puts mortars with companies in offensive operations. The mortar platoon leader is responsible for continuous coordination with the company in whose area he is positioned or with whom he is moving. The normal mission of the platoon in the offense is to provide fire support to the entire task force (general support) under the direction of the FSO. During the planning phase and subsequent coordination, the FSO determines the targets that are to be engaged by mortars. The FSE monitors the mortar FDC nets. In fast-moving offensive operations where there is a need for decentralized control, the mortar platoon or a mortar section may be given a direct support mission or attached to one company. In this case, the mortar element is on the net of the supported company and moves and positions to support that element as directed by the company FIST.
- (3) **Air Force.** Close air support (CAS) represents air action against targets close to battalion forces. Each mission must be carefully controlled and requires detailed integration with the fire and movement of those forces. CAS missions may be either preplanned or immediate. When available, preplanned missions are most frequently used as preparation fires prior to deliberate attack. Immediate requests are filled by aircraft on ground alert or by diverting aircraft from other missions. Requests for immediate CAS go directly from the task force FAC through Air Force channels and are processed unless intermediate monitoring headquarters disapprove the request within 5 minutes. Immediate missions will normally take more than 30 minutes to arrive on station.

c. **Intelligence.**

- (1) **Ground surveillance radar.** During the offense, GSR is employed with reconnaissance and security elements on an exposed flank or to provide additional observation and security. They are required to provide continuous surveillance. Radar should be kept as far forward as the tactical situation and terrain will permit.

(2) **Army aviation.** Available scout and attack helicopters can also be employed in support of the intelligence collection effort.

d. **Air Defense Artillery.** Whenever possible, ADA elements supporting the offense are kept under the centralized control of the platoon leader. Centralized control allows better coordination of ADA support and provides excellent coverage at choke points. Attaching ADA assets is often appropriate in fast-moving offensive operations to get coverage well forward, and to ensure area coverage.

e. **Mobility, Countermobility, Survivability.**

(1) **Engineers.** Priority of engineers in offensive operations is to mobility.

(a) **Mobility.** Engineers seek to improve movement of maneuver forces and critical supplies by reducing or eliminating obstacles, breaching minefield, and improving routes for maneuver and supply. The brigade commander normally attaches at least an engineer platoon to the task force and augments it with additional assets depending on the task force mission. Combat engineer assets are normally located well forward in the attack formation to provide responsive support.

(b) **Countermobility.** Engineers plan for the use of FASCAM to be delivered by the field artillery and Air Force. Obstacles may be used to enhance flank security and prevent enemy reinforcement. Countermobility support involves obstacle construction to delay, canalize, disrupt, or kill the enemy. Obstacles should increase target acquisition time and, therefore, the effectiveness of direct and indirect fire weapons systems.

(2) **NBC.**

(a) **Mobility/Countermobility.** NBC operations in the offense concentrate initially on countermobility plans. Chapter 6 discusses the use of smoke in offensive operations.

(b) **Survivability.** Mission-oriented protection posture (MOPP) levels are established based on enemy NBC capabilities, workload, and weather.

f. **Combat Service Support.**

(1) **Combat trains.** During offensive operations, the task force combat trains CP is the focal point of combat service support

for the unit. CSS functions are performed as far forward as the tactical situation permits. Class III, V, VII, and IX and replacements are “pushed” forward to the companies at the logistical release points (LRPs). The task force combat trains move with the main body. They stay at least a terrain feature behind the maneuver forces during attacks and assaults.

- (2) **Support platoon.** During the offense, the support platoon priority should be providing resupply of Class III and V to maintain the momentum of the attack.
- (3) **Medical platoon.** Priority of effort for the medical platoon is to perform rapid triage and evacuation of casualties. The aid stations should locate in areas easily accessible to wheeled vehicles.
- (4) **Maintenance platoon.** The maintenance platoon must quickly repair or evacuate combat vehicles to the main supply routes. The concept of fix-forward is imperative in order to maintain sufficient combat systems to maintain the momentum of the battle.

3-16. PLANNING CONSIDERATIONS FOR NIGHT ATTACKS

Limited visibility attacks are conducted to achieve surprise and capitalize on our night vision capabilities. Planning must begin as early as possible to allow daytime preparation for the night attack. Sleep plans are adjusted; commanders make every effort to ensure that leaders are rested before night attacks. The plan must be simple and must facilitate execution.

- a. Night attacks are planned basically the same as daylight attacks, and many principles and techniques for night attack also apply to daytime limited visibility attacks.
- b. The task force normally conducts night attacks with dismounted infantry. Light infantry can infiltrate during limited visibility to support a link-up and daylight attack by mechanized units or to destroy selected targets. During exploitations, pursuits, and attacks against known enemy weak positions, the task force attacks mounted at night.
- c. The dismounted night attack is conducted in four phases: preparation, movement, assault, and consolidation and reorganization.
 - (1) **Preparation.** This phase includes all reconnaissance activities. The most critical preparation for the attack is the

positioning of the support elements that generate suppressive fires at the point of attack.

- (2) **Movement.** The dismounted elements of the task force move by stealth from the point of departure to an assault position. The order of movement should be the support element followed by the breaching element, then the assault element. The task force can close with the enemy at night by taking advantage of the enemy's inability to acquire and engage targets at long range, and of reduced mutual support between his positions.
 - (3) **Assault.** The support element establishes overwatch positions on the flanks of the point where the enemy's protective barriers (minefield) will be breached. Once this is completed, the breach element positions itself at the edge of the minefield.
 - (a) The breach element marks the breached lane and provides guides to the assault elements, which move quickly to exploit the breach. The support force and heavy mortars fire into the interior of the position to prevent the enemy from repositioning forces.
 - (b) The assault element must be able to control fires of the close overwatch forces to keep fires forward of the assault element. Planning should include visible light signals to identify assault elements and to lift or shift fires.
 - (4) **Consolidation and reorganization.** The consolidation and reorganization phase is basically the same for a night attack as for a daylight attack, but must be planned in greater detail. The plan should include the following:
 - Contact points between units and recognition signals.
 - Provisions for guides to lead support elements through obstacles to final consolidation positions.
 - A route for each unit or a priority of movement if multiple routes are not available.
 - A limit of advance.
 - Repositioning of air defense assets.
- d. Task force SOPs and orders must make provisions for marking vehicles and positions at night. Plans and rehearsals must include redundant communications systems. Although radio is the primary means of communication in the attack, the commander must stress increased use of other means. Consideration should be given to the following alternative systems of communication:

- Wire.
 - Audible signals.
 - Visual signals.
 - Messenger.
- e. Night attack control measures are usually more restrictive than those used during daylight. All control measures for a night attack must be easily identifiable on the ground. The commander should impose only those measures necessary to exercise control. The following control measures in planning night attacks are the minimum necessary to ensure success:
- Attack position.
 - Point of departure.
 - Direction of attack.
 - Release points.
 - Assault position.
 - Probable line of deployment (PLD).
 - Objective.
 - Limit of advance.
- f. Leaders at all levels must be well forward to maintain orientation while moving in the attack. Even with improved night vision devices (NVD) and thermal sights, night navigation is still difficult. The following can be used to assist navigation:
- Identifiable terrain.
 - Guides.
 - Visible light markers.
 - Flares and illumination rounds.
 - Compass and odometer.
 - Ground surveillance radar.
- g. Fire support considerations are as follows.
- (1) **Direct fire.** Units must remain aware of adjacent unit positions, as the potential for fratricide increases during limited visibility. Detailed and precise fire control measures must be established and understood, especially all signals for lifting and shifting supporting fires.
 - (2) **Indirect fire.** Fires should be planned to suppress and isolate the objective, and provide illumination and

obscuration. Initially, limited visibility attacks should be nonilluminated. Although the task force has the advantage of seeing in the dark with its NVDs and target acquisition systems, illumination is planned so that it is available when required.

3-17. BYPASS PLANNING CONSIDERATIONS

In a bypass operation, the commander deliberately avoids offensive combat with an enemy force or position, thus avoiding dissipation or diversion of combat power to efforts other than accomplishment of the mission. Bypass operations will occur during the movement to contact, deliberate attack, exploitation, and pursuit. The decision to bypass is based on —

- The requirement to maintain momentum and aggressive action.
 - The commander's knowledge of enemy strength.
 - The degree to which the bypassed enemy can interfere with the advance.
 - The general state of the enemy force. If enemy resistance is crumbling, greater risks can be taken.
- a. Authority to bypass is not normally delegated below task force level. Orders will limit the size of the enemy force that can be bypassed without the authority of the next higher commander. Regardless of the level to which authority has been granted, the commander conducting the bypass immediately notifies the next higher commander of his intention. The bypassed enemy must be kept under observation, and troops must be detailed for this task. At no time must the enemy force be able to interfere with the bypassing units.
 - b. One or both of the following bypass techniques may be employed:
 - Avoid the enemy and bypass.
 - Fix the enemy by fire and bypass.
 - c. The mission to bypass implies that the task force must fix the enemy with part of the maneuver elements and bypass with the balance of the force (see Figure 3-12, page 3-36).
 - (1) The TF commander will normally direct a unit to fix and maintain contact with the enemy until relieved by follow-and-support forces. This may require the fixing force to be reinforced with combat support elements. The fixing force commander coordinates with the follow-and-support force commander as early as possible and provides him with all

available information about the enemy and terrain. Following this, the fixing force quickly rejoins the main force.

- (2) Occasionally, the fixing force may be directed to break contact with the enemy after the bypassing force has completed the bypass. This will occur when the bypassing force has no requirement to maintain an uninterrupted logistics flow, such as in a raid. In this case, the fixing force blocks the enemy, employing defensive, delaying, limited offensive action, and all available fire support, until ordered to rejoin the bypassing force.

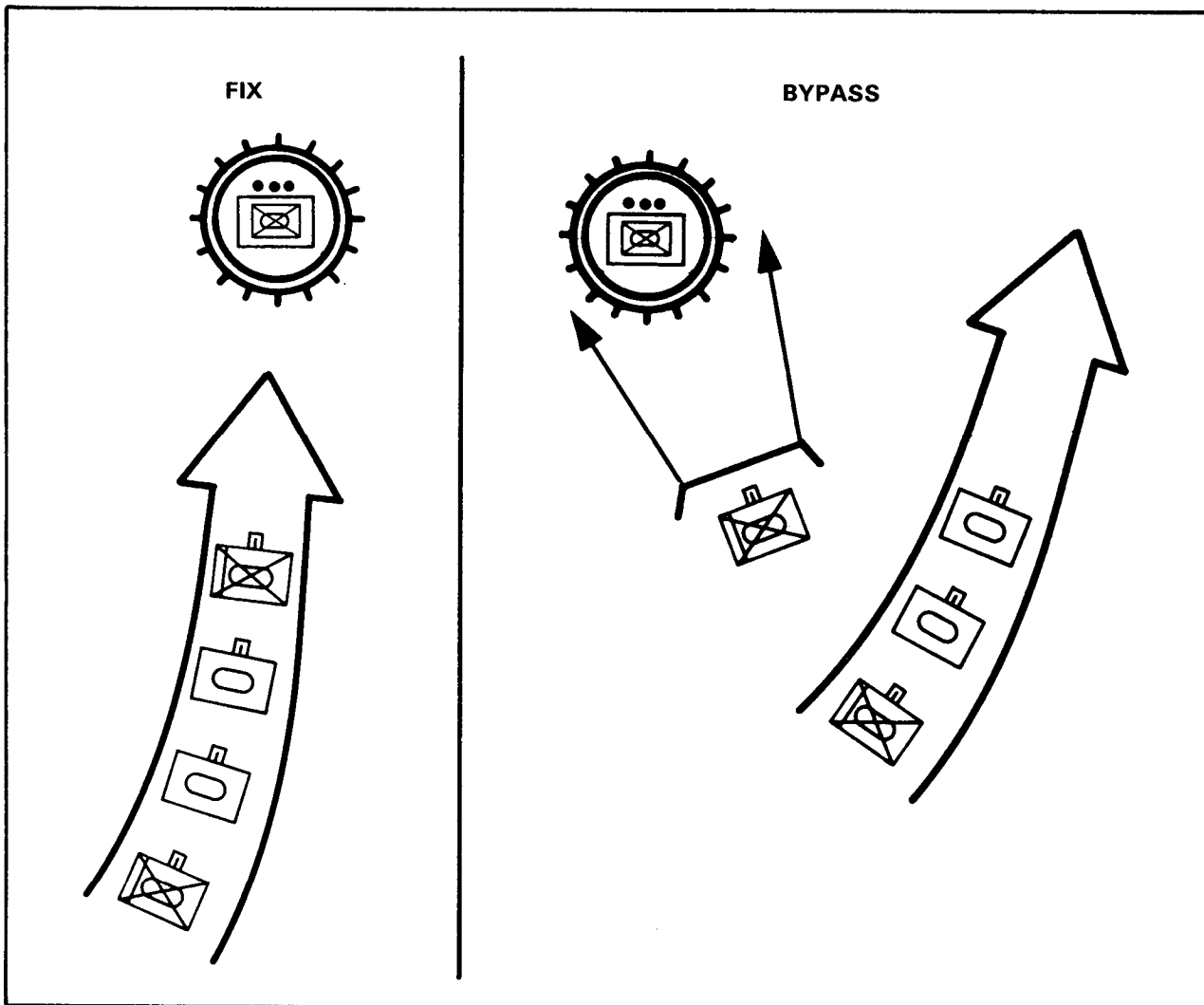

Figure 3-12. Task force conducting a fix and bypass.

3-18. ASSAULTS AND ACTIONS ON THE OBJECTIVE

The assault is the overrunning and seizing of an occupied enemy position. The goal of any assault is to destroy the enemy as rapidly as possible with minimum friendly casualties, while physically overrunning or occupying the position.

a. Considerations.

- (1) Assaults may be mounted or dismounted. Generally, mounted assaults permit a more rapid operation, while dismounted infantry slows the operation but adds a greater degree of security. The commander determines if, when, and where infantry dismounts based on his analysis of the factors of METT-T and the degree of risk he is willing to accept.
- (2) In any assault, the objective must first be isolated by direct and indirect fires.
- (3) The unit making the assault is the task force's main effort. As such, it receives priority of support.

b. Mounted Assaults.

- (1) In mounted assaults, infantry remain mounted during the assault or tanks assault without infantry. This allows the greatest speed and shock action and provides the best protection for infantry against small-arms and indirect fire.
- (2) Mounted assaults are conducted against weak or hastily prepared enemy positions or in meeting engagements.
- (3) In a mounted assault, tanks lead. If the objective is to be cleared, infantry dismounts and sweeps the objective to clear any remaining pockets of resistance.
- (4) A major advantage of mounted assault is the ability to move onto the objective closely following variable time (VT) fuzed mortar and artillery fires and smoke. Using such fires, the assault is conducted with tanks and BFVs buttoned up. Dismounted infantry initiates clearing operations immediately after the VT fires are lifted or shifted.

c. **Dismounted Assaults.** To maintain speed, maximize protection against small-arms and indirect fires, and conserve the strength of the soldiers, infantry moves mounted as close to the objective as possible. Dismounted assaults are usually conducted when any of the following conditions apply:

- The enemy is in prepared positions.

- The enemy possesses a strong antiarmor capability.
- Tanks are not available to lead the assault.
- Terrain favors dismounted operations.
- Obstacles prevent maneuver across the objective.
- Stealth is required to close on the objective.
- A mounted assault stalls on or short of the objective.

3-19. CONSOLIDATION AND REORGANIZATION

Actions on the objective continue from the assault into consolidation and reorganization. The task force may not be required to consolidate and reorganize, but may continue to attack or to exploit as directed by brigade.

- a. **Consolidation.** Consolidation of the objective is the elimination of any remaining resistance on the objective and preparing the position to be able to withstand counterattack. Consolidation must be planned and coordinated before the attack. The resulting task force positioning must facilitate subsequent missions. An attacking unit must also disperse to avoid becoming a lucrative target. The following points are normal phases of consolidation and reorganization of an objective:
 - (1) **Eliminate enemy resistance.** The task force ensures that the objective is cleared by destroying, capturing, or forcing withdrawal of all enemy vehicles and personnel.
 - (2) **Defend.** Having cleared their objectives, companies occupy hasty fighting positions in preparation for an enemy counterattack. Hasty protective minefield are coordinated and emplaced. Attacking elements DO NOT occupy vacated enemy positions, as these positions may be targeted by the enemy. Armor and antiarmor platoons are positioned to cover likely avenues of mounted approach. Mechanized infantry dismount and orient along likely avenues of dismounted and mounted infantry approach.
 - (3) **Establish security.** Security is established concurrently with the occupation of hasty defensive positions. Each company positions OPs to monitor the most likely avenues of enemy approach. Patrolling is initiated as early as possible.
 - (4) **Plan fires.** Once in position, company commanders and platoon leaders verify task force TRPs and designate sectors

- of fire to control direct fires. Indirect fires are planned on likely approaches and beyond, as necessary, to facilitate future operations.
- (5) **Conduct reconnaissance.** The scout platoon will screen the task force along the most dangerous enemy avenue of approach.
 - (6) **Prepare for contingency missions.** The task force commander and staff continue IPB and troop-leading procedures in preparation for “on-order” and “be prepared” missions during consolidation.
- b. **Reorganization.** Reorganization includes all measures taken to maintain the combat effectiveness of the unit. Reorganization includes —
- Replacing key personnel. Replacements are brought forward by LOGPAC resupply.
 - Evacuating or recovering casualties, prisoners of war, and damaged equipment.
 - Redistributing supplies, ammunition, and equipment within the unit as necessary. Basic loads of ammunition and fuel, and prescribed loads of repair parts are replenished by LOGPACs.

3-20. OFFENSIVE CONTROL MEASURES

Control measures are used with specific missions to subordinate units to define the scheme of maneuver. Sufficient control measures are used to coordinate the efforts of the task force and to allow the task force commander to rapidly give FRAGOs to change the plan during the attack. Normally, the least restrictive measures possible are used. See FM 101-5-1 for a complete discussion of control measures.

a. Objective.

- (1) The task force commander assigns terrain objectives if the task force mission is to **seize** or **secure** a terrain feature. If the task force mission is **destruction** of an enemy force, he assigns objectives for orientation and control.
- (2) The task force commander may assign **intermediate objectives** to company teams when a piece of terrain is critical to the scheme of maneuver.
- (3) Objectives should be on easily identified terrain features and should facilitate consolidation, reorganization, and continuation of the mission.

b. Zone of Action.

- (1) Task forces are normally assigned zones of action. A zone of action is defined by boundaries and is the unit's area of operation.
 - (2) Zones of action are assigned when the mission of units requires a clear delineation of areas of responsibility. Boundaries do not require a subordinate unit to clear the zone of enemy forces unless so specified in the operation order. If units are authorized to bypass enemy forces, the commander must give guidance as to the size force that can be bypassed. If enemy units are bypassed, brigade will destroy the bypassed enemy force with a follow-and-support unit, with the brigade reserve, or by fire. However, any enemy force that can interfere with the task force's or brigade's maneuver must be fixed, if bypassed. Even small, armored forces represent such a danger, while larger dismounted forces might not. Brigade must be informed of all bypassed enemy units. Normally, a bypassed enemy force is fixed in place by part of the task force until another unit arrives to relieve the fixing force.
 - (3) The task force commander is responsible for all operations in his assigned zone except those specifically assumed by higher headquarters. He is free to maneuver his units and to fire within the zone. The commander is responsible for locating and destroying the enemy in his zone consistent with the accomplishment of his mission and to the extent necessary to provide for the security of his command. Task forces seldom assign zones of action to subordinate units.
 - (4) A zone of action should –
 - Provide adequate maneuver space to the subordinate unit.
 - Clearly assign key terrain features and avenues of approach to them.
 - Extend beyond the objective for fire support coordination.
- c. **Axis of Advance.** An axis of advance is used to indicate the general direction of movement of a unit. Commanders must ensure that deviation from the assigned axis of advance does not interfere with the movement or fires of adjacent units. When more than one axis of advance is used, one is designated as the main attack.
- d. **Direction of Attack.** A direction of attack is a restrictive control measure used when the task force commander needs to designate a **specific** direction of attack or to tightly control a plan of attack. A unit must employ the bulk of its combat power along the

assigned direction of attack. The unit cannot deviate from it except to maneuver against enemy forces interfering with the advance. A direction of attack —

- Follows well-defined terrain features such as trails.
 - Is used principally in night attacks and counterattacks.
- e. **Line of Departure.** An LD is used to coordinate the commitment of attacking units or screening elements at a specific time. The LD should be easily recognized on the ground and on the map and should be generally perpendicular to the direction of attack.
- f. **Attack Positions.** Attack positions are the last covered and concealed positions passed through before crossing the LD. Attack positions are used by company teams to coordinate, organize, and/or resupply before crossing the LD. When the attack involves a passage of lines, the attack position should be to the rear of the elements in contact. This attack position must be coordinated with the unit in contact.
- g. **Assault Position.** Assault positions are located between the line of departure and the objective where forces deploy for the assault of the objective. Ideally, they are the last covered and concealed positions before the objective.
- h. **Final Coordination Line.** The FCL is a line close to the enemy position used to coordinate the lifting and shifting of supporting fires with the final deployment of the task force. It should be recognizable on the ground. It is **not** a fire support coordination measure.
- i. **Phase Line.** A phase line extends across the zone of action of the task force. Phase lines are established to control and coordinate maneuver, to coordinate fires with maneuver, and to assist in executing contingency plans.
- j. **Overwatch Position.** Overwatch positions are usually indicated graphically as checkpoints.
- k. **Attack-by-Fire Position.** An attack-by-fire position is used to designate the position from which direct fires are placed on an objective or into an engagement area (see Figure 3-13, page 3-42).
- l. **Infiltration Lane.** When stealth is required to move through an area occupied by the enemy, infiltration lanes may be used.
- m. **Limit of Advance.** The limit of advance is the control measure used to stop the forward progress of attacking units; it does **not** restrict fires.

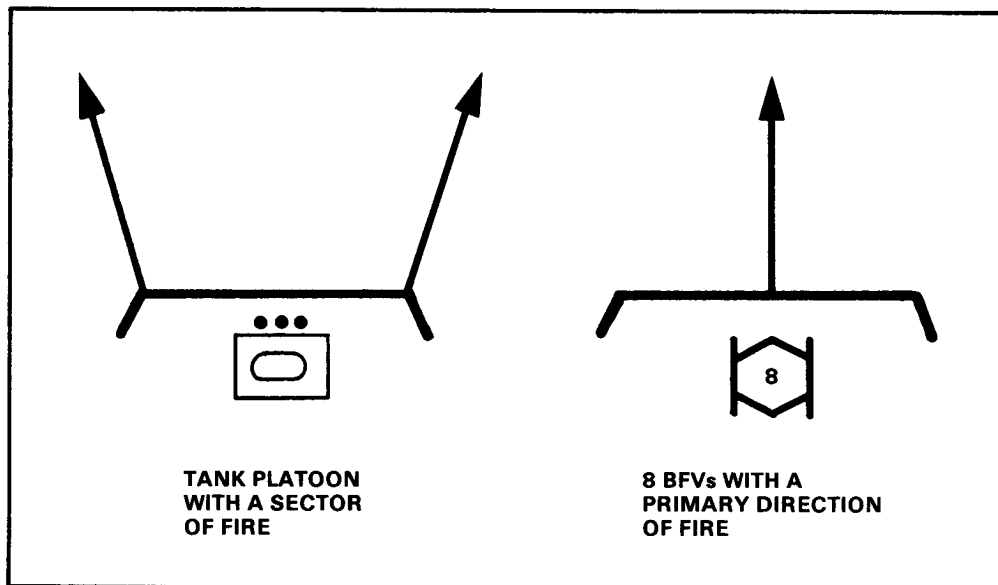

Figure 3-13. Attack-by-fire position symbol.

- n. **Checkpoints.** Checkpoints provide the commander the capability of rapidly shifting fires and reorienting maneuver forces by using recognizable terrain features.
- o. **Techniques for Fire Control While Moving.** Direct fires may be controlled on the move by marking a target with white phosphorus (WP) or tracers, and using it as a hasty TRP. Another expedient method to control fires is to use the clock system, with 12 o'clock being the general direction of advance.

Section IV. CONDUCTING ATTACKS

3-21. MOVEMENT TO CONTACT

- a. The battalion task force conducts a movement to contact to make or regain contact with the enemy and to develop the situation. Task forces conduct movement to contact independently or as part of a larger force (see Figure 3-14). The battalion task force will normally be given a movement to contact mission as the lead element of a brigade attack, or as a counterattack element of a brigade or division. Movement to contact terminates with the occupation of an assigned objective or when enemy resistance requires the battalion to deploy and conduct an attack to continue forward movement.

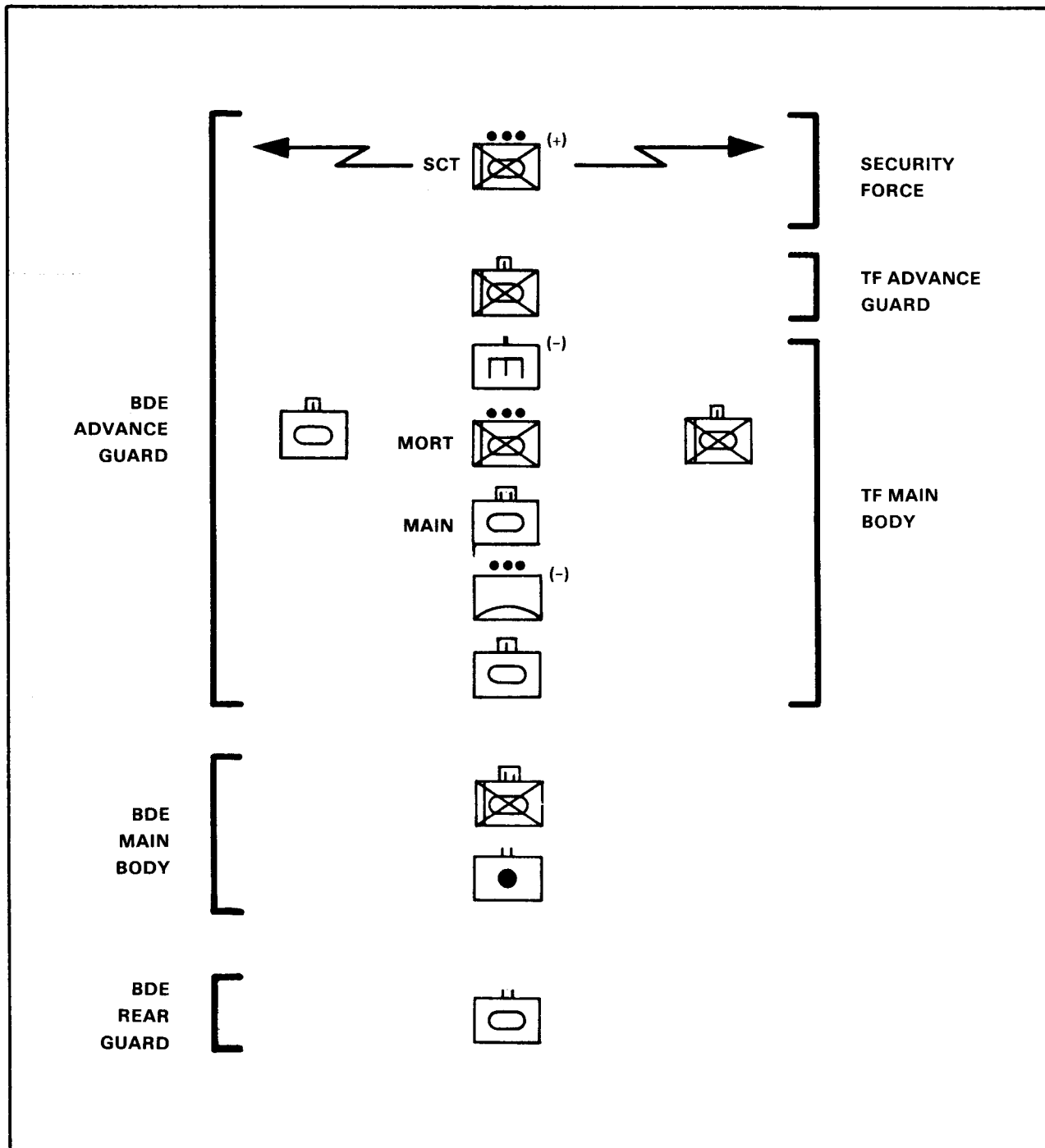

Figure 3-14. Battalion Task Force movement to contact as part of a brigade attack.

- b. A task force given a movement to contact mission is assigned a zone of action or an axis of advance and an objective at a depth sufficient to ensure contact with the enemy. Movement to contact is conducted in a manner that allows the task force to maneuver to fully develop the situation, maintain freedom of action, and, if possible, defeat the enemy once contact is made.
- c. Key planning considerations for the movement to contact are:
 - (1) **Movement.** Task force movement is oriented on the objective and along any assigned axis of advance. The task force moves consistent with the following factors:
 - Speed required by brigade.
 - Available avenues of approach.
 - Requirements to maintain mutual support between maneuver units, security, and fire support to the security force.
 - Making contact with the smallest element possible.
 - Reacting to contact faster than the enemy.
 - (2) **Task organization.** The task force is organized with a security force, advance guard, main body, and flank and rear guards.
 - (a) **Security force.**
 - The security force is normally established with the battalion scout platoon. Engineers and FOs are attached to the scout platoon and the security force as necessary. Normally, the screening force has initial priority of indirect fires. The mission of the security force is to determine the size, activity, location, and depth of the enemy force. Decisive engagement is avoided but, once found, the enemy must be kept under surveillance and his activity reported.
 - The security force is assigned area reconnaissance missions. It **must** cover the frontage of the task force axis of advance.
 - The security force must be far enough ahead of the advance guard (usually 2 to 6 kilometers) to provide adequate warning and sufficient space for them to maneuver. However, the security force must not be so far ahead that the advance guard cannot rapidly assist it in disengaging from the enemy should that become necessary. The advance guard keys its movement on the movement of the security force.

- When the enemy force is discovered, the security force calls for and adjusts fires on the enemy. Once the lead elements close on the enemy, the screening force places fires on the enemy's positions in depth or on forces maneuvering against the main body.

(b) Advance guard.

- The advance guard for a task force movement to contact is usually a company team. Its composition is METT-T dependent. In open terrain, a tank-heavy team is preferred. At night, a mechanized-infantry-heavy team is preferred. The engineers follow or are attached to the lead elements. When a task force is moving in parallel columns, the two lead companies are task organized accordingly. The mission of the advance guard is to provide security for the main body and facilitate its uninterrupted advance. This is done by rapidly developing the situation upon encountering the enemy's force, destroying reconnaissance or delaying enemy forces, and reducing obstacles.
- The advance guard is the task force commander's initial main effort. Priority of fires is shifted to the advance guard once it is committed.
- In planning the movement to contact, each contingency operation should revolve around the actions of the advance guard. The lead elements must be well trained and well rehearsed on battle drills, especially those involving obstacle reductions and actions on contact.

(c) Main body.

- The main body remains 1 to 2 kilometers behind the advance guard lead element, keying its movement to that of the advance guard. The main body remains close to the advance guard to provide responsive support when it is committed.
- The main body of the task force contains the bulk of the combat elements and is arrayed to achieve all-round security. It is flexible enough to maneuver rapidly to a decisive point on the battlefield to destroy the enemy. The tactical CP follows the advance guard; the main CP moves behind the lead element of the main body.
- The use of standard formations and battle drills allows the battalion commander to rapidly shift combat

power on the battlefield. Companies employ the appropriate movement techniques within the battalion formation.

(d) **Flank and rear guards.**

- Flank security is normally accomplished with platoon-size elements from one or more of the companies in the main body providing a flank guard under company control. These elements are located at a distance from the main body that would allow the task force time and space to maneuver to either flank. In open terrain, this distance may extend from 2 to 3 kilometers. Indirect fires are planned on major flank approaches to enhance security.
- The trailing company of the main body provides a rear guard to protect the task force rear.
- Security is also attained by rapid forward movement which gives the enemy less time to react or to reposition forces to attack the task force.

(3) **Integration of combat support and combat service support elements.**

- (a) **Antiarmor.** Antiarmor platoons are used as flank and rear security or are positioned to overwatch the advance guard.
- (b) **Scout platoons.** The scout platoon is normally the battalion task force security force. When not performing as the security force, the scout platoon is employed in a flank screen or required to maintain contact with an adjacent battalion task force.
- (c) **Field artillery.** Priority targets and FASCAM are allocated to the security force and advance guard. Direct support field artillery is provided by the brigade or division. Field artillery units are positioned by brigade to provide continuous indirect fires for the moving battalion task force.
- (d) **Mortars.** The task force mortars are placed under the operational control of the advance guard to provide responsive fires and smoke to support initial actions on contact.
- (e) **Air Force.** CAS, if available, is employed to interdict enemy counterattack forces or destroy defensive positions.

- (f) **GSR.** GSRs are employed on flank avenues of approach to provide early warning to the battalion task force. If movement occurs during limited visibility, GSRs may be used to guide the advance guard and elements of the main body toward the objective.
- (g) **Air defense artillery.** ADA assets are generally employed to provide area coverage for the task force, and to cover movement through restricted areas. However, some ADA assets may be placed in direct support of the advance guard.
- (h) **Engineers.** Priority of engineer support is to mobility. Elements of the supporting engineer unit are employed with the security force to reconnoiter obstacles. Engineers travel with the advance guard to assist in mobility of the advance guard and main body. AVLBs move to the rear of the advance guard to be in position to provide responsive support to the maneuver of the main body. FASCAM is planned to support the security force and the advance guard.
- (i) **Combat trains.** The task force may form unit trains for an extended movement to contact. Otherwise, it forms into echeloned combat and field trains. The combat or unit trains move as part of the task force main body. The combat trains consist of the command post, support platoon, and medical platoon. All other assets not essential for tactical support are located at the field trains.
- (j) **Support platoon.** The task force support platoon moves with the main body during the movement to contact. The support platoon priority of support is to Class III and Class V. Communications are maintained with the battalion combat trains CP and field trains CP to monitor the fight and responsively switch support to a redesignated main effort.
- (k) **Medical platoon.** Priority of effort of the medical platoon is to the evacuation of wounded.
- (l) **Maintenance platoon.** The maintenance platoon detaches a trail party to the battalion task force rear guard. The trail party recovers or repairs damaged equipment or coordinates its collection with the FSB. All other maintenance assets locate with the field trains and prepare to provide support once the situation allows.

3-22. MEETING ENGAGEMENT AND ACTIONS ON CONTACT

The meeting engagement is normally the result of a movement to contact. A meeting engagement is the initial contact that occurs when a task force not completely deployed for battle encounters an enemy force on which little information is known. The enemy may be moving or stationary. The task force commander wargames contingencies to define how much initiative he will allow subordinate commanders in reacting to a meeting engagement. The goal, once contact is made, is to quickly and decisively overcome the enemy before he can effectively react. To do so, the battalion commander keeps his force in a position to maneuver immediately to the contact, gather and report information, and issue instructions.

- a. The security force makes the initial contact. They must quickly determine the size and activity of the enemy force and avoid being fixed or destroyed — if possible, the security force avoids detection.
- b. If the enemy is moving, the screening force determines the direction of movement and the size and composition of the force. The screening force FO places fire on the lead enemy companies. Speed of decision and execution is critical when the enemy is moving. When two forces converge, threat doctrine calls for his force to immediately conduct a hasty attack from the line of march and attempt envelopment.
- c. If the enemy is stationary, the security force determines if enemy positions are prepared and reinforced by obstacles or minefield. The security force attempts to identify individual antitank weapon positions, and the enemy's flanks and gaps in his positions.
- d. The advance guard quickly moves to overpower and destroy platoon-size and smaller security forces and combat outposts. Larger forces normally will require deployment of the main body. The advance guard protects the main body and allows the task force the freedom to maneuver by fixing larger than platoon-size enemy forces.
- e. In developing the situation, the advance guard commander maintains pressure on the enemy by fire and maneuver. He probes and conducts a vigorous reconnaissance of the enemy's flanks to determine his exact location, composition, and disposition. The information gained by the security force and advance guard is used to develop a task force plan of action.
- f. The task force commander has several action on contact options based on the enemy situation and his mission.

- (1) **Bypass.** If rapid forward movement is required, and if bypass of enemy forces has been authorized by the brigade commander, the task force can bypass. If the size and mobility of the bypassed force represents a threat, the enemy force must be fixed or contained until released by brigade follow-on forces or reserve.
- (2) **Hasty ambush.** Ambush is effective against a moving force that is not aware of the presence of the task force. Instead of immediately opening fire, the advance guard (and possibly the entire task force) moves into hasty firing positions oriented on an engagement area. When most of the enemy formation is in the engagement area, the enemy is attacked by massed fires and maneuver.
- (3) **Hasty attack.** Task force planning and SOP reactions to contact define the criteria for conducting hasty attacks or for slowing the advance to prepare a deliberate attack. Preparations for a deliberate attack are initiated when the enemy is in strong, prepared positions with extensive obstacles, bypass is not authorized, and a hasty attack is not possible or has failed.
- (4) **Defense.** The task force may defend after making contact with a stronger force or as a prelude to a deliberate attack. The task force defends initially from hasty positions, employing spoiling or counterattacks as possible to slow and disrupt the enemy advance.

3-23. HASTY ATTACK

The hasty attack differs from the deliberate attack only in the amount of time allowed for planning and preparation. The hasty attack is conducted either as a result of a meeting engagement or when bypass has not been authorized and the enemy force is in a vulnerable (unprepared or unaware) position. Hasty attacks are initiated and controlled with FRAGOs. There are two categories of hasty attack depending on the disposition of the enemy:

- An attack against a moving enemy force.
- An attack against a stationary enemy force.

a. Attack Against a Moving Force.

- (1) When two opposing forces converge, the side that wins is normally the one that acts fastest and maneuvers to positions of advantage against the opponent's flank. Task force contingency planning and SOP reactions to contact facilitate

the execution of a hasty attack. The advance guard attacks or defends, depending on the size and disposition of the enemy force. The task force commander maneuvers trailing or adjacent teams against the enemy's flank or rear, while attacking by fire and interdicting enemy units attempting to do the same (see Figure 3-15).

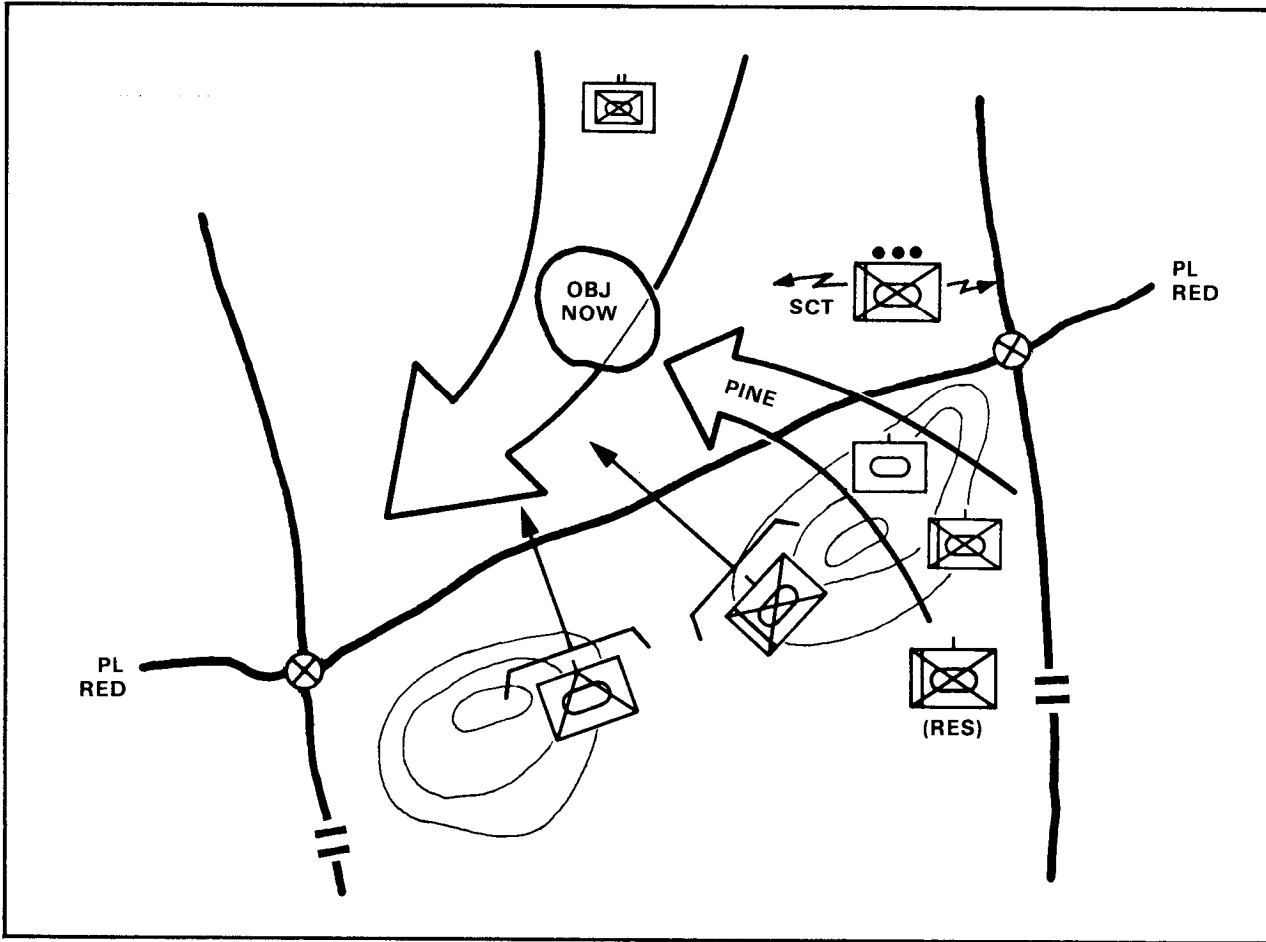

Figure 3-15. Hasty attack against a moving enemy force.

- (2) Tanks normally lead the attack; BFVs and TOWs overwatch and support the maneuvering tanks by fire.
- (3) FASCAM, smoke, and other supporting fires may be used to disrupt enemy maneuver and cover that of the task force.
- (4) The scouts and advance guard provide initial information on the enemy force and develop the situation.

- (5) The lead company team defends from hasty positions to fix the enemy element.
- (6) A company team seizes high ground to provide overwatch and flank security.
- (7) The trail team(s) counterattacks the enemy flanks supported by field artillery, antiarmor company, and CAS.
- (8) Task organization is not changed.

b. Attack Against a Stationary Force.

- (1) A hasty attack against a stationary force (composed mainly of individual fighting positions and hasty protective obstacles) is initiated after scouts or lead company teams reconnoiter the enemy's positions to find flanks or gaps that can be exploited. This must be done quickly to gain the initiative. The task force coordinates maneuver elements and supporting fires to avoid a piecemeal commitment of combat power.
- (2) The task force commander coordinates the actions of his subordinates through FRAGOs and previously issued contingency plans and control measures. He clearly states the time, direction, and objectives of the attack. He develops the situation to find and secure or clear approaches to the enemy's flank or rear.
- (3) Dismounted infantry assaults supported by direct and indirect fires may be necessary to defeat the enemy. Tanks support by fire and begin their assault timed to arrive on the enemy position at the same time as the dismounted infantry. Dismounted infantry clears the position before resumption of mounted movement.

c. Integration of Combat, Combat Support, and Combat Service Support Elements.

(1) Maneuver.

- (a) **Scout platoon.** During the hasty attack, the scout platoon quickly determines enemy locations and dispositions. It is then deployed to the battalion's most critical flank in a screen role, or beyond the objective to provide early warning of enemy reinforcement.
- (b) **Antiarmor company.** Antiarmor platoons are deployed quickly to positions that provide overwatch to the main attack.

(2) Fire support.

- (a) **Field artillery.** Priority of support is to maneuvering elements.
- * (b) **Mortars.** Mortars provide general support to the battalion. Priority of support is to smoke operations to facilitate maneuver.
- (c) **Air Force.** Immediate CAS is requested to support the battalion's main attack.
- (3) **Intelligence.** GSRs are deployed to cover possible avenues of approach into the flank(s) of the attacking battalion.

- (4) **Air defense artillery.** ADA assets move as closely as possible to the attacking company team to provide protection from enemy air.
- (5) **Mobility, countermobility, survivability.**
 - (a) **Engineers.** During the hasty attack, engineers move with the lead company team to assist in breaching obstacles and provide mobility support to follow-on company teams.
 - (b) **NBC.** Chemical (nonpersistent) agents are planned to interdict threat counterattacking forces.
- (6) **Combat service support.**
 - (a) **Combat trains.** At the initiation of the hasty attack, the combat trains deploy to a location that will not interfere with the maneuver of battalion task force company teams, or the elements of follow-on units. The combat trains CP eavesdrops on the operation, anticipates logistical requirements, and prepares to “push” them forward.
 - (b) **Medical platoon.** The aid station establishes operations near an MSR or easily identifiable spot and prepares to triage and evacuate wounded.

3-24. DELIBERATE ATTACK

- a. Task force deliberate attacks differ from the hasty attack in that they are characterized by precise planning based on detailed information, thorough preparation, and rehearsals. Deliberate attacks normally include large volumes of supporting fires, main and supporting attacks, and deception measures.

- b. The tank or mechanized infantry battalion will normally conduct a deliberate attack as the main or supporting effort of a brigade attack, or as the brigade reserve.
- c. A deliberate attack requires time for collecting and evaluating enemy information, reconnoitering, planning, and coordinating. The attack may be made from positions in contact or through a forward unit following a passage of lines. Attachments and task organization may be changed to fit the concept of operation. The commander must provide the necessary combat support for each company team and establish proper command and control relationships between units. The commander should designate support, breaching, and assault forces and position them in the attack formation for anticipated breaching operations.
- d. Detailed plans for fire and maneuver are completed for an area that has been reconnoitered. Planning for actions beyond the limit of reconnaissance is less restrictive, with maneuver of forces and firepower planned in broader terms to provide flexibility and allow initiative.
- e. In planning a deliberate attack, the principles of command and control discussed in Chapter 2 are applied. The commander and staff —
 - Adhere, as a minimum, to the 1/3 - 2/3 rule.
 - Follow troop-leading procedures to use available time efficiently.
 - Issue warning orders to initiate leader reconnaissance, movement, and subordinate unit planning and preparation.
 - Conduct detailed reconnaissance and IPB to determine precise locations, orientations, dispositions, and intent of the enemy.
 - Use a reverse planning process to develop detailed plans from the objective area back to the LD or assembly area.
 - Designate a main attack.
 - Task-organize maneuver units to support the main effort for each phase of the operation.
 - Ensure that coordination and synchronization of maneuver, CS, and CSS assets is built into the plan and supports the main attack.
 - Deliver the order from a vantage point that overlooks the terrain and ensure that the order contains a clear statement of mission and intent.

- Conduct rehearsals of the fire support plan and, to the extent possible, the movement plan.
- Conduct continuous reconnaissance and schedule a final intelligence update just before the attack.

3-25. TECHNIQUES FOR THE DELIBERATE ATTACK

- a. The commander employs those techniques that will avoid striking the enemy's main strength. He uses deception to deceive the enemy as to the point of the main attack; he uses surprise to take advantage of his initiative in determining the time and place of his attacks; and he uses the indirect approach to strike the enemy on the flanks and rear.
- b. Battalion task forces penetrate enemy company defenses to isolate and destroy elements of platoon size or smaller. The battalion task force completes the defeat of the enemy company in detail. Throughout the attack, the task force remains ready for enemy counterattacks and prepared to exploit success.
- c. The coordinated attack is usually conducted in four phases. The task force will —
 - Close on the objective.
 - Isolate the site for penetration.
 - Breach or penetrate to gain a foothold into the position.
 - Exploit the penetration.
 - (1) **Close on the objective.** The commander uses terrain or limited visibility or both to avoid enemy fires and to exploit weaknesses or gaps in the enemy defense. Envelopment is the preferred form of maneuver. When natural cover and concealment is unavailable, the commander uses smoke, suppression, and speed to minimize exposure to enemy weapons systems. Enemy "fire sacks" are avoided.
 - (2) **Isolate the site for penetration.** Regardless of the form of maneuver used to close on the objective, a penetration is usually required during the deliberate attack.
 - (a) The commander masses overwhelming combat power at the point of initial penetration.
 - (b) Artillery and mortar fires (including smoke) are used to suppress adjacent enemy positions and isolate the objective.

- (c) Overwatch is positioned where direct fire weapons can support the assault and prevent enemy reinforcement.
- (d) Envelopment is the preferred form of maneuver at every echelon. The enemy is attacked from a favorable direction based on his strength and orientation. Deliberate attacks are normally conducted against prepared defenses and require the infantry to dismount in the assault. The stronger the defenses, the more deliberate and methodical the attack and the greater the reliance on dismounted infantry.

(3) Breach or penetrate to gain a foothold.

- (a) Infantry dismounts outside the range of enemy direct fire weapons systems and moves forward by covered and concealed routes under the protective fires of tanks and BFVs positioned in overwatch.
- (b) The penetration of the enemy position is made on a narrow front. Bypass of obstacles is preferred to breach. The breach must lead to an exploitable weakness or gap in the enemy's defenses.
- (c) The infantry uses breaching and assault techniques similar to those used in the assault of a complex obstacle, and will reduce trench lines, bunkers, fortified positions, and the antitank weapons in them.

(4) Exploit the penetration.

- (a) Tanks will frequently follow the dismount elements and support from close overwatch. Tanks then move to exploit the initial breach as quickly as possible.
- (b) Bradleys use the long-range stabilized fire of the 25-mm gun and TOW to provide effective overwatch fires. Bradleys will leave overwatch when the antitank defenses are destroyed and assist in exploiting the breach and holding the shoulders of the penetration.
- (c) Reconnaissance elements use the penetration to reposition as required and obtain information on enemy positions in depth.
- (d) Reserves widen and deepen the penetration, and prepare to repulse counterattacks.
- (e) Once the objective is cleared, the mounted attack is continued to subsequent objectives or the task force begins consolidation and reorganization.

- d. The battalion task force must integrate and coordinate combat, combat support, and combat service support to capitalize on them as combat multipliers.
- (1) **Maneuver.** Normally, the task force scheme of maneuver for a deliberate attack employs three elements: main attack, supporting attack, and reserve.
 - (a) **Main attack.** The mission of the main attack is to penetrate the enemy's defenses and secure the terrain to be seized. The main attack emphasizes the indirect approach.
 - (b) **Supporting attack.** The mission of the supporting attack is to fix or suppress an enemy force not being directly assaulted by the main attack. The supporting attack accomplishes its mission by emphasizing fire rather than maneuver. The fires of the supporting attack must be combined with indirect fires to achieve the maximum effectiveness.
 - (c) **Reserve.** The task force normally retains a reserve to complete the destruction of the enemy's position or to exploit the success of the attack. The reserve may be used initially to overwatch the main attack.
 - (d) **Scout platoon.** During the preparation for the deliberate attack, the primary mission of the platoon is reconnaissance missions to gather intelligence on enemy defensive locations, orientation, and dispositions. Zone reconnaissance missions to facilitate the movement of the main, supporting, and reserve units are a secondary mission. During the attack, the scout platoon's mission is to report enemy repositioning and counterattack. It prepares to screen to the front of the battalion task force upon consolidation of the objective.
 - (e) **Antiarmor company.** Antitank elements are normally positioned to provide overwatch and support-by-fire onto the objective and potential enemy counterattack routes.
 - (2) **Fire Support.**
 - (a) **Field artillery.** The task force commander employs field artillery to aid his company teams in moving forward. In the deliberate attack, preparation fires and/or series of targets are often planned and delivered on the objective in accordance with a predetermined time schedule. The commander plans fires to suppress, isolate, and blind the enemy forces in and about the

axis of advance and objective area. These fires are both smoke and HE. In addition, short duration FASCAM is used to help isolate and impair the enemy's ability to counterattack.

- (b) **Mortars.** Mortars move well forward with the main effort. Although they can provide HE suppression, their primary mission is smoke placed in front of the objective and between the task force and the enemy to conceal friendly movement and isolate the enemy by obscuring enemy weapon systems. Once on the objective, the mortars position to provide general support to the battalion task force defense.
 - (c) **Air Force.** Close air support missions are planned and flown at the request of the battalion task force. The number of sorties received is dependent on the number allocated by brigade. The deliberate attack planning process requires detailed planning, integration, and coordination of CAS with the battalion task force scheme of maneuver. Tank and artillery positions are the priorities of CAS in the deliberate attack.
- (3) **Air defense artillery.** During the deliberate attack, ADA assets are positioned well forward to support the main effort. ADA coverage for the main effort is focused against likely air avenues of approach and concentrated at choke points and river crossing sites.
- (4) **Mobility, countermobility, survivability.**
- (a) **Mobility.** Normally, reconnaissance is done by troops who are to breach obstacles, accompanied by an engineer who will assist in the assessment of obstacles. Engineer elements are employed well forward with the main attack to enhance mobility. They accompany the breaching force and assist in reduction and crossing of obstacles encountered. In the deliberate attack, stealthy prebreach of obstacles by engineers or dismounted infantry is a preferred technique.
 - (b) **Countermobility.** Short duration FASCAM can be planned behind an enemy unit to seal withdrawal routes or counterattack routes.
- (5) **Combat service support.** The combat trains normally do not accompany the battalion task force during the deliberate attack. They remain in a location and readiness posture that allows them to move forward rapidly to planned locations from which to effect CSS upon consolidation on the objective.

3-26. ATTACK OF A STRONGPOINT

During offensive operations, enemy strongpoints may be encountered. The task force commander must assume that a stationary enemy has completed, or is in the process of completing, a strong defensive position. If the strongpoint cannot be bypassed, or neutralized, a deliberate attack may be necessary to destroy it. Attacking a strongpoint requires more artillery, smoke, and engineer support than a normal offensive operation. There are four steps in the process of destroying an enemy strongpoint:

- Reconnoiter and task-organize to take advantage of enemy weaknesses.
- Isolate the point of initial penetration with smoke and fires.
- Breach or find bypass routes around obstacles and gain a foothold into the position.
- Exploit this penetration to complete the destruction of the strongpoint.

a. Reconnoiter and task-organize.

- (1) Reconnaissance of the strongpoint is conducted in the same manner as reconnaissance for a deliberate attack.
- (2) The task force organizes into a breaching force, a support force, and an assault force. A company-sized reserve is retained or part of the support force is designated as reserve.
 - (a) The breach force is usually formed around a mechanized infantry company. Engineers, if available, are part of the breach force. Any mechanical breaching equipment is also attached to this force. The breach force makes the initial breach and passes the assault force through it.
 - (b) The support force is organized to provide supporting direct (and indirect) fires to the breach force initially, then to the assault force. The support force may consist of tank companies or tank-heavy company teams and the antiarmor company.
 - (c) The assault force is usually a mechanized-infantry-heavy company team. The assault force may be required to breach enemy close-in obstacles and should, therefore, include infantry and, if available in adequate mass, engineers. The assault force attacks through the breach and destroys the enemy position.

- b. **Isolate the Point of Penetration.** The decisive point is the site on which the initial breach of the enemy position will occur. This point will be the weakest platoon position in the strongpoint. This position must be isolated by intense direct and indirect fires and smoke to destroy enemy positions and to prevent lateral movement to reinforce this platoon. Units attack by fire against assigned objectives or at the direction of a single individual such as the task force S3. The task force commander is normally with the assaulting or breaching elements. Indirect fires and smoke are planned in groups and series to ensure continuous fires isolate the enemy.
- c. **Breach and Penetrate.** The breach of the enemy strongpoint is the task force initial main effort (see Figure 3-16). The breach force breaches the enemy's protective obstacles, gains a foothold in the trench line, and creates a gap in the strongpoint large enough to pass through the assault force. In planning the breach operation, the following are considered:

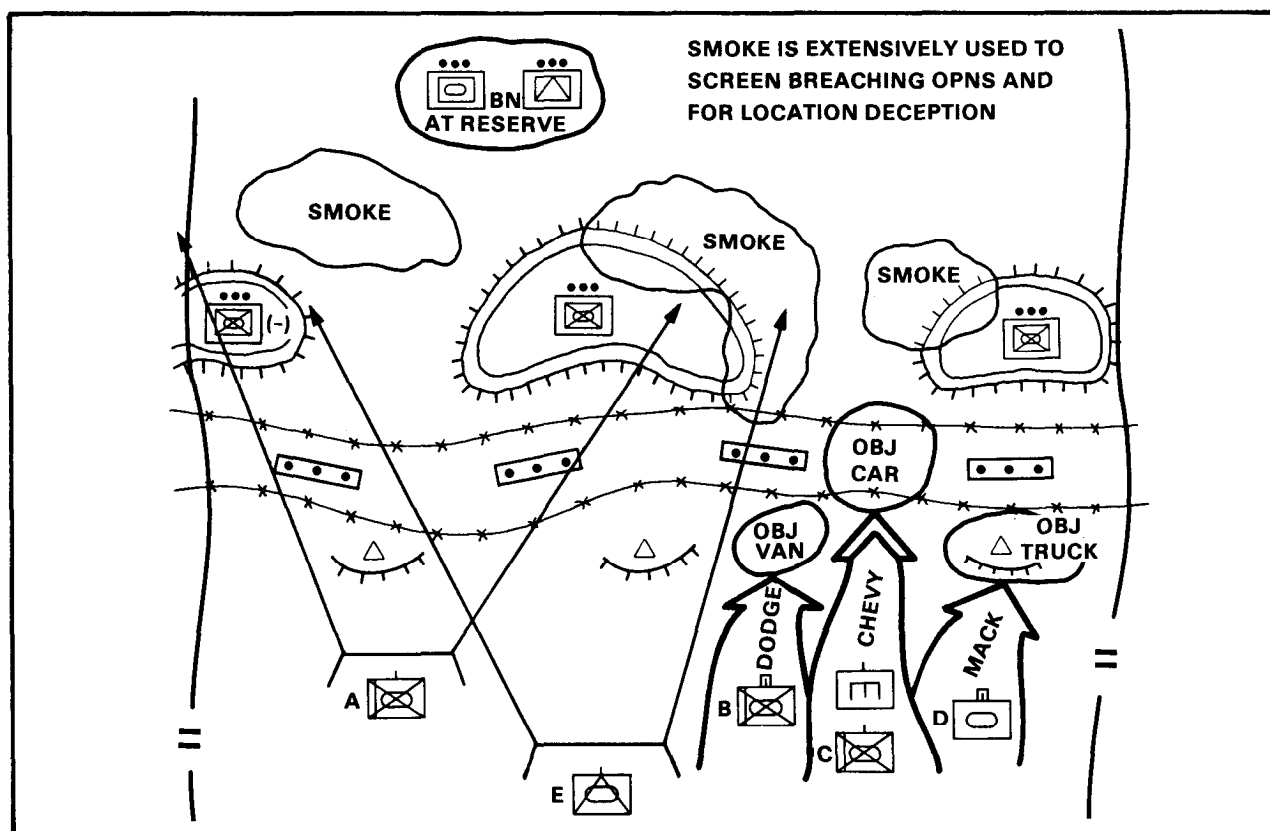

Figure 3-16. Attack of a strongpoint — the breach.

- (1) Tanks and BFVs support by fire, while dismounted infantry and engineers move along covered and concealed routes to the penetration point. The primary mission of engineers is the breaching of the outer and larger obstacles that protect the main position. The dismounted infantry breaches minor obstacles and assaults to clear or destroy trench lines, bunkers, fortified positions, and the antiarmor weapons in them. If available, mechanical breaching devices are used.
 - (2) If sufficient obstacle lanes have been cleared, tanks follow and support the dismount elements by fire. Tanks move quickly to exploit the initial breach.
 - (3) BFVs initially support by fire and are called forward when the antiarmor defenses are destroyed. They then assist in holding the shoulders of the penetration.
 - (4) The initial penetration is made on a narrow front by the assault force. The concept is to make a narrow penetration into the enemy's defenses and then widen, deepen, and exploit it.
 - (5) Gaps between units should not be allowed to develop. Mutual support between attacking elements is maintained so that they are not isolated and defeated. As the task force penetrates the enemy position, it can expect the enemy to counterattack to cut off the penetration. The enemy emphasizes an extensive system of communication trenches to permit counterattacks by their dismounted infantry. Therefore, it is important to quickly secure decisive points within the enemy's position, widen the initial penetration, and push forces deeper into the stronghold.
 - (6) Overwhelming suppressive fire and smoke is planned to hide and protect assault breaching efforts. Counterbattery fires may also be coordinated.
 - (7) Breaching may also be accomplished by stealth as a preparatory action by engineers or dismounted infantry.
- d. **Exploit the Penetration.** After the successful breach, the assault force becomes the task force main effort (see Figure 3-17). The assault force passes rapidly through the breach, supported by the fires of the support force and the breach force. The assault objective is an isolated enemy platoon position. In planning the assault, consider the following points:
- (1) The assault force must get to and destroy the enemy platoon position. If the assault force can get to the rear of the

strongpoint, the remainder of the task force can neutralize the remaining platoon strongpoints by attacking from positions on the flank or rear.

- (2) The assault force must also organize into support, breach, and assault elements. As subsequent platoon positions are encountered, the breaching process may have to be repeated. As in the initial breach, BFVs support by fire while the tanks and dismounted infantry complete the reduction of the strongpoint and associated trench lines.
- (3) The task force commander should be prepared to commit the reserve to complete the destruction of the strongpoint and prepare for a counterattack or continue to attack.

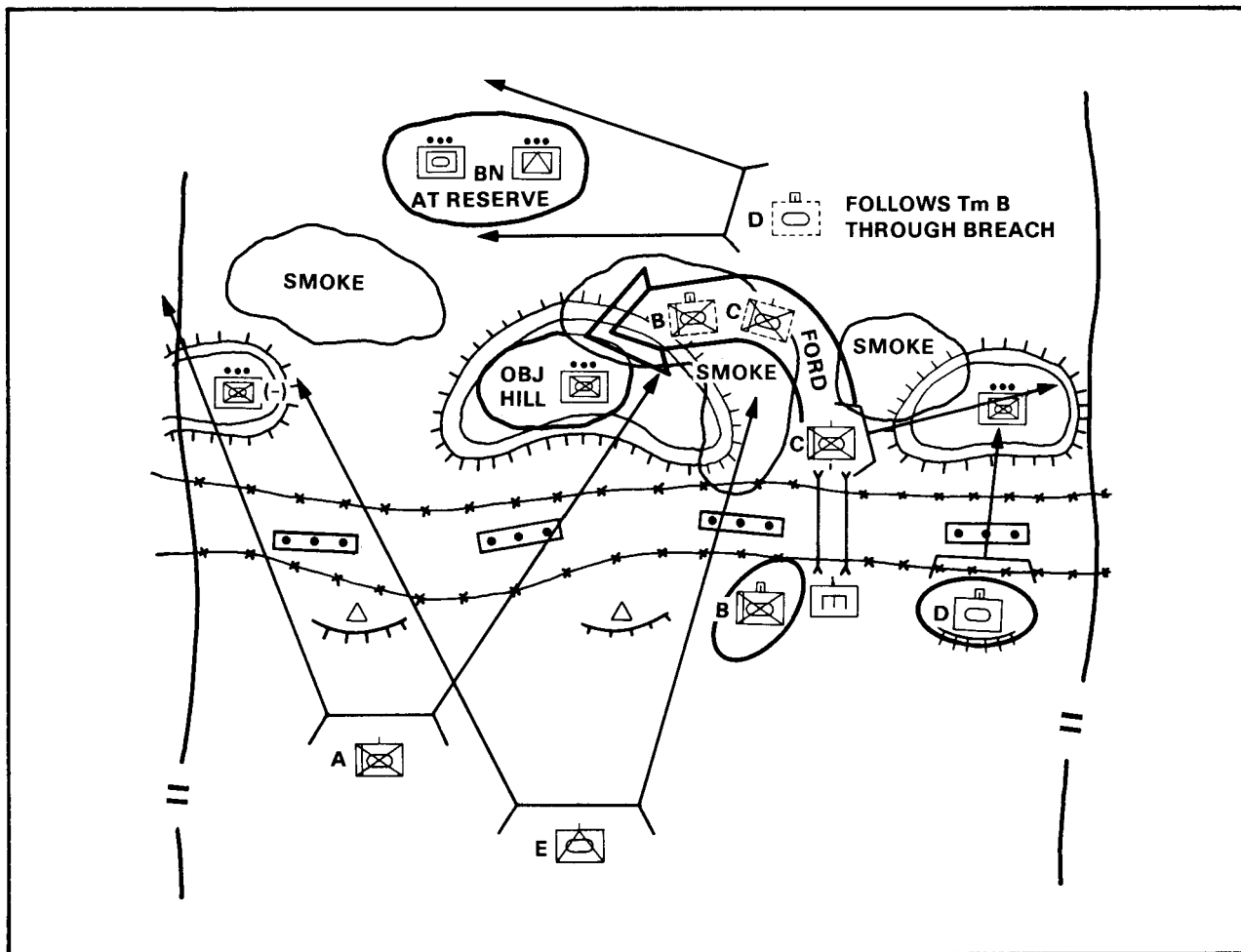

Figure 3-17. Attack of a strongpoint — the assault.

Section V. OTHER OFFENSIVE OPERATIONS

3-27. EXPLOITATION

- a. The exploitation is conducted to take advantage of success in battle. Exploitation prevents the enemy from reconstituting an organized defense or conducting an orderly withdrawal. It may follow any successful attack. The task force normally participates in the exploitation as part of a larger force. The keys to successful exploitation are **speed** in execution and maintaining direct **pressure** on the enemy.
- b. Opportunities for exploitation are indicated by —
 - An increase in the number of enemy prisoners.
 - An increase in abandoned materiel.
 - The overrunning of artillery, command facilities, signal installations, and supply dumps.
 - A decrease in enemy resistance.
 - A breakdown in enemy command and control as evidenced by confusion and a loss of cohesion.
- c. Exploiting force missions include —
 - Securing objectives deep in the enemy rear.
 - Cutting lines of communication.
 - Surrounding and destroying enemy units.
 - Denying escape routes to an encircled force.
 - Destroying enemy reserves, CS, and CSS units and assets.
- d. The task force conducting an exploitation moves rapidly to the enemy's rear area using movement to contact techniques, avoiding or bypassing enemy combat units, and destroying lightly defended and undefended enemy installations and activities. Bypassed enemy forces are reported to brigade headquarters for destruction by follow-and-support forces. The task force is usually assigned an objective deep in the enemy rear based on the higher commander's intent. This objective may be one that will contribute significantly to the destruction of organized resistance or one for orientation and control.
 - (1) If the mission is to seize or secure a deep objective, the task force avoids engagements and moves to the objective as quickly as possible.

- (2) If the objective is assigned for orientation and control, the task force seeks targets anywhere in its zone of action or along its axis of advance. In this case, the exploitation is executed as a tank sweep.
- e. The exploitation continues day and night for as long as the opportunity permits. The initial plan must ensure that adequate stocks of fuel, spare parts, ammunition, protective clothing, decontaminants, medical supplies, and food are available to the task force. The momentum of the exploitation must not be slowed because of lack of support. Aerial resupply may be requested during the exploitation.

3-28. PURSUIT

- a. The pursuit normally follows a successful exploitation. It differs from an exploitation in that a pursuit is oriented primarily on the enemy force rather than on terrain objectives. While a terrain objective may be designated, the enemy force is the primary objective. The purpose of the pursuit is to run the enemy down and destroy him.
- b. The task force participates in the pursuit as part of a larger force. The pursuit is conducted using a direct-pressure force, an encircling force, and a follow-and-support force. The task force may comprise or be part of any of these forces.
 - (1) The direct-pressure force denies the enemy units the opportunity to rest, regroup, or resupply by repeated hasty attacks to force them to defend without support or to stay on the move. The direct-pressure force envelops, cuts off, destroys, and harasses enemy elements.
 - (2) The encircling force moves with all possible speed to get in the enemy rear, block his escape, and, with the direct-pressure force, destroy him. The enveloping force advances along routes parallel to the enemy's line of retreat to establish positions ahead of the enemy main force.
 - (3) The follow-and-support force is organized to destroy bypassed enemy units, relieve direct-pressure force elements, secure lines of communication, secure key terrain, or guard prisoners or key installations.
- c. Engineers in exploitation and pursuit operations should be well forward in the columns to aid the movement of the force. Breaching equipment must be well forward in anticipation of encountering and breaching destroyed bridges, road craters, abatis, and interdiction mining.

- d. CSS is critical to the success of the pursuit. Techniques of sustainment operations are the same as for exploitation.

3-29. RECONNAISSANCE IN FORCE

- a. A reconnaissance in force (see Figure 3-18) is a deliberate attack to discover and test enemy disposition, composition, and strength. Reconnaissance in force is ordered by a division or higher commander.
- b. The battalion task force is the smallest force used to conduct a reconnaissance in force. The TF normally moves on a broad front. A reserve is maintained to exploit enemy weakness. Its aim is to determine enemy dispositions and strength. However, the reconnaissance in force may uncover weaknesses that, if promptly attacked, would permit an immediate tactical success. Objectives are designated on terrain that will force the enemy to react. A reconnaissance in force is planned and conducted using the following considerations.
 - (1) When some knowledge of the enemy is available and the enemy is defending or temporarily halted, the reconnaissance in force may be conducted to obtain specific and detailed information on his location and disposition.
 - (2) Necessary information cannot be gathered by other systems.
 - (3) The possibility that future plans may be revealed to the enemy by the reconnaissance in force must be weighed.
 - (4) There is the possibility that the reconnaissance in force may lead to a general engagement under unfavorable conditions that may require extrication.
- c. If the reconnaissance in force finds a gap or weak point in the enemy's defense, the higher headquarters must be prepared to immediately exploit. The higher commander does this by directing the task force conducting the reconnaissance in force to continue the attack, or he may commit additional forces to pass through and continue the attack.

3-30. ATTACKS FROM A DEFENSIVE POSTURE

Attacks from a defensive posture include counterattack and spoiling attacks as either hasty or deliberate operations. The task force can conduct counterattacks and spoiling attacks as part of a brigade or higher defense, or it may order a subordinate unit to conduct a counterattack as part of the task force defensive plan.

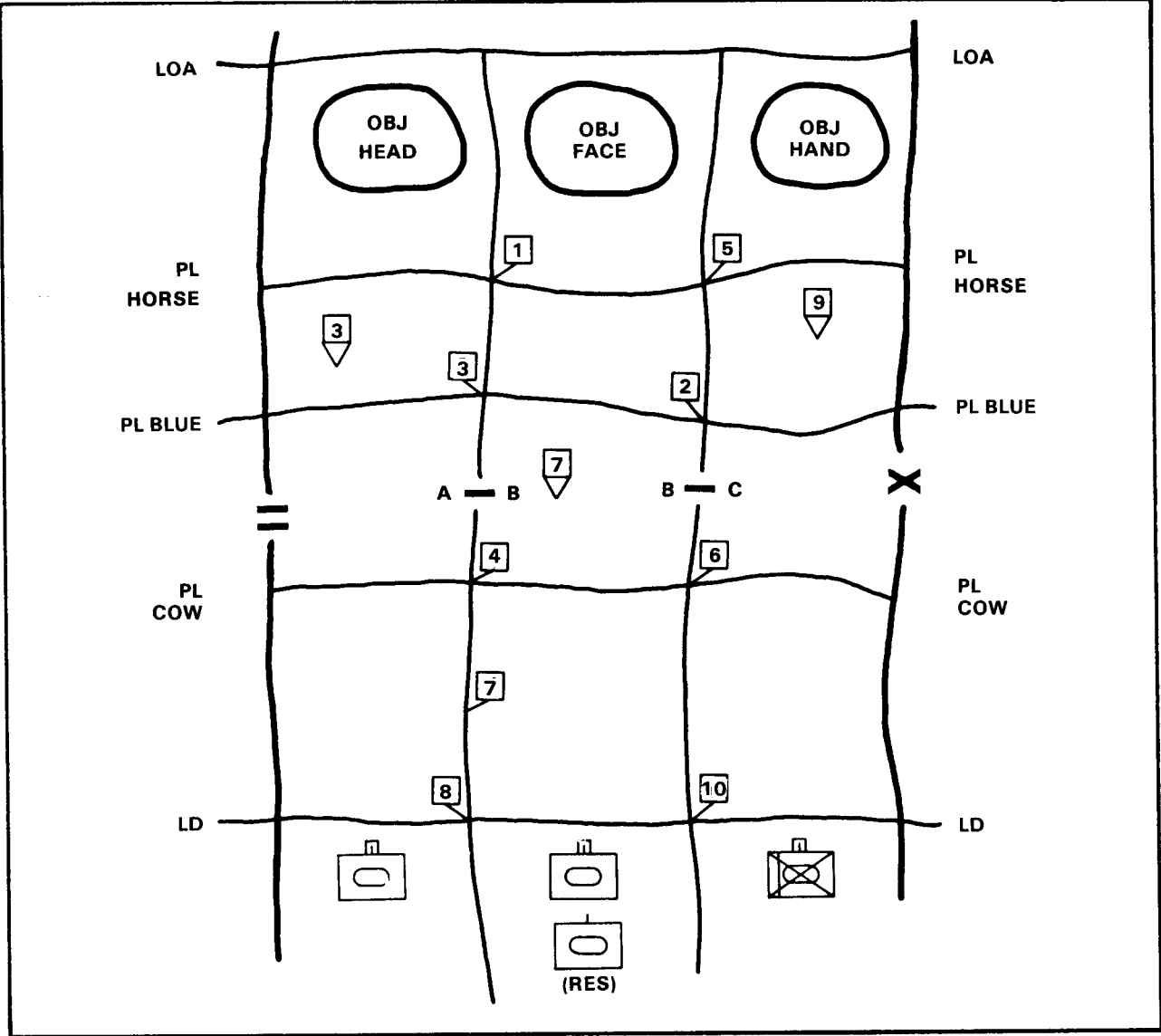

Figure 3-18. Reconnaissance in force.

a. **Counterattack.** The counterattack attempts to defeat an attacking enemy or regain key terrain. Counterattacks may be conducted by a reserve or lightly committed forward element. Timing is critical, and any delay or preparatory movement allows the enemy time to react. Therefore, thorough counterattack planning and rehearsals should be done in advance. Normally, the commander prioritizes counterattack missions for planning

by the reserve and establishes appropriate control measures (including routes, LD/LCs, attack-by-fire positions or objective areas, and other fire control measures) for each. The counterattack is launched when the commander senses that the balance of power on the battlefield has changed and he can exploit the situation by counterattacking to seize the initiative. Once the reserve is committed, another should be reconstituted.

- b. **Spoiling Attack.** The spoiling attack attempts to strike the enemy when he is most vulnerable, during preparations for attack in assembly areas, attack positions, or on the move before crossing his line of departure. Usually, circumstances preclude full exploitation, and the attacking force halts on its objective or withdraws to its original position. Because of the distances and force ratios involved, companies do not conduct spoiling attacks, except as a raid.

Planning considerations for attacks from a defensive posture are discussed in Chapter 4.

3-31. FOLLOW-AND-SUPPORT

- a. Follow-and-support forces are normally battalion task forces or higher formations employed primarily in exploitation and pursuit operations to facilitate maintaining the momentum of the attack. They may also be used in the conduct of a penetration. A force with a follow-and-support mission is a committed unit.
- b. Follow-and-support forces assist attacking units by relieving them of tasks that would otherwise slow their advance. These tasks include —
 - Destroy bypassed pockets of resistance.
 - Relieve elements of the attacking force that have been left to block or contain enemy forces.
 - Secure the flanks of a penetration to prevent the enemy from closing it.
 - Expand the area of the penetration by breaking through other enemy defenses.
 - Secure lines of communications.
 - Secure key terrain overrun or bypassed by the attacking unit.
 - Protect key installations.
 - Guard prisoners of war.

- c. When augmented with additional CSS assets, follow-and-support forces may also be assigned missions such as control of refugees and casualty collection and management.
- d. When operating as a follow-and-support force, task force movement techniques are similar to those used in the movement to contact. Plans are coordinated with the unit that the task force follows, and the tactical CP moves initially with that unit's tactical CP. The task force main CP monitors the command net of the unit it is following.

3-32. RAID

- a. A raid (see Figure 3-19, page 3-68) is an attack into enemy territory to accomplish a specific purpose and with no intention of gaining or holding terrain. Raids may be conducted to —
 - Capture prisoners.
 - Capture or destroy specific enemy materiel.
 - Destroy logistical installations.
 - Obtain information concerning enemy locations, dispositions, strength, intentions, or methods of operation.
 - Disrupt enemy plans.
- b. Battalion task forces may conduct, or may direct subordinate elements to conduct, a raid.
- c. Raids may be conducted mounted or dismounted, and may be accomplished through infiltration or air assault. Mounted raids normally are conducted as an exploitation with a limit of advance, or as an attack with a limited-depth objective. Dismounted raids are conducted as a combat patrol.
- d. Raids may be conducted in daylight or darkness, within or beyond supporting distance of the parent unit. Air assault raids have a greater chance of success during hours of darkness and low illumination. When the area to be raided is beyond supporting distance of friendly lines, the raiding party operates as a separate force.
- e. Raiding force security is vital, because the raiding party is vulnerable to attack from all directions.
- f. Raids are timed so that the raiding force arrives at the objective area at dawn, twilight, or other times of low visibility. Fire support, if in range, is well planned.

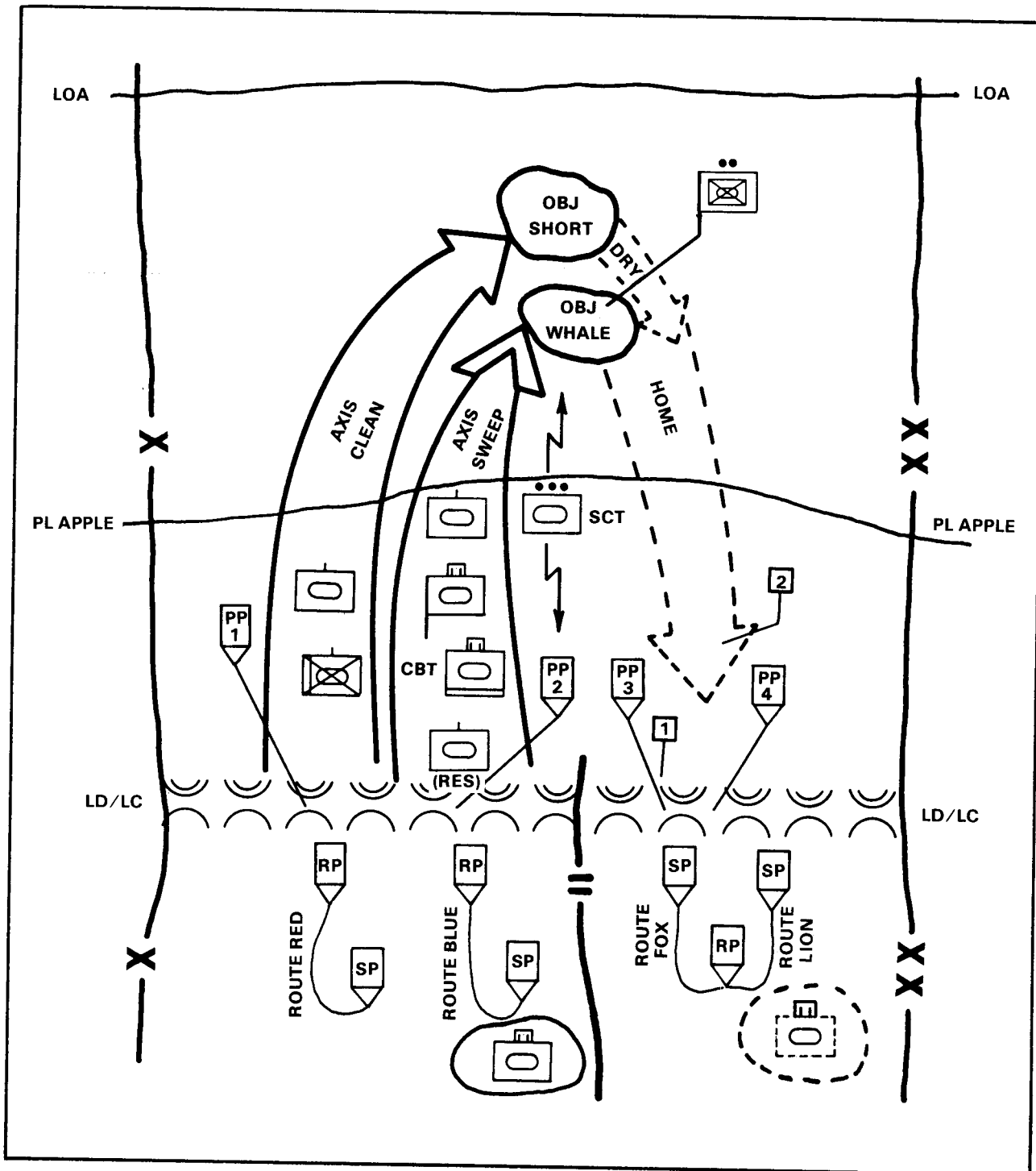

Figure 3-19. Raid.

- g. During movement in daylight, the raid force uses covered routes of approach. During reduced visibility, when surprise through stealth is possible, advance and flank security detachments precede the raiding force. They prevent premature discovery of the raid by locating enemy security detachments and directing the raiding party around them.
- h. The withdrawal is usually made over a different route from the one used to approach the objective. Security detachments are employed to ensure that the routes of withdrawal are open. Protective fires are planned along the axes of advance and withdrawal.
- i. Rally points are planned for units to assemble to prepare for the attack on the objective, or to assemble after they have completed the mission and are ready to withdraw.
- j. Logistical considerations in raids include the type and number of vehicles and weapons that the raiding force will have, movement distance, length of time the raiding party will operate in enemy territory, and expected enemy resistance. Usually, the raiding force carries everything required to sustain itself during the operation. Resupply of the raiding force, if required, is by aircraft.

3-33. FEINT

A feint is a supporting offensive operation to draw the enemy's attention away from the area of the main attack and induce him to move his reserves or shift his fire support. Feints must appear real. **Contact with the enemy is required.** Planning considerations are:

- a. The higher commander's intent must be defined and understood to avoid the loss of the force conducting the feint.
- b. Sufficient assets must be provided to the force conducting the feint to ensure mission accomplishment and unit survival.
- c. Clear follow-on orders must be issued to ensure that the feinting force is prepared to exploit the success of the main attack if required.
- d. Limited depth objectives are assigned.

3-34. DEMONSTRATION

The demonstration is an operation to deceive the enemy about the main attack. Its purpose is similar to a feint; however, **no contact**

with the enemy is made. Demonstrations support a division or corps operations plan. Planning considerations are:

- a. The limit of advance must be carefully selected to allow the enemy to “see” the force but not to effectively engage it with direct fire.
- b. The force must be protected from surprise attack or enemy spoiling attacks.
- c. Follow-on missions must be planned so that the task force can leave the demonstration area and not be destroyed by indirect fire.

CHAPTER 4

DEFENSIVE OPERATIONS

This chapter describes the planning, preparation, and execution of defensive operations. It emphasizes the requirement for initiative and the need to accept risk in one part of the battlefield in order to mass combat power in another. The defense employs offensive, defensive, and delaying actions to destroy the enemy. To be successful, the task force commander must attack the enemy with concentrated fires and maneuver throughout the battlefield.

CONTENTS	
PARAGRAPH	PAGE
Section I. FUNDAMENTALS OF THE DEFENSE	4-2
4-1 Purpose of Defense	4-2
4-2 Characteristics of Defensive Operations.	4-3
4-3 Framework of the Defense	4-5
Section II. THREAT OFFENSIVE DOCTRINE	4-7
4-4 Threat Attack Planning	4-7
4-5 How the Threat Attacks	4-8
Section III. PLANNING FOR DEFENSIVE OPERATIONS	4-8
4-6 Planning	4-8
4-7 Defensive IPB	4-11
4-8 Unit Positioning	4-12
4-9 Combat Support	4-16
4-10 Additional Considerations	4-19
4-11 Synchronization of Defensive Operations.	4-24
4-12 Sequence of the Defense	4-26
4-13 Battle Handover	4-27
Section IV. TYPES OF DEFENSE	4-30
4-14 Defense of a Sector	4-30
4-15 Defense of a Battle Position	4-37
4-16 Defense of a Strongpoint	4-39
Section V. RESERVE OPERATIONS	4-42
4-17 Counterattack	4-42
4-18 Spoiling Attack	4-44
4-19 Block, Fix, or Contain	4-45
4-20 Reinforce	4-46
4-21 Rear Operations	4-46

PARAGRAPH	PAGE
Section VI. OTHER DEFENSIVE OPERATIONS AND TECHNIQUES	4-47
4-22 Counterreconnaissance Operations	4-47
4-23 Stay-Behind/Hide Forces.	4-50
4-24 Perimeter Defense	4-55
4-25 Reverse Slope Defense	4-57
4-26 Urban Area Operations	4-61

Section I. FUNDAMENTALS OF THE DEFENSE

AirLand Battle doctrine stresses gaining the initiative through offensive action. In defensive operations, this implies the ability to make a quick transition to the offense by maintaining a reserve force and shaping the battlefield to make counterattacks possible. The task force may defend in sector, from battle positions, and from strongpoints. Supporting fires and reinforcing obstacles are planned to assist in shaping the battlefield, to slow and confuse the enemy, and to destroy the continuity of enemy formations.

The defensive positions are usually nonlinear, and the battle is planned and fought in depth. The battle starts forward of the FEBA. Supporting indirect fires are planned and used as early as tactically feasible. The initiative must be taken from the attacking enemy, and he may be attacked before he closes on the MBA. A reserve should be available to counterattack at the critical point to destroy the enemy and halt his advance. The defense orients on defeating the enemy, not on maintaining the initial FEBA trace. Flexibility and concentration are the keys to the defense. Forward company teams not being attacked reposition or counterattack to contribute to the battle.

4-1. PURPOSE OF DEFENSE

The purpose of defense is to defeat the enemy’s attack and gain the initiative for offensive operations. Defense is a temporary measure conducted to identify or create enemy weaknesses that allow for the early opportunity to change over to the offense. Defensive operations achieve one or more of the following:

- Destroy the enemy.
- Weaken enemy forces as a prelude to the offense.
- Cause an enemy attack to fail.
- Gain time.
- Concentrate forces elsewhere.
- Control key or decisive terrain.
- Retain terrain.

4-2. CHARACTERISTICS OF DEFENSIVE OPERATIONS

a. Preparation.

- (1) The defender has significant advantages over the attacker. In most cases, he not only knows the ground better, but, having occupied it first, he has strengthened his positions. He is stationary and under cover in carefully selected positions, with prepared fires and obstacles.
- (2) The attacker, however, has the initiative to choose the time and place of battle. The attacker tries to shatter the defense quickly and prevent its reconstitution by continuing the attack at a fast pace. The defender must slow the attacker's tempo, thereby providing time to isolate, fight, and destroy the attacker.
- (3) Operational security is the defender's first requirement to defeat an attack. Units must maintain operational security, avoid patterns, and practice deception to hide the defender's disposition. Enemy reconnaissance efforts and probing attacks must be defeated without disclosing the scheme of defense. The reconnaissance battle is normally a prelude to the larger battle. The winner of the reconnaissance battle is usually the winner of the final battle.
- (4) An enemy attack is preceded and accompanied by massed supporting fires. To survive, units must use defilade, reverse slope, and hide positions; use supporting and suppressive fires; and avoid easily targeted locations. The defender must use all available time to prepare fighting positions and obstacles, to rehearse counterattacks, and to plan supporting fires and combat service support in detail.

- b. **Disruption.** An attacker's strength comes from momentum, mass, and mutual support of maneuver and combat support elements. The defender must slow or fix the attack, disrupt the attacker's mass, and break up the mutual support between the attacker's combat and combat support elements. This results in a piecemeal attack that can be defeated in detail. A general aim is to force the attacker to fight a nonlinear battle to make the attacker fight in more than one direction. This makes it more difficult for him to coordinate and concentrate forces and fires, and to isolate and overwhelm the defender. It also makes the securing of his flanks, combat support, combat service support, and command and control elements more difficult.
- c. **Concentration.** To gain local superiority in one area, the defender is often forced to economize and accept risks elsewhere. Reconnaissance and security forces enable him to "see" the battlefield, and thereby reduce risk. The defender should be able to rapidly concentrate forces, thereby massing combat power to defeat an attacking force, then disperse and be prepared to concentrate again. The main effort is assigned to one subordinate unit. All other elements and assets support and sustain this effort. The commander may shift his focus by designating a new unit to be the main effort if other units encounter unexpected difficulties or achieve success.
- d. **Flexibility.** Commanders designate reserves and deploy forces and logistic resources in depth to ensure continuous operations and to provide options for the defender if forward positions are penetrated.
 - (1) Contingency planning permits rapid action. Understanding the commander's intent and contingency plans allows subordinate commanders to rapidly exploit enemy weaknesses.
 - (2) Flexibility also requires that the commander "see the battlefield" to detect the enemy's scheme of maneuver in time to direct fires and maneuver against it. IPB determines likely enemy actions, while security elements verify which actions are actually taking place. The commander does not limit his intelligence gathering efforts only to the forces in contact, but also concentrates on formations arrayed in depth. The enemy may attempt to bypass areas where the defense is strong. Hence, the defending commander ensures that he is able to detect and react to enemy movement along all possible avenues of approach throughout the course of the battle. The defender must never allow the attacker to gain tactical surprise.

4-3. FRAMEWORK OF THE DEFENSE

The task force normally defends as part of a larger force. The defensive framework within which corps and divisions organize and fight is organized into five elements (see Figure 4-1):

- Deep operations forward of the forward line of own troops (FLOT).
- Security force operations forward of and to the flanks of the defending force.
- Main battle area (MBA) operations.
- Reserve operations in support of the main defensive effort.
- Rear operations to retain freedom of action in the rear area.

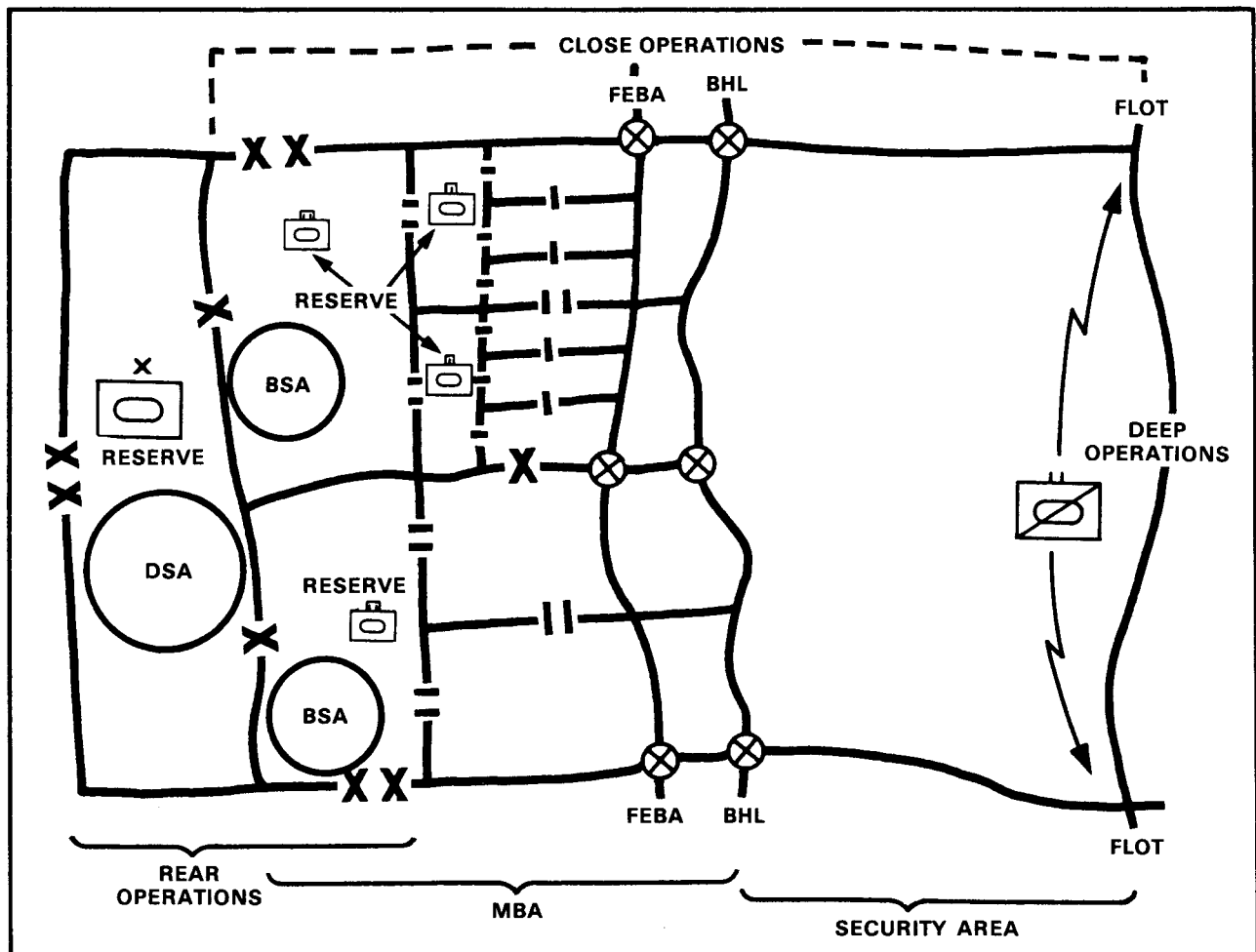

Figure 4-1. Organization for defensive operations.

a. Deep Operations.

- (1) Deep operations are actions against those enemy forces not yet in direct contact with the FLOT. Deep operations create opportunities for offensive action by reducing the enemy's closure rates; separating attacking echelons; disrupting his command and control, combat support, and combat service support; and slowing the arrival times of succeeding echelons. Deep operations are conducted using indirect fires, EW, Air Force and Army aviation, deception, and maneuver forces.
- (2) Task forces have no deep operations capabilities, although they may be part of a deep maneuver operation.

b. Close Operations.

(1) Security area operations.

- (a) The forward security force normally established by corps is called a covering force. It begins the fight against the attacker's leading echelons in the covering force area (CFA). Covering force actions weaken the enemy; permit the corps commander to reposition forces; and deceive the enemy as to the size, location, and strength of the defense.
- (b) A battalion task force may fight as a part of a covering force operation. When it disengages from the enemy, it becomes part of the MBA forces or reserve. MBA units assume control of the covering force battle at the battle handover line and assist covering force units to break contact and withdraw through the MBA.

(2) Main battle area operations.

- (a) Based on their estimate of the situation and intent, brigade commanders assign sectors or battle positions to task forces. Normally, assigned sectors coincide with a major avenue of approach, while battle positions and attack helicopter firing positions are on the flanks of main approaches. The brigade commander designates and sustains the main effort by giving priority of artillery, engineer, air defense, and close air support assets to the force responsible for the most dangerous avenue of approach into the MBA. The commander can strengthen the effort on the most dangerous avenue by narrowing the sector of the unit astride it.
- (b) Task force commanders structure their defenses by deploying units in depth within the MBA. A mounted reserve of one-quarter to one-half of the task force

strength provides additional depth and gives the commander a maneuver capability against the enemy. A commander can create a reserve by taking risk on less likely enemy avenues of approach in the MBA.

- (c) Penetration by enemy forces must be anticipated and provided for in the plan. Separation of adjacent units is likely, especially if the enemy is conducting nuclear and chemical operations. MBA forces continue to strike at the enemy's flank, and counterattack across penetrations.

(3) Reserve operations.

- (a) The commitment of reserve forces at the decisive point and time is key to the success of a defense. When the task force has been designated as a reserve force, it can expect to receive one or more of the following missions: counterattack; spoiling attack; block, fix, or contain; reinforce; or rear operations (see Section V).
 - (b) When the task force designates a reserve, its most common use is in the counterattack role. The composition, location, and mission of a reserve is based on the task force commander's estimate of the situation and intent.
- c. **Rear Operations.** The battalion task force does not have a rear operations fight within its assigned sector. However, a maneuver battalion assigned a rear mission by a higher headquarters may conduct offensive operations against enemy conventional or unconventional forces in the rear area.

Section II. THREAT OFFENSIVE DOCTRINE

When planning, preparing, and executing the defensive operation, the battalion commander and his staff must know how the threat will attack. This knowledge leads to an identification of probable courses of action, weaknesses, and vulnerabilities of the threat attack.

4-4. THREAT ATTACK PLANNING

- a. The Threat regiment will attempt to attack along brigade and battalion boundaries — where we are weakest. His objective will be a location or facility in the rear area. He will always mass and position his strength against known weaknesses, terrain

being considered equal. He identifies weaknesses through an aggressive reconnaissance effort before the attack. He will generally accept the problems inherent in marginal and adverse terrain rather than go against friendly strength. He studies terrain as only a limiting factor after he forms his initial attack concept. His use of deception to mask his timing, location, and or scope of the attack will be the norm rather than the exception.

- b. To carry out his attack, the threat commander expects to have an 80 percent complete intelligence picture of the battalions' initial and subsequent defensive positions. He will mass his forces to achieve at least a 3:1 superiority for his main attack.
- c. His attack will be preceded by strong concentrations of artillery within the main attack. Threat doctrine calls for 60 to 100 tubes of artillery per kilometer of main attack frontage.

4-5. HOW THE THREAT ATTACKS

The Threat strives to sustain continuous operations with overwhelming numbers through momentum, mass, and echelonment. The Threat uses combined arms formations of massed tanks, motorized (mechanized) infantry, and other armored vehicles supported by massed fires. See Figure 4-2 for an example Threat motorized rifle regiment attack.

Section III. PLANNING FOR DEFENSIVE OPERATIONS

This section implements QSTAG 567.

The defense is planned in detail, but the commander must remain flexible and willing to deviate from the plan when circumstances dictate or opportunities present themselves.

4-6. PLANNING

- a. The brigade order must be analyzed not only for specified and implied tasks but also for intent and the maneuver required to accomplish that intent. The following questions may assist the planner in this analysis.
 - (1) Is decisive engagement to be accepted, or is freedom of maneuver to be retained?

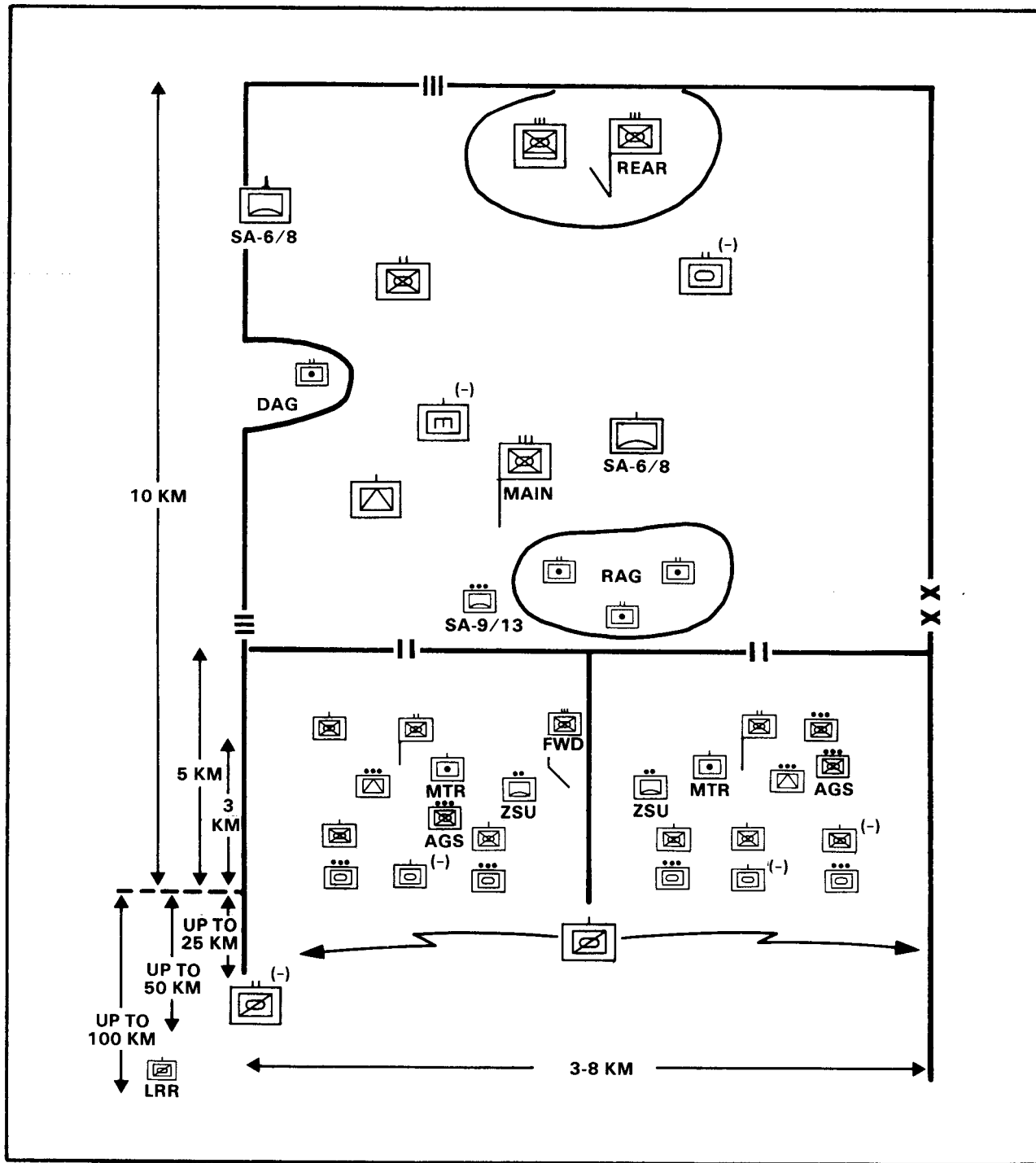

Figure 4-2. Threat regimental attack.

- (2) How are the brigade and division going to create weaknesses? How and with what forces are they going to attack weaknesses?
 - (3) How are counterattacks to be conducted, coordinated, and supported?
 - (4) How is the task force to tie in with adjacent units?
 - (5) Is there decisive terrain to be retained?
 - (6) What are subsequent missions? Contingency plans?
- b. General battalion task force defensive missions include defend, delay, and counterattack.
- (1) The mission to defend can apply to a sector, a battle position, or a strongpoint.
 - (a) Defense in sector requires the task force to defeat the attacker forward of the rear boundary. The task force may fight the battle using the entire depth of the sector consistent with the intent of the brigade commander and the requirement to tie in with adjacent units.
 - (b) Defense of a battle position requires the task force to occupy a general location from which it can block an avenue of approach, fire into an assigned area, retain key terrain, or perform other tasks.
 - (c) Defense of a strongpoint implies defense of an extensively fortified position that holds or controls decisive terrain or blocks an avenue of approach.
 - (2) Delay missions allow the forfeiture of terrain to gain time. Delays shape and deplete the enemy while giving other friendly units time to prepare.
 - (3) Counterattack can be by fire or maneuver (fire and movement).
 - (a) Counterattack by fire requires movement to a position to destroy the attacker by fire. The enemy force is the primary objective. Terrain seized is important only for as long as the enemy can be engaged from that location.
 - (b) Counterattack by maneuver implies the intent to close with and destroy the enemy or to capture key terrain.
- c. Besides the basic missions of defend, delay, and counterattack, numerous other tasks may be specified or implied in the brigade order. Examples are assisting the passage of covering or security forces, providing security, preparing obstacles, and providing surveillance or intelligence.

4-7. DEFENSIVE IPB

During IPB, the commander and his staff consider weather, enemy, and terrain to determine and analyze ground and air avenues of approach. Specific considerations for the analysis of avenues of approach include the following.

- a. Determining primary and secondary avenues of approach and mobility corridors.
- b. Determining key and decisive terrain. The staff identifies areas along the avenues of approach where speed and deployment of enemy formations is limited and where formations are broken up and exposed to counterattack. Key and decisive terrain will facilitate blocking the avenue of approach.
- c. Determining FROM THE ENEMY'S POINT OF VIEW—
 - (1) **Maneuver space.** Considering choke points and natural obstacles, how many armored vehicles and, hence, what size unit does each avenue of approach support?
 - (2) **Trafficability.** How do soil trafficability, ruggedness of terrain, weather, and limited visibility affect movement rates?
 - (3) **Cover and concealment.** What terrain allows movement as close to the defender as possible using column formations before deploying into assault formations?
 - (4) **Observation and fields of fire.** What terrain is suitable for supporting direct fire by tanks, ATGMs, attack helicopters, or self-propelled artillery?
 - (5) **Key/decisive terrain.** What terrain gives the enemy a decided advantage over the defender?
 - (6) **Limited visibility effects.** Smoke, dust, fog, and darkness all affect movement. During such periods, roads, ridgelines, and other features that facilitate navigation increase the value of an avenue of approach.
 - (7) **Enemy air avenues of approach.**
- d. Determining possible and probable enemy courses of action.
- e. Developing named areas of interest and target areas of interest to determine the attacker's intent and lessen friendly reaction time.

4-8. UNIT POSITIONING

The commander decides where to defeat the enemy based on IPB determination of avenues of approach, key terrain, and enemy vulnerabilities. He and his staff then develop courses of action and determine tentative unit positions.

- a. The task force commander arrays company-size forces against battalion-size avenues of approach. In doing this, he considers the positioning of platoons. The positions must provide for an integrated defense so that all available weapons systems can cover the approaches. Positioning should allow the shifting of fires and forces to meet enemy actions during the battle. Once this is completed, consideration is given to the formation of company teams.
- b. The task force organizes and assigns missions in the defense based on the factors of METT-T and considers the following:
 - (1) **Dispersion.** Units and weapons are dispersed laterally and in depth to reduce the enemy's ability to suppress, and to hit the enemy from multiple directions.
 - (2) **Cover and concealment.** Elements are placed in positions where cover and concealment are available; obvious terrain is avoided. Hide positions are used. A technique to check the adequacy of concealment is to travel approaches from the enemy's direction of movement. Covered routes must be available to allow movement in and between positions and for maneuver against the enemy.
 - (3) **Flanking fire.** Flanking fires are far more effective than frontal fires. Initial positioning of antiarmor weapons for long-range engagements is considered, but primary positions are normally picked to allow flanking fires from defilade positions.
 - (4) **Security.** Position security must include patrolling, OPs, and other measures to provide security. Scouts may be augmented to perform counterreconnaissance tasks or company teams may be given security missions forward of the FEBA.
 - (5) **Ability to maneuver.** Units must be able to concentrate on the avenues of approach being used by the enemy. To do this, on-order positions with sectors of fire and positions in depth are used.
 - (6) **Range of weapons systems.** When selecting tentative positions for weapons systems, the task force commander

must also consider the effective range and acquisition capabilities of each system. Tanks are positioned to begin engagement of enemy tanks at 2,500 meters. ITVs engage tanks out to 3,750 meters (3,000 preferred). GLLDs with their long-range designation capability (3,000 to 5,000 meters for moving or stationary targets respectively) and their requirement to be within 800 roils of the gun-target line may compete with ITVs for positioning. The BFV's 25-mm gun is effective against BMPs, BTRs, and BRDMs with a planning range of 1,700 meters. Dragons allow infantry to defeat flanked armor at ranges up to 1,000 (800 preferred) meters and light antitank weapons at ranges of 200 meters (150 preferred). Attack helicopters in an antitank role have a maximum range of 3,750 meters for the AH-1S and 5,000 meters for the AH-64. The commander considers these capabilities when selecting engagement areas, positioning obstacles, designing his defense, and issuing his engagement and withdrawal criteria.

- (7) **Transition to limited visibility fighting positions.** An attacker uses smoke and suppressive fire to limit visibility. The defenders must anticipate and be prepared to move rapidly to predetermined, limited visibility fighting positions.
- (8) **Subordinate missions.** The task force commander sets his scheme of maneuver into motion by assigning missions to company teams. He task-organizes to give each team the required assets. He allocates space using sectors, battle positions, and strongpoints, and gives specific tasks for each. Engagement areas, TRPs, terrain that must be held, and counterattack missions are also included as required. The task force commander states whether his company teams may accept decisive engagement. When explaining his concept, the task force commander states disengagement criteria. He informs each company team commander of the conditions under which to disengage (for example, when the enemy reaches a point on the ground, or after destroying a certain number of vehicles, or at a certain time or event, or do not disengage until ordered to do so).
 - (a) In assigning a mission of holding terrain, the task force commander considers that significant time is required to hold a battle position and that more time and resources are required for a strongpoint. Infantry-pure companies or infantry-heavy teams are best suited for retain missions.

- (b) If there are more missions than combat elements available to perform them, a reserve may be designated and tasked to perform these missions on order.
 - (c) When assigning space, the task force commander ensures that company teams have room to position weapons and to disperse from enemy direct and indirect fires and observation. In relatively open terrain, the distance between ITVs, BFVs, and tanks should be about 150 meters. The commander must consider space requirements for alternate and supplementary positions when he allocates space.
 - (d) Subordinates must know how the battle is to be fought and what their roles are to be. This includes knowledge of fire control measures (TRPs, EAs), areas to be covered by fire, requirements for obstacle emplacement, security, and on-order missions in priority.
 - (e) The defense plans include the rapid maneuver of forces to attack the enemy's flanks and rear. Maneuver also serves to confuse the attacker, as when a unit moves from a position occupied initially with no intent to fight from it. The task force commander must plan and rehearse maneuver to the extent that time allows.
- c. Tanks are a key element in counterattacks. They can fire on the move and have a faster rate of fire and shorter engagement time than missiles. Tanks should be used to cover the most dangerous armor avenues of approach, and the reserve force should be built around tanks.
- d. Antitank missiles provide long-range fires but are limited by rate of fire and time of flight. They are positioned to maximize their standoff capacity, normally from flanking positions into relatively open areas that allow tracking. They may also be used as "sniper" weapons for destroying enemy reconnaissance or advance guard elements from alternate and supplemental positions without disclosing the defender's primary positions. ITVs should be employed in mass (in at least platoon strength) to maximize their effectiveness.
- e. BFVs are used to provide TOW and 25-mm fires, but the need to keep them accessible to dismounted elements must be considered. The highly mobile BFV should be positioned to kill BMPs both from defensive positions and in counterattacks. The scheme of maneuver should enhance the standoff, maneuverability, and night fighting advantage of the BFV over the BMP.

- f. In defensive operations, the commander attempts to maximize the combat power of both the BFV and dismounted elements. Dismounted infantry defensive positions are selected to —
- Defend positions against enemy infantry attack.
 - Provide security and gather intelligence by patrolling and establishing OPs, antiarmor ambushes, and roadblocks on secondary approaches.
 - Emplace, close, and defend obstacles.
 - Ambush and or destroy enemy armored vehicles with handheld antitank weapons.
 - Clear fields of fire.
- g. Battle positions for dismounted infantry are chosen to hold, or deny, mounted and dismounted avenues of approach to key terrain. Positioning dismounted infantry on forward slopes may needlessly expose them to long-range direct and observed indirect fires. Positions well forward, to the flanks, or on reverse slopes that deny approaches to key decisive terrain avoid exposing dismounted infantry and provide cover and concealment. Dismounted infantry is best suited for close-in fighting on restrictive terrain with limited fields of fire. Dismounted infantry should be positioned so they can only be threatened inside the ranges of their antitank weapons.
- h. When good infantry terrain is not available, but the terrain must be held and armor defeated, the infantry must have time to construct obstacles and strong fighting positions. This time factor must be considered in assigning on-order and subsequent battle positions to infantry. BFVs may be positioned on the forward slope, then displaced to positions on the flanks to overwatch the rear of the dismounted elements, where they can support by fire. BFVs may also be assigned separate sectors of fire. When separated from their dismounted infantry, BFVs must have routes that allow the elements to rejoin. These routes should be reconnoitered for day and night linkup.
- i. Based on the TF reconnaissance and security plan, infantry provides OPs and patrols between battle positions to augment the efforts of the scouts. Infantry can be used to provide manpower for constructing obstacles, clearing fields of fire, securing obstacles, and closing lanes and gaps in obstacles. When assigning infantry additional tasks outside of their battle positions, the time to construct individual positions must be considered.

4-9. COMBAT SUPPORT

a. Fire Support.

(1) Supporting fires are planned and used–

- At long range to disrupt, slow, and disorganize the enemy and force him to button-up.
- On likely enemy overwatch positions.
- To provide illumination.
- To cover disengagement, movements, and counterattacks.
- Along covered avenues of approach to destroy enemy dismounted infantry. Mortars and field artillery are particularly effective against dismounted infantry. FPFs used to destroy assaulting infantry are planned close-in to battle positions and are fired to break the assault.
- To defeat dismounted breaching.
- To provide smoke for disengagement.
- To deliver scatterable mines (FASCAM) on avenues of approach where movement is choked, and to close lanes, gaps, or enemy breaches in obstacles. FASCAM is most effective when tied in with other obstacles and covered by observation and direct fire.
- To suppress enemy forward air defense.

(2) The task force commander develops the fire support concept and tasks concurrently with the scheme of maneuver. The FSO then coordinates with the engineer, mortar platoon leader, FAC, S3 Air, and aviation liaison officer to develop an initial fire plan. This plan is refined based upon input from company commanders and FSOs. The company FSO executes fires. The task force commander and FSO may orchestrate this by establishing an event-oriented scheme of fire support. For example, "When the enemy lead MRC reaches Phase Line Red, Team A will fire target AB4200; when the enemy reaches and attempts to breach the obstacle, Company C will fire target AB4400; if the enemy attempts to bypass on the left, Company D will fire FASCAM at target AB4500."

(3) If the task force is allocated field artillery priority targets, they are planned on the most dangerous enemy avenues of approach. They may be suballocated to units on these

approaches. Priority targets are shifted as the battle develops. The commander also designates priority of fires, normally to the forward security force initially, then to the unit designated as the task force main effort.

b. Mobility, Countermobility, Survivability.

- (1) **Engineers.** The commander establishes an overall priority of engineer tasks to be accomplished. Specific priorities may be further assigned to key pieces of engineer equipment. As an example, bulldozer priority may go to key tank fighting positions (survivability). While engineer squads begin work on obstacles (countermobility) and CEVs, bucket loaders, or back-hoes dig other fighting positions or clear routes between them (mobility). Priority tasks and allocation of engineer assets must support the main effort and work must begin as soon as possible.
 - (a) The task force may provide manpower, additional equipment, and supplies to support the engineer effort.
 - (b) Obstacles support the main effort in the defense. An obstacle is any obstruction that delays, canalizes, or restricts movement or maneuver. Obstacles are grouped into two categories — existing and reinforcing. Considerations in the use of obstacles are —
 - Obstacles are integrated into the scheme of maneuver and used by defending forces to canalize the enemy into areas where he is the most vulnerable to concentrated direct fires and to hold him there as long as possible.
 - Obstacles are planned where they can be observed and covered by direct fire and are designated as indirect fire targets. A specific company team is assigned responsibility for protecting each obstacle. This includes protecting the obstacle during limited visibility, and checking it at first light to ensure that it has not been breached.
 - Point obstacles placed at irregular patterns can be used along secondary restrictive approaches to slow movement. These might not always be covered by direct fire.
 - Emplacement time is reduced and effectiveness increased when obstacles reinforce natural or cultural obstacles. Each individual obstacle must be carefully designed for the location it will occupy, and must

overlap on each side with the existing obstacle it will complete. The critical width of an obstacle is the distance from an existing obstacle to another existing obstacle (or to another reinforcing obstacle), and not the width of a road or highway through the existing obstacle.

- Obstacles must not hinder friendly movement. Lanes and gaps through obstacles may be needed to allow movement. If so, a plan must prescribe who closes the lane or gap, the criteria, the signal, and when and where to report the closure. Company team commanders usually control and close gaps and lanes in their areas.
- Obstacles are employed in depth. Obstacles must be far enough apart so that each one will require a new deployment of the enemy's counterobstacle force and equipment.
- Hasty protective minefields are used for short periods or for specific missions. They can be laid by company teams without regard to any standard pattern or density. Mines must be readily detectable and removable by the installing unit. Normally, mines carried on fighting vehicles are used for hasty protective minefield.
- Obstacles are emplaced to surprise the enemy. Security forces must be forward to deter enemy observation of obstacle construction. Obstacles should be in defilade and camouflaged if possible.
- Dummy obstacles can be used to confuse the enemy.
- The exact position of obstacles is coordinated between the engineer, company team commander, and the FSO to ensure adequate coverage. Since planned obstacle sites are often adjusted on the ground to accommodate direct fire coverage, the FSO must reconfirm target locations after obstacles are emplaced.
- In addition to siting obstacles to increase the effectiveness of direct fires, the commander maximizes the effectiveness of the obstacles by use of indirect fire support.
 - Smoke can be used to conceal the location of obstacles.

- FASCAM, planned by engineers, can be used to cut escape routes or reinforce obstacles already in place.
 - FA and mortars can slow or stop dismounted breaching efforts.
- (c) If covered routes out of and into battle positions are not available, these may receive a priority as well. Emphasis is on improving or maintaining existing routes rather than constructing new ones. Selective cutting in forests can provide an umbrella over the routes to keep them from being seen from the air.
- (d) Protective positions for infantry and dismounted TOWs are constructed using available material that will support at least 18 inches of sandbags, rock, or dirt on top. This will protect against shrapnel from air bursts, but not direct hits. Fighting positions for vehicles are constructed with both hull-down and turret-down locations. Berms are not created since the freshly dug ground can be easily detected, and berms are not effective against kinetic energy rounds. Hull-down vehicle fighting positions take about one hour to complete, depending upon the type of soil. (Turret defilade positions take about two hours to construct and a two-step hide position requires about three hours.)
- (2) **NBC.** NBC operations in the defense concentrate on survivability. Rehearsals are conducted in full MOPP. Plans are made for employment of smoke (see Chapter 6) and to counter enemy use of smoke.
- a. **Air Defense Artillery.** During preparation of the defense, ADA priority normally goes to units preparing positions and obstacles. Once the defensive positions are prepared, priority goes to the main CP, combat trains, and UMCP. When maneuver is required, priority shifts to the maneuvering elements. In each situation, air defense assets focus on the main air avenue of approach.

4-10. ADDITIONAL CONSIDERATIONS

a. Security.

- (1) The task force must locate and destroy the enemy reconnaissance elements early. The enemy's ability to bring overwhelming force against friendly defenses is directly tied to the effectiveness of his reconnaissance elements.

- (2) Forward security is positioned based on IPB. Where necessary, security elements may be strengthened by allocating additional forces to them. For example, a tank platoon with its tank thermal sight (TTS) capability and additional firepower can be attached to the TF scout platoon at night.

b. Defensive Control Measures.

- (1) Fire control measures are used to help the task force commander to mass fires on the enemy while distributing them to avoid target overkill. Combined with a well-planned obstacle system, they allow the defender to fully exploit the effects of organic and supporting weapons. Techniques for controlling task force fires are —

- (a) **Target reference point.** A TRP is an easily recognizable point on the ground, either natural or man-made, used for identifying targets and controlling direct and indirect fires (see Figure 4-3). TRPs are designated to rapidly distribute or mass fires. A TRP is designated using a standard target symbol and target number issued either by the FSO or IAW SOP. Once designated, TRPs also constitute indirect fire targets. TRPs should be placed on each major obstacle to ensure that it is covered by both direct and indirect fires. This results in the obstacle and the direct and indirect fire targets all having the same number. TRPs should be planned on likely enemy locations and obstacles. They may also be used to clearly define engagement areas or to mark engagement and disengagement ranges. Weapons will be engaging from different directions, so compass points (north, east), rather than right or left, are used when giving directions centered on a TRP.

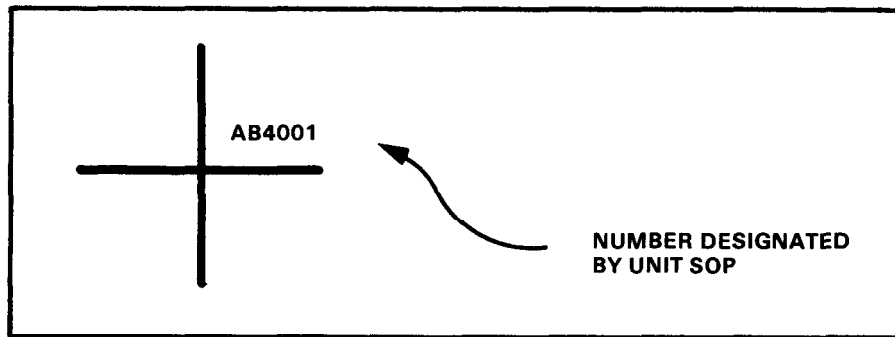

Figure 4-3. Target reference point.

- (b) **Engagement priority.** Fire can be rapidly and effectively distributed by assigning each weapon or section a type of vehicle to engage first; for example, BFVs engage BMPs; tanks or ITVs engage tanks. The most dangerous targets are shot first then targets in depth.
- (c) **Trigger line.** A fire control measure related to terrain (roads or streams), obstacles, or weapons capabilities that initiates fire when crossed by the enemy.
- (d) **Sector of fire.** A specific area can be assigned to a unit or a weapon. Each unit should be assigned one primary sector and an on-order or secondary sector of fire. If no targets appear in its primary sector, it engages targets in its secondary sector. (See Figure 4-4.)

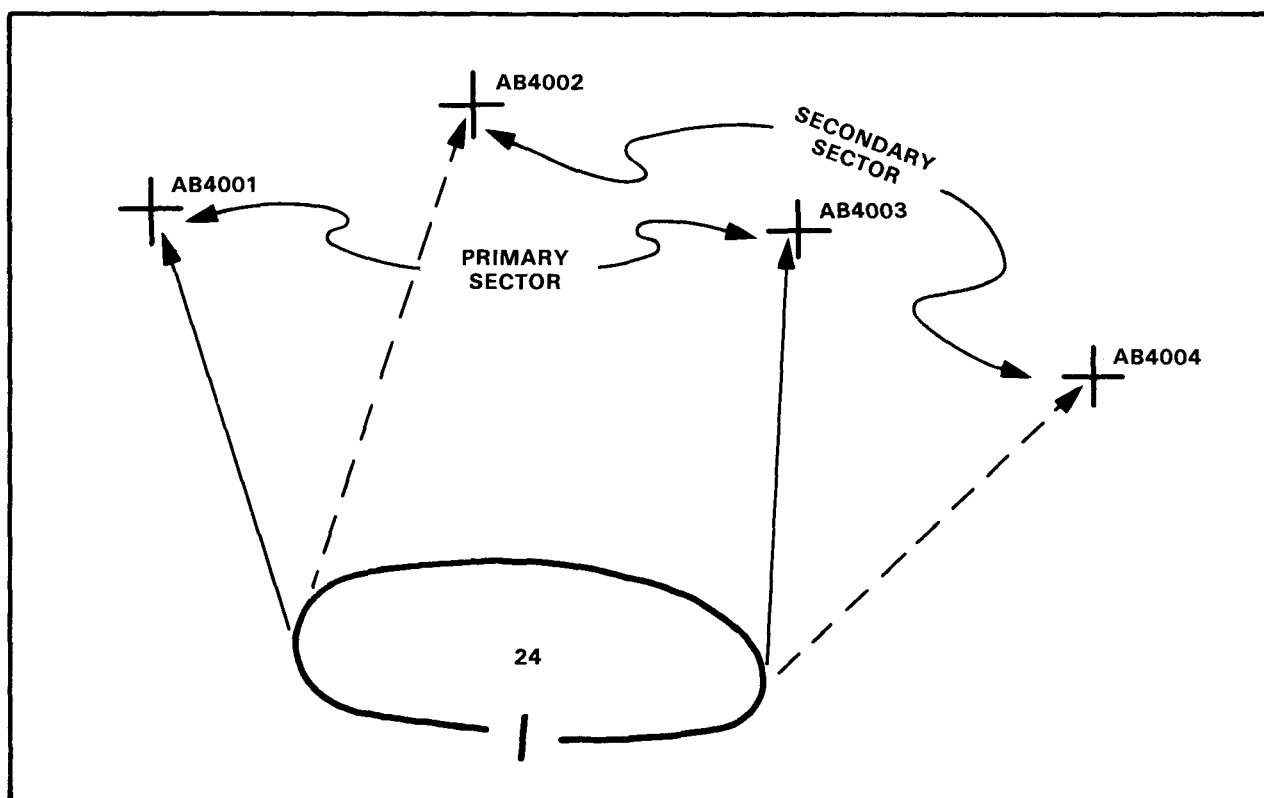

Figure 4-4. Sector of fire.

- (e) **Engagement area.** Engagement areas (Figure 4-5, page 4-22) may be designated by the task force or company team commanders along enemy avenues of

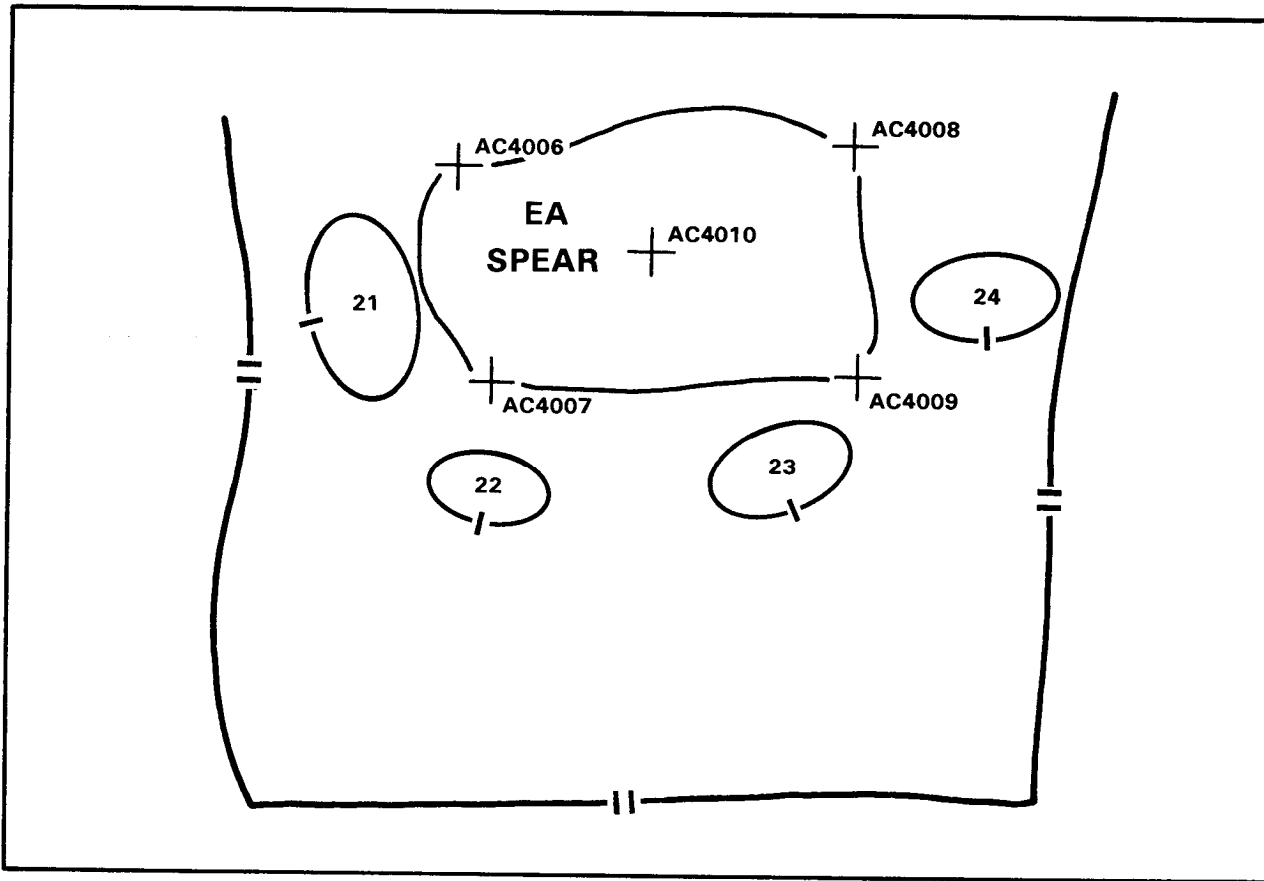

Figure 4-5. Engagement area.

approach. They are areas in which the commander intends to destroy an enemy force with massed fires. An engagement area can be identified by prominent terrain features around the area or by a TRP at the corners of the area. The area may be divided into sectors. The commander must provide guidance on the timing necessary to initiate fires. Distances can be marked by TRPs.

- (2) Maneuver control measures normally used by the battalion task force are —
- Coordinating points.
 - Phase lines.
 - Battle positions or sectors.
 - Contact points.

- Passage points.
- Passage lanes.
- Routes.
- M S R .
- Checkpoints.
- Assembly areas.

c. Limited Visibility.

- (1) Normally, the task force commander can expect an attacker to use limited visibility conditions to —
 - Reconnoiter to locate the defender's weapons, obstacles, and positions.
 - Move assault overwatch elements into position.
 - Infiltrate infantry.
 - Breach obstacles.
 - Move elements through gaps in the defender's coverage caused by reduced ranges of weapons.
- (2) Defending during limited visibility, especially at night, will be a normal condition. The defender must be able to rapidly modify the defense to negate the impact of limited visibility on the operation.
- (3) The task force must establish signals that initiate direct and indirect fire engagements, lift and shift fires, and initiate movement.
- (4) The following steps are planning considerations for limited visibility operations:
 - (a) Use long-range detection equipment (radar, sensors, night observation devices) on well-defined avenues of approach.
 - (b) Increase surveillance of obstacles, potential enemy overwatch and assault positions, and routes into them.
 - (c) Redeploy some units and weapons along avenues of approach that the enemy will likely use during limited visibility.
 - (d) Use more infantry, scouts, OPs, patrols, and armor-killer teams forward on secondary avenues of approach and between positions to detect and slow enemy infiltration.

- (e) Use point obstacles and early warning devices along likely night approaches to slow the enemy and to alert defenders to enemy presence.
- (f) Plan and rehearse the required movement of weapons and units and the massing of fires.
- (g) Plan illumination on or behind likely engagement areas to silhouette enemy forces while leaving defenders in shadows and darkness. While illumination is not needed with thermal sights, it may be needed for dismounted infantry.
- (h) Movement tonight defensive positions should begin just before dark, and the return to daylight positions should be completed before dawn.

4-11. SYNCHRONIZATION OF DEFENSIVE OPERATIONS

The success of the defense is determined by how effectively all supporting organizations are integrated into the maneuver plan. This section describes the general defensive roles, missions, and priorities of supporting organizations.

- a. **Maneuver.** The task force commander arrays company or team-size forces against battalion-sized avenues of approach. Against armored attacks, the defense is organized around weapon systems that can maneuver and destroy the enemy.
 - (1) **Scout platoon.** During the defense, the scout platoon's initial mission is to coordinate the battle handover of covering force units and facilitate their orderly movement through the battalion defensive sector as battle positions. Concurrently with this mission, the scouts identify the main effort of the enemy moving into the battalion task force sector. Subsequent missions include screening missions of flank avenues of approach and maintaining contact with adjacent units.
 - (2) **Antitank.** Antitank units are employed in mass during defensive operations. Antitank units add depth to the defensive fight by being positioned to the rear of the main defensive forces to cover and support by fire. The maneuver of forward company teams positioning should allow for engagement of the enemy from the flank and rear.
 - (3) **Attack helicopters.** When brigade employs an attack helicopter battalion, it is usually used to cover gaps, to attack

by fire against penetrations, to provide overwatch for counterattacking forces, or to attack enemy second echelon formations.

b. Fire Support.

(1) **Field artillery.** Field artillery is positioned by brigade to support both the battalion close fight and brigade deep fight. Task force priority targets are planned on the most dangerous enemy avenues of approach. They are then suballocated to units on those approaches and shifted as the battle develops. Priority of fires is initially to the forward security element during battle handover; on order, it shifts to the unit designated the main effort.

* (2) **Mortars.** The battalion mortars should cover the most probable dismounted enemy avenue of approach or the battalion's most critical obstacle.

(3) **Air Force.** CAS targets are preplanned to support the full depth of the battlefield and the transition to the offense.

c. Intelligence.

(1) **GSR.** In the defense, GSRs are positioned well forward to participate in the early identification of enemy reconnaissance units and confirm enemy movement within NAIs and TAIs. GSRs are most effective in these roles during limited visibility. Subsequent missions include observation of flank avenues of approach and vectoring of the reserve company/team in support of a night operation mission.

(2) **Other.** Aviation or ground units performing reconnaissance or security missions forward of the task force also provide valuable intelligence.

d. **Air Defense Artillery.** ADA assets are initially positioned well forward to provide area coverage in support of the defensive preparations, the battle handover operation, and the initial enemy attack. Subsequent employment is area coverage throughout the battlefield with priority to counterattacking forces, choke points, river crossing sites, and other potential high payoff enemy air targets.

e. Mobility, Countermobility, Survivability.

(1) **Engineer.** Priority of engineer support is normally to survivability, countermobility, then mobility. The engineer assists initially in planning and emplacing obstacles to support its countermobility mission.

(2) **NBC.** NBC operations in the defense concentrate on survivability. Smoke is employed in mobility and countermobility roles.

f. Combat Service Support

(1) **Combat trains.** The combat trains are as far to the rear as possible but close enough to be responsive to maneuver units. Combat trains may be required to move frequently to support defensive operations. Combat trains operations are organized to provide continuous support but not interfere with maneuver elements.

- (2) **Support platoon.** Before defensive operations, the support platoon brings forward barrier material. During defensive operations, the support platoon's priority of support is to Class III and V.

4-12. SEQUENCE OF THE DEFENSE

A defense will often be conducted in the following sequence of events:

- a. **Occupation.** During this phase, the scouts are usually the first to clear the proposed defensive position. They check for enemy OPs and NBC contamination. Leaders then reconnoiter and prepare their assigned areas. Security is established forward of the defense area to allow occupation of positions and preparation of obstacles without compromise. During occupations, movement is minimized to avoid enemy observation.
- b. **Passage of the Covering Force.** The task force establishes contact with, and assists the disengagement and passage of the covering force or other security elements. (Passage of lines is discussed in Chapter 5.)
- c. **Defeat of Enemy Reconnaissance Infiltration, and Preparatory Fires.** Consistent with security requirements, task force elements remain in defilade, hide, and prepared positions to avoid the casualties and shock associated with indirect fires. The enemy will attempt to discover the defensive scheme by reconnaissance and probing attacks of the advance guard. The enemy may also attempt to infiltrate infantry to disrupt the defense or to breach obstacles. Task force security forces must defeat these efforts using maneuver and fires.
- d. **Approach of the Enemy Main Attack.** Task force security elements observe and report enemy approach movement. The task force commander repositions or reorients his forces to mass against the enemy's main effort. Enemy formations are engaged

at maximum range by supporting fires and close air support to cause casualties, to slow and disorganize him, to cause him to button up, and to impair his communications. Obstacles are closed. Direct fire weapons are repositioned as required, or maneuvered to attack the enemy from the flank. The task force commander may initially withhold fires to allow the enemy to close into an engagement area so that at the decisive time he can concentrate fires on the enemy formation.

- e. **Enemy Assault.** As the enemy deploys, he becomes increasingly vulnerable to obstacles. The task force uses a combination of obstacles, blocking positions, and fires to breakup the assaulting formation. Continued maneuver to enemy flanks and rear is used to destroy him and to increase the number of directions to which he must react. Some security elements may stay in forward positions to monitor enemy second-echelon movement and to direct supporting fires on these forces as well as on his artillery, air defense, supply, and command and control elements.
- f. **Counterattack.** As the enemy assault is slowed or stopped, the task force commander will launch his counterattack (by fire or by maneuver) to complete the destruction of the enemy forces.
- g. **Reorganization and Consolidation.** The task force must quickly reorganize to continue the defense. Attacks are made to destroy enemy remnants, casualties are evacuated, and units are shifted and reorganized to respond to losses. Ammunition and other critical items are cross-leveled and resupplied. Security and obstacles are reestablished and reports are submitted.

4-13. BATTLE HANDOVER

- a. As the covering force moves to the rear, the task force commander prepares for the battle handover. The handover is the transition from the CFA battle to the MBA battle in which the MBA forces begin to engage the enemy.
- b. The battle handover is an important function in a coordinated defense because it provides assistance to the CF units near the FEBA, allowing them to disengage without excessive losses so that they can reform and fight again.
- c. The difficulty inherent in the battle handover arises from when, where, and how the CF gives up responsibility for the fight and the MBA task force takes over. The battle handover line and contact points on the ground must be coordinated and clearly identifiable to both forces.

- d. The headquarters that establishes the CF designates the battle handover line and establishes contact points to facilitate contact between MBA units and CFA units (see Figure 4-6). MBA and CFA commanders coordinate and recommend any changes in location of the handover line to the higher commander. The handover line is shown on the operation overlay as a phase line. It is the CFA rear boundary unless otherwise stated. The handover line delineates the location where control of the battle will be passed from the CFA to the MBA commander. It is typically 2 to 4 kilometers forward of the FEBA where MBA forces can use direct fires and observed indirect fire to assist the covering force in its final delay, disengagement, withdrawal, and rearward passage of lines. The battle handover takes place at the time or event coordinated between the commanders or as directed by the senior commander. (See Chapter 5 for a full discussion of passage of lines.)

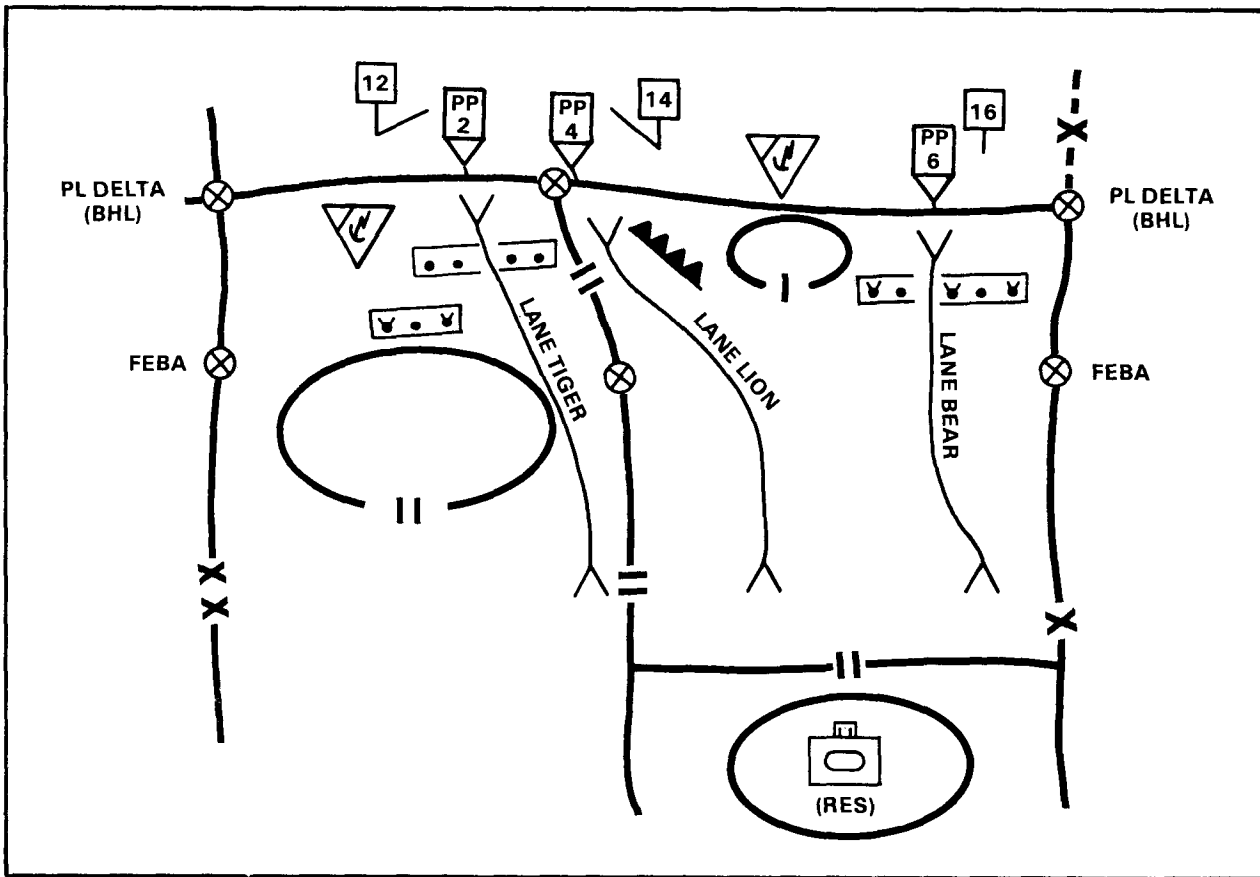

Figure 4-6. Battle handover line.

- e. The task force commander defending in the MBA positions security forces between the FEBA and the handover line (see Figure 4-7). Security forces perform security operations for the MBA as part of the commander's overall surveillance, counter-reconnaissance, and deception effort. Additionally, elements from the security force man the contact points forward of the handover line.

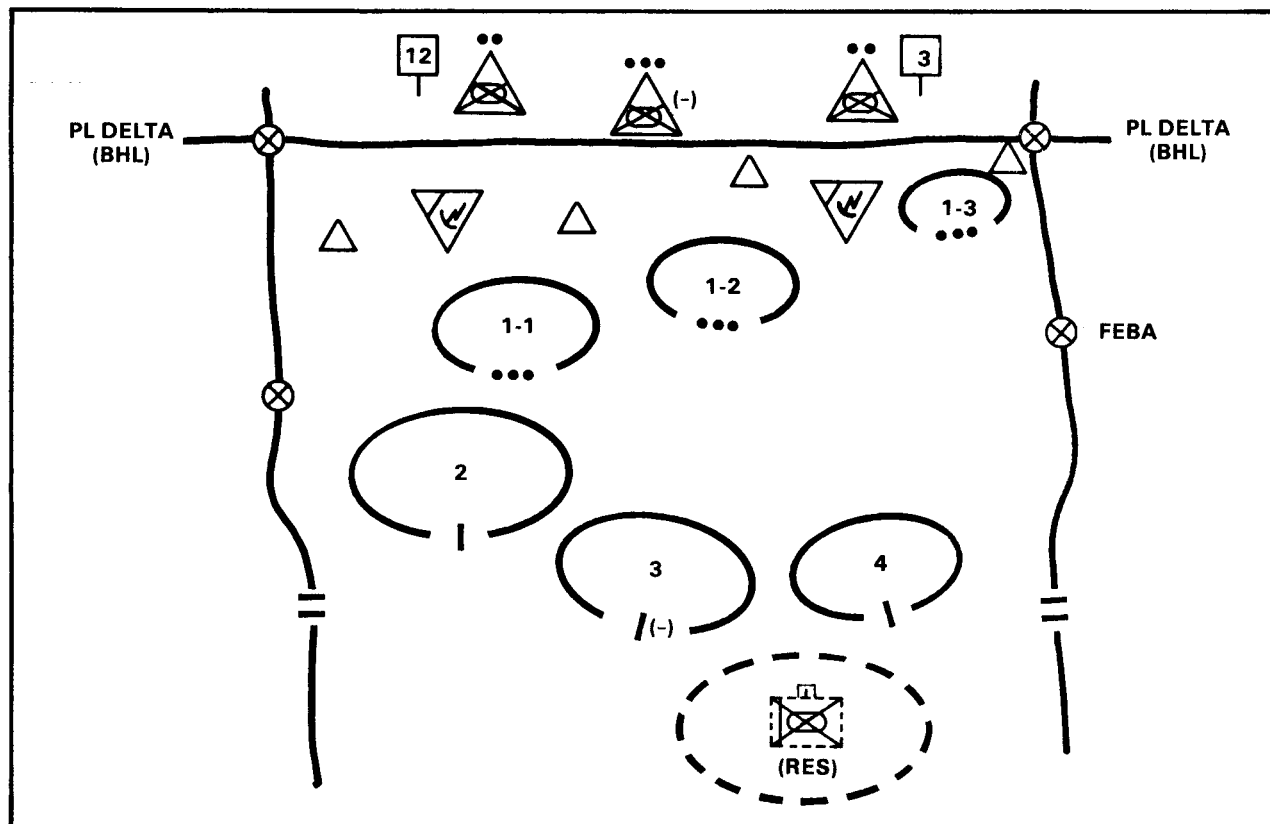

Figure 4-7. Security forces forward.

- f. The security forces —
- Assist the passage of the covering force at the handover line and assist in CF disengagement.
 - Gain and maintain contact with enemy forces as the battle handover occurs.
 - Locate and destroy enemy reconnaissance elements to preclude enemy observation of primary defensive positions.
 - Close gaps and lanes in forward obstacles as the CF withdraws.

Section IV. TYPES OF DEFENSE

The battalion task force will normally defend using three basic types of defense. They are defend in sector, defend a battle position, and defend a stongpoint. Figure 4-8 summarizes the factors a commander considers in selecting a battle position versus a sector.

FACTOR	BATTLE POSITION	SECTOR
Avenues of approach	Well defined; enemy can be canalized	Multiple avenues prohibit concentration
Terrain	Dominates avenues of approach	Dominating terrain not available
Area of operations	Narrow	Wide
Mutual support between companies	Achievable	Cannot be achieved
Higher commander's ability to control	Good	Degraded

Figure 4-8. Defending from battle positions versus sectors.

4-14. DEFENSE OF A SECTOR

- a. A defensive sector is an area designated by boundaries that define where a unit operates and the terrain for which it is responsible. Defense in sector is the most common defense mission for the task force.
- b. Sectors may be used in both the MBA and CFA. Sector boundaries never split an avenue of approach. Task force sectors are oriented on regimental avenues of approach and are used when the brigade commander wishes to allow maximum freedom of action to his task forces. Sectors are generally deeper than they are wide to permit the defending unit to fight the battle in depth and to provide sufficient space for CSS assets. A commander defending a sector is expected to defeat enemy forces within his sector, and maintain his flank security.
- c. Defend in sector is the least restrictive mission. It allows the task force commander to plan and execute his defense using

whatever technique is necessary to accomplish the mission. He may use sectors, battle positions, strongpoints, or a combination of measures to accomplish his mission.

- d. A defense in sector requires the task force commander to —
- Allocate maneuver space by designating sectors, battle positions, or strongpoints.
 - Control direct fires using engagement areas, TRPs, and phase lines.
 - Integrate obstacles, fire support, and air defense into the maneuver plan.
 - Position security forces forward of the FEBA, and to the flanks and rear as necessary, and maintain coordination with flank units.
 - Consider the effect of limited visibility. For example, he may move forces forward to cover TRPs, adjust TRPs closer to battle positions, or designate on-order positions closer to the engagement area.
 - Define limits of subordinate action to include engagement and disengagement criteria and counterattacks.
 - Set priorities for movement on routes during repositioning, disengagement, or counterattacks.
- e. If the commander cannot concentrate fires, he distributes his forces and fires using company sectors. For example, in Figure 4-9 (page 4-32), the commander used three companies in sector because multiple avenues of approach promoted decentralization. The reserve is positioned near where it probably will be used, and the reserve force commander prepares and reconnoiters routes to on-order counterattack positions.
- (1) To control his forces, the task force commander establishes coordinating points, phase lines, on-order battle positions, and contact points.
 - (2) The following scenario illustrates the tactics and techniques inherent in conducting a defense in sector. In Figure 4-10, (page 4-32), the commander has established coordinating points for control along the FEBA. His intent is to destroy the enemy force forward in the MBA. As an initial step, he has established a security force consisting of a reinforced mechanized infantry company to provide early warning, conduct counterreconnaissance, and assist the rearward passage and battle handover of the covering force. The task

force commander has also added phase lines, on-order positions, and contact points to facilitate his control of the battle as it progresses.

- (3) As the battle develops, the security force identifies the main effort against the middle company sector. The enemy's attack is initially blunted by the company defending this sector, which causes the enemy to lose his momentum. The left flank team commander sees an opportunity to counterattack from the flank to destroy the enemy force (see Figure 4-11). Taking this initiative is within the battle framework established by the task force commander's intent. The team commander is authorized to attack if an opportunity presents itself. The team commander informs the commander of his intended action so that the task force commander can adjust elsewhere on the battlefield and preserve unity of effort. The task force commander moves to a position to see the counterattack.
- (4) The commander may compensate for changes in the battle by moving the reserve positioned in depth forward to assume responsibility for the vacant sector. Following the counterattack, he may then direct the counterattack force to conduct a rearward passage and occupy positions in depth to become the reserve.

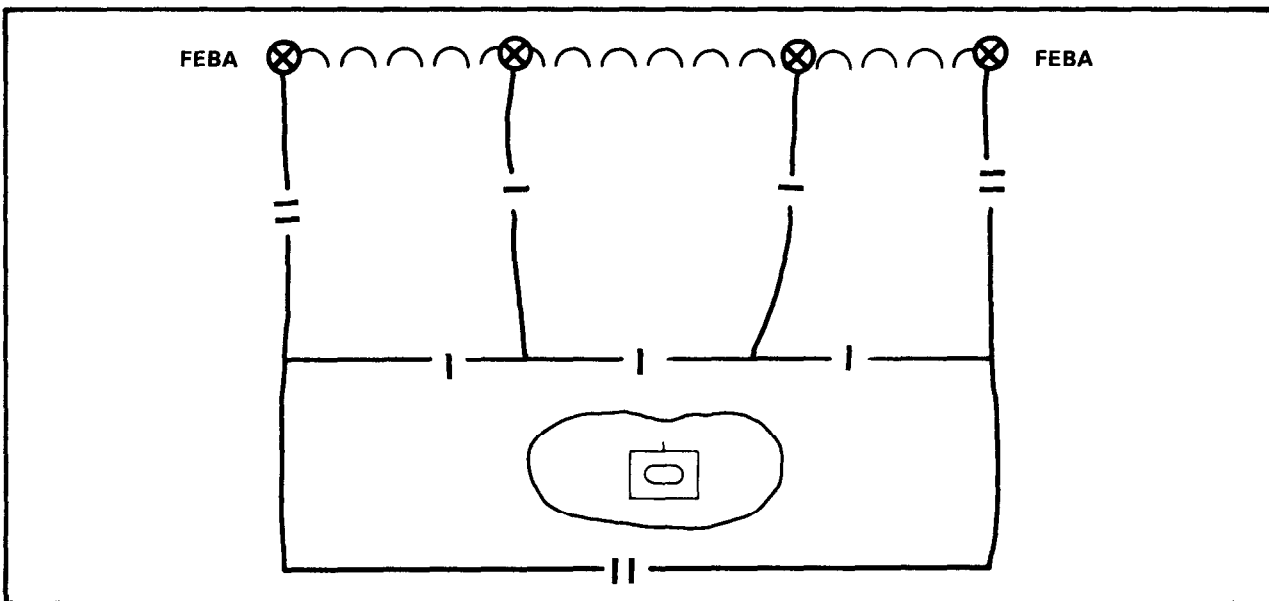

Figure 4-9. Battalion with three company teams in sector and a company in reserve.

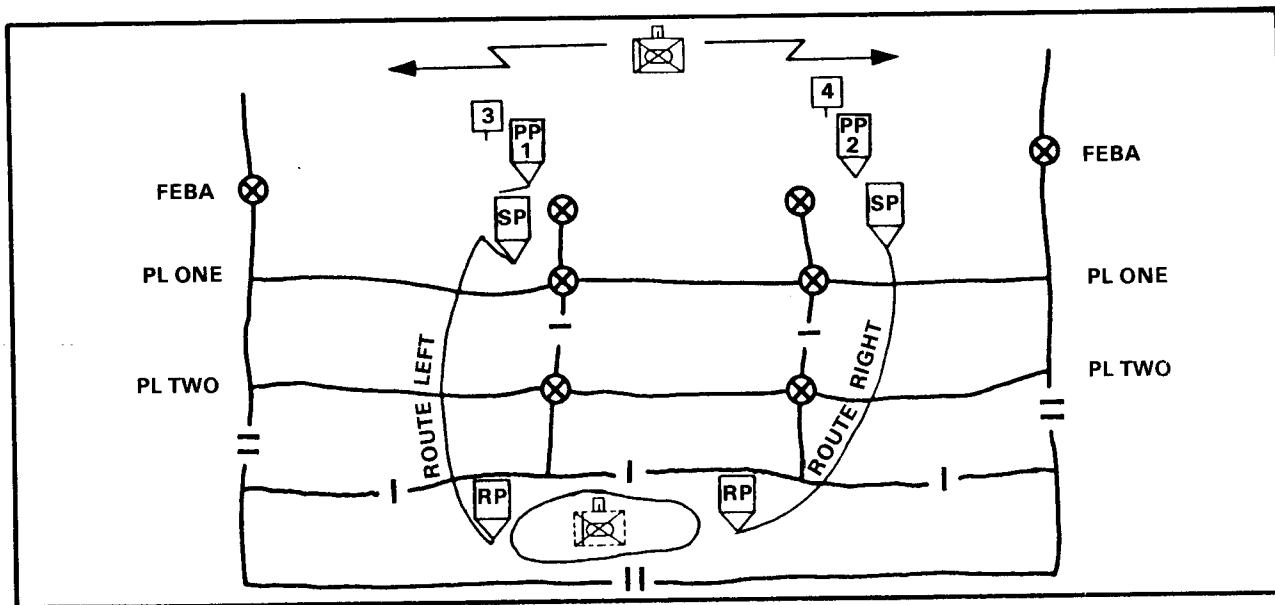

Figure 4-10. Company team sectors with control and coordination measures.

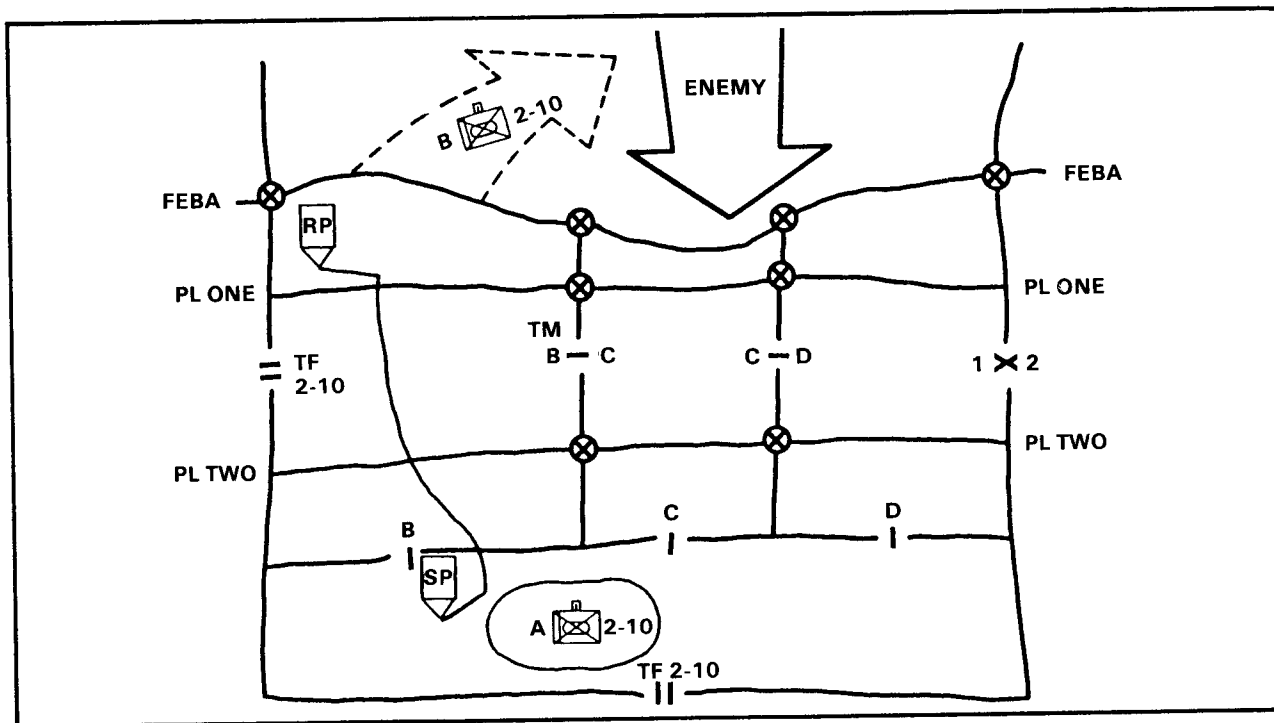

Figure 4-11. Task force counterattack.

- f. As depicted in Figure 4-12, the commander may choose to employ companies in battle positions. This technique restricts maneuver and complicates flank coordination by the companies, but it gives greater control of the overall defense to the task force commander. The use of on-order battle positions with the associated tasks of prepare or reconnoiter provides flexibility and depth to the defensive plan.
- g. There are many combinations of techniques that the commander could use to position his forces. The examples presented here show some of the possible combinations and conditions that could exist.

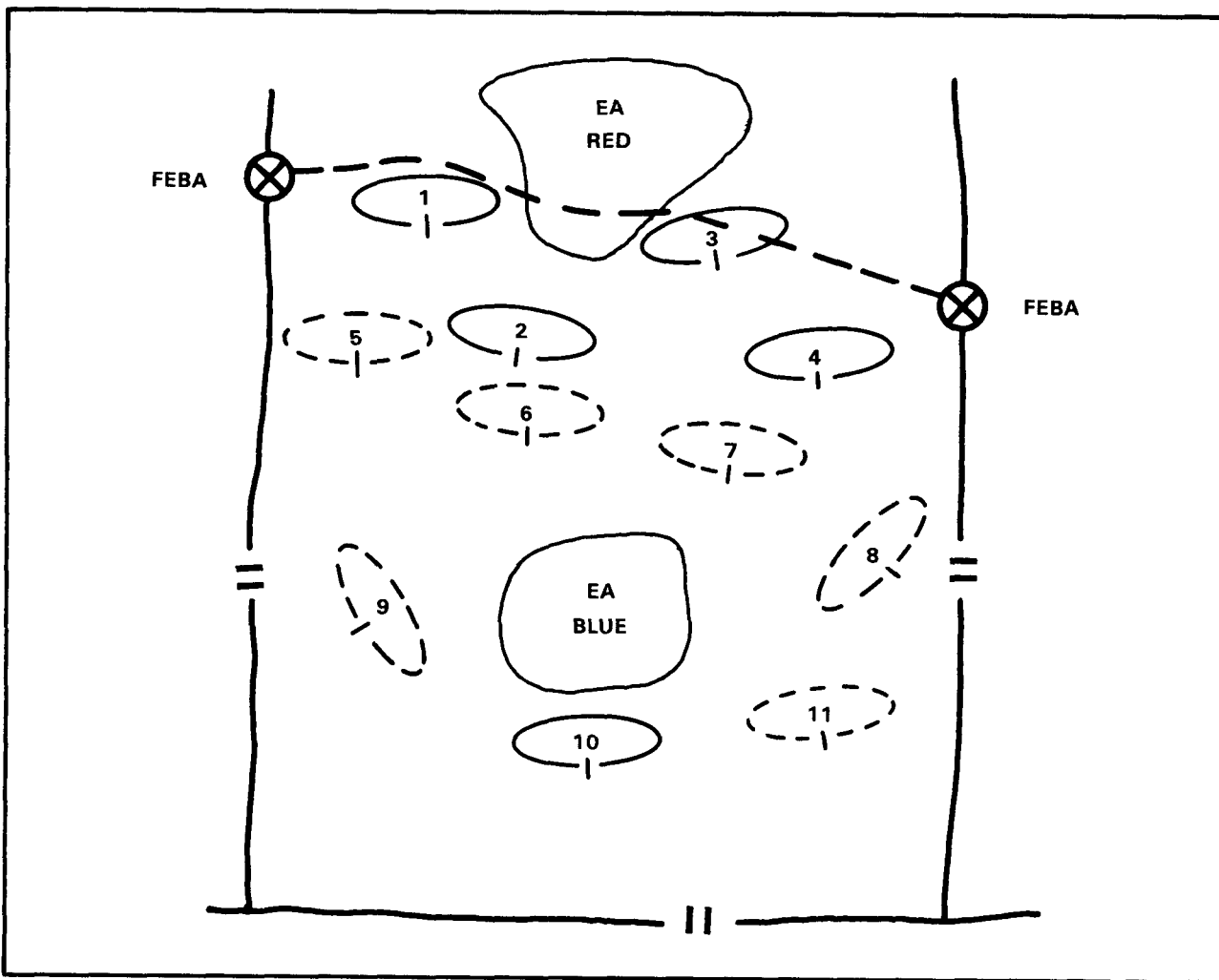

Figure 4-12. Company battle positions.

(1) When the situation calls for maximum flexibility, the commander could initially designate sectors. This case applies where the terrain forward of the FEBA is relatively open while that behind the FEBA is wooded and restrictive. Referring to Figure 4-13, the battalion commander may initially employ his TOWs, tanks, and BFVs from the wood line, using hide positions until the enemy can be engaged. Dismounted infantry could cover both mounted and dismounted avenues of approach at choke points along PL BLUE where enemy tanks and BMPs lose their mobility and firepower-range advantage. As the enemy is stopped or stalled in the woods, he can be destroyed there or on the far side. Where terrain forward of the FEBA is open, only mounted elements may be needed for the security force.

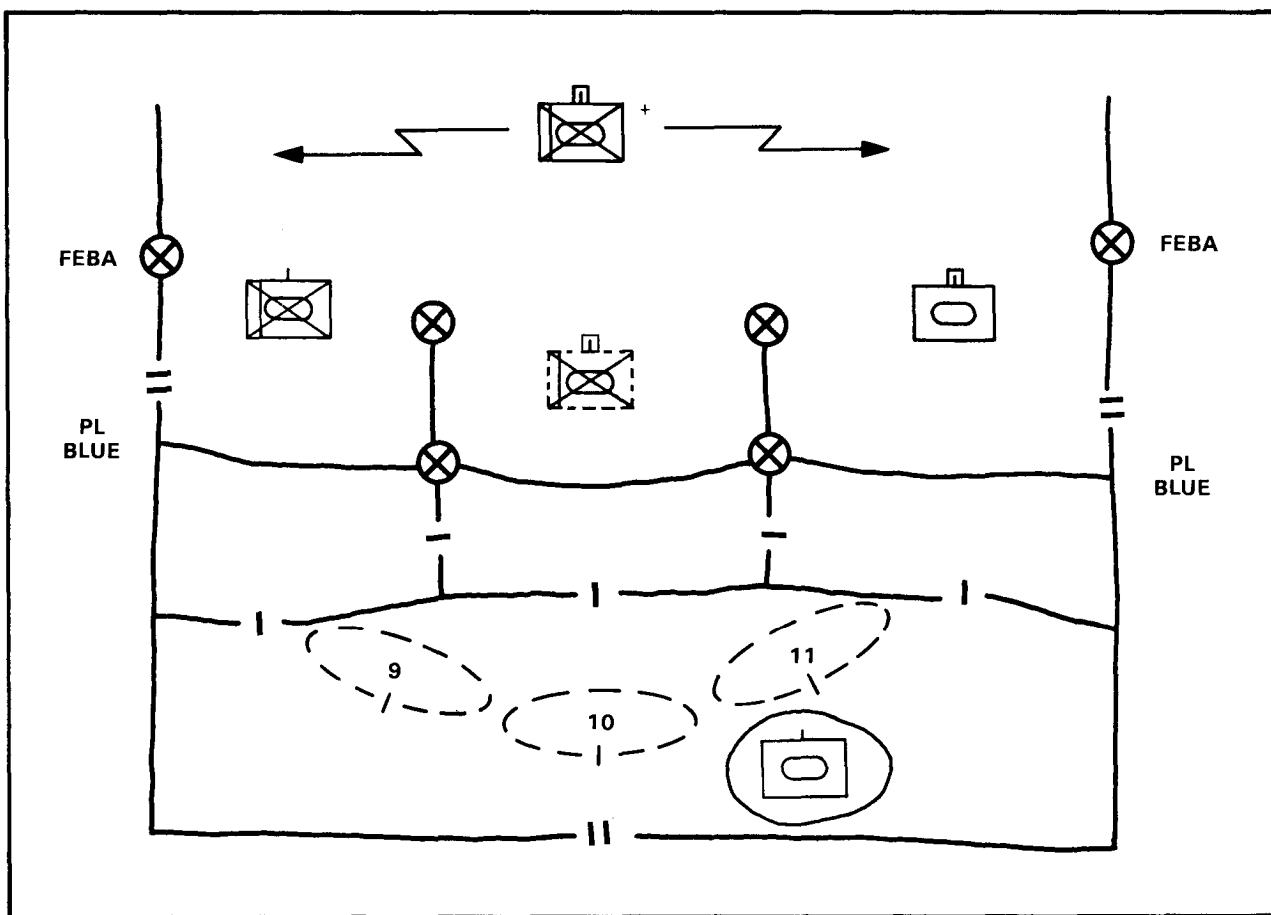

Figure 4-13. Company sectors forward.

Dismounted elements can remain in sector preparing their positions. When the avenue of approach clearly indicates areas where the commander can concentrate the fires of more than one company, he would use battle positions. In the example in Figure 4-13, the commander has found that most enemy avenues in his sector converge forward of BPs 9, 10, and 11, and he plans to directly control that portion of the battle.

- (2) When the commander can identify a piece of terrain around which the battle can pivot, he may choose to create a strongpoint. In the example in Figure 4-14, this technique is most often employed using battle positions, but it can also be used with sectors.

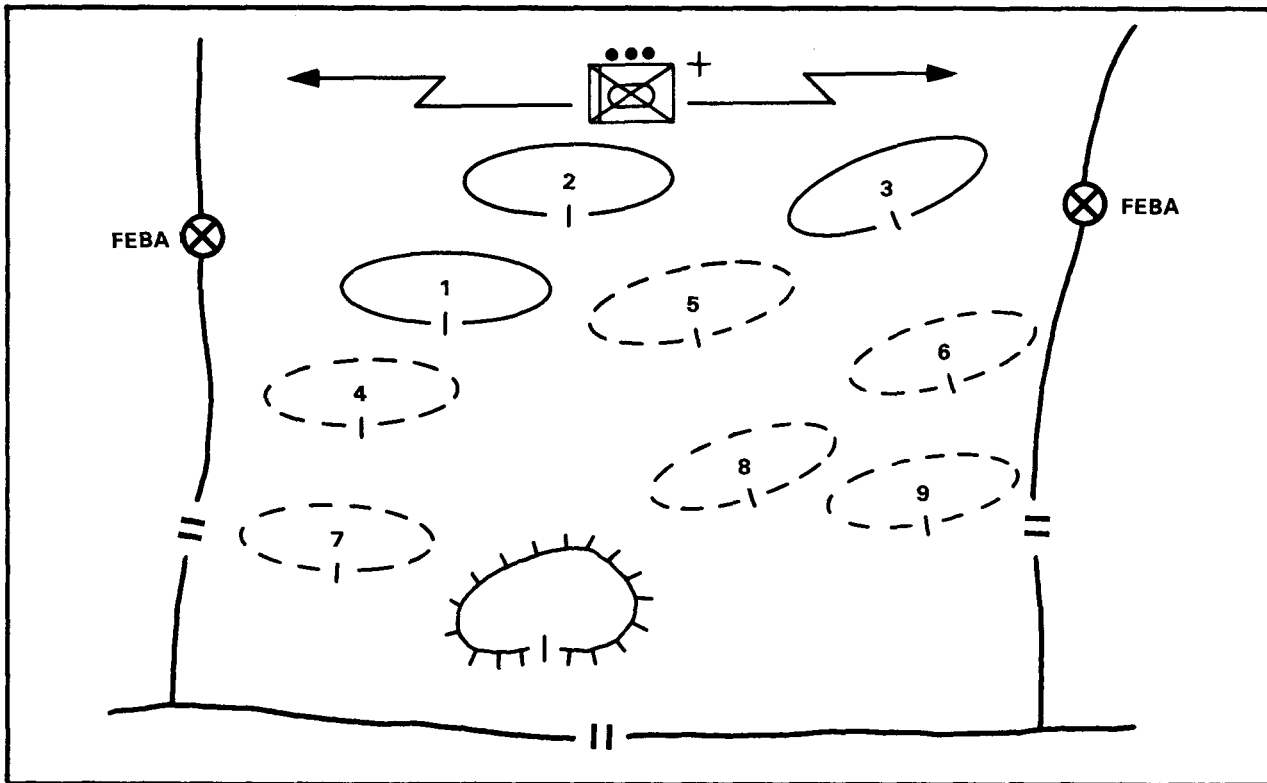

Figure 4-14. Battle positions and strongpoint.

- (3) In Figure 4-15, the task force commander has directed a forward defense using sectors and a strongpoint to the rear. He has positioned the mounted elements forward under his control and the dismounted elements in the strongpoint under

the control of the task force executive officer. The mounted elements will fight in depth within the sectors initially then from battle positions in support of the strongpoint.

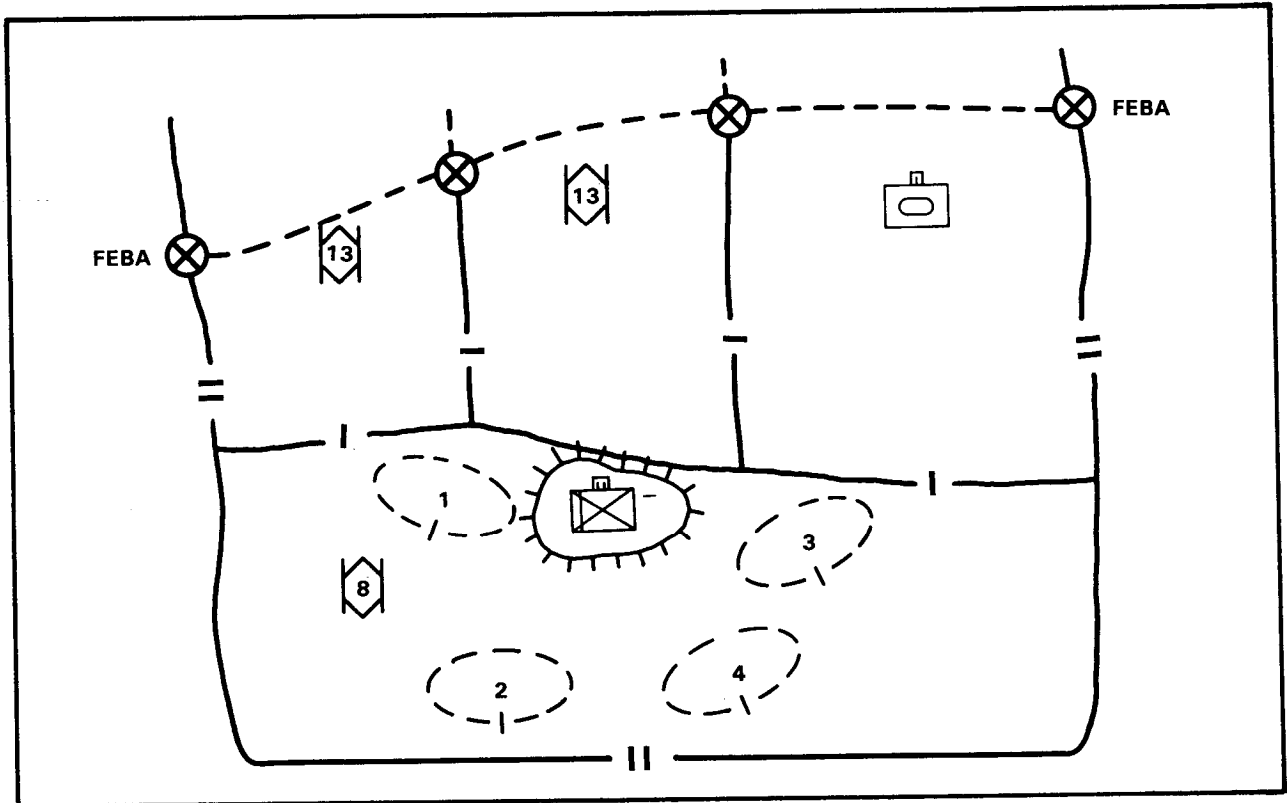

Figure 4-15. Fighting vehicle elements separated from the dismount elements in a strongpoint.

4-15. DEFENSE OF A BATTLE POSITION

- a. A battle position is a general location and orientation of forces on the ground, from which units defend. The BP can be for units from battalion task force to platoon size. A unit assigned a battle position is within the general area of the position (see Figure 4-16). Security forces may operate well forward and to the flanks of battle positions for early detection of the enemy and for all-round security. Units can maneuver in and outside of the battle position as necessary to adjust fires or to seize opportunities for offensive action in compliance with the commander's intent.

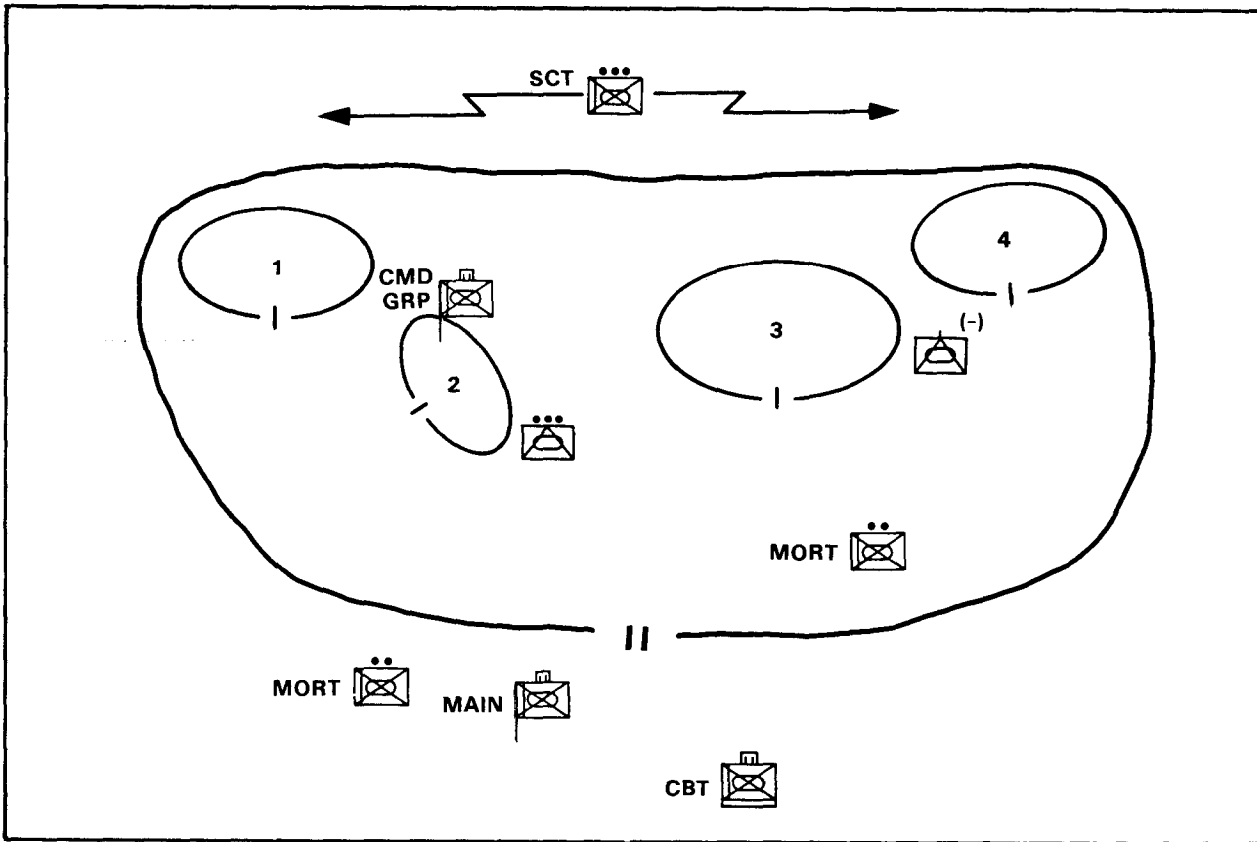

Figure 4-16. Disposition of forces in and around a battle position.

- b. The commander may maneuver his elements freely within the assigned BP. When the commander maneuvers his forces outside the BP, he notifies the next higher commander and coordinates with adjacent units. Task force security, CS, and CSS assets are frequently positioned outside the battle position with approval from the headquarters assigning the battle position.
- c. Based on the space available and the relative danger of nuclear and chemical attack, the commander will allocate space to subordinate elements within the general area of the battle position.
 - (1) In selecting a battle position for subordinate company teams, the task force commander thinks two levels down or in terms of platoon battle positions. He must provide sufficient space on each battle position to allow dispersed primary and alternate positions for antiarmor weapons. Room for limited

visibility, supplementary hide positions, and locations for combat trains are also considered.

- (2) The task force commander can vary the degree of maneuver of teams within the task force BP by allocating larger team BPs. BPs may also reflect positions in depth. They need not be a standard oblong shape that suggests a linear defense within the BP. Large positions are also used to increase dispersion in a nuclear and chemical environment.

4-16. DEFENSE OF A STRONGPOINT

- a. The mission to create and defend a strongpoint (see Figure 4-17) implies retention of terrain with the purpose of stopping or redirecting enemy formations. Battalion strongpoints can be established in isolation when tied to restrictive terrain on their flanks or on armor high speed avenues of approach tied to defensive positions of units on the flanks of the strongpoints. A bypassed strongpoint exposes the enemy's flanks to attacks from friendly forces in and outside the strongpoint.

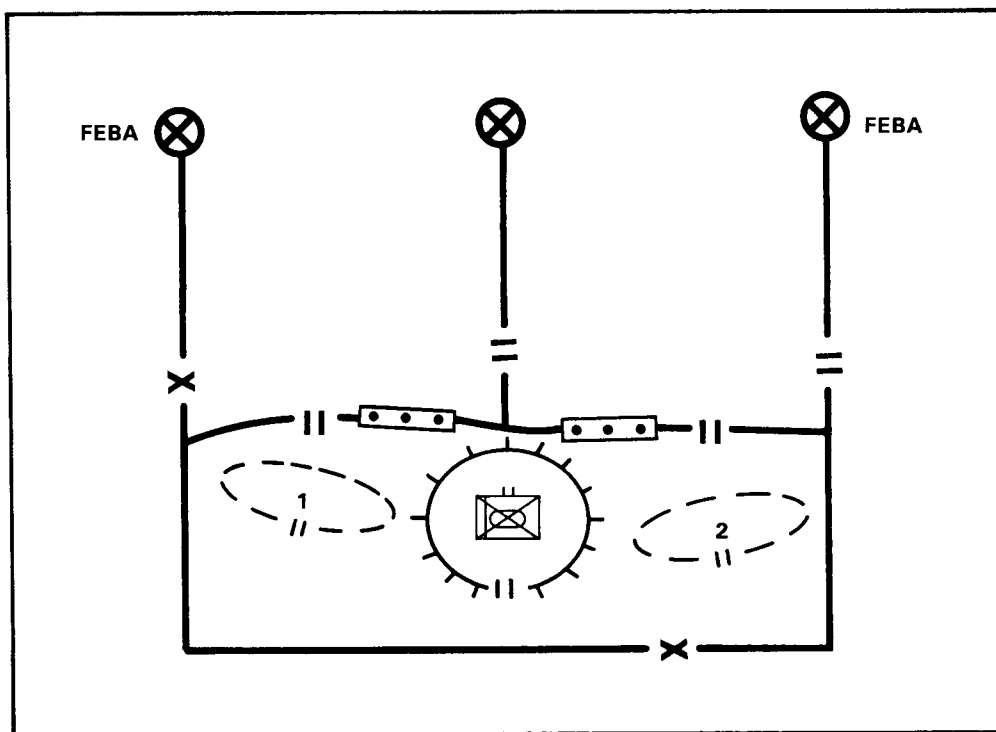

Figure 4-17. Battalion strongpoint.

- b. The task force pays a high cost in manpower, equipment, material, and time for the construction of a strongpoint. It takes several days of dedicated work to construct one. Strongpoints also sacrifice the inherent mobility advantage of heavy forces. Strongpoints may be on the FEBA, or in depth in the brigade MBA.
- c. When a strongpoint cannot be easily bypassed, repeated dismounted assaults must be expected and repelled. The strongpoint will receive intensive artillery attacks and must be prepared with overhead cover. Defense in depth is achieved through multiple positions within the strongpoint. The strongpoint defense is not normally conducted by a tank-heavy task force because of the limitations placed on a unit's ability to maneuver. Combat vehicles committed to the strongpoint defense use multiple firing positions, while dismounted infantry uses positions tied together with trenches.
- d. A task force assigned a strongpoint mission will be required to -
 - Plan movement to alternative positions within the strongpoint.
 - Coordinate with forces outside the strongpoint, including brigade counterattack forces.
 - Plan fires in detail.
 - Establish a small reserve to counter penetrations and, when appropriate, attack outside the strongpoint.
 - Receive priority of fire support and plan fires in detail.
- e. All positions within a strongpoint are mutually supporting (see Figure 4-18). Positioning must allow the massing of the fire of two or more units against an assault and prevent the enemy from isolating positions and defeating them in detail. Sectors of fire are designated to coordinate fires between positions. Avenues of approach into and around the strongpoint, which cannot be covered by forces in primary positions, must be kept under surveillance and covered by supplemental positions that are prepared in as much detail as time permits, and occupied on order.
- f. In the task force strongpoint defense, security forces operate forward initially or perform economy of force mission. On return to the strongpoint, scouts may screen to the rear. In Figure 4-19, the commander has separated dismounted and BFV elements, placing dismounted infantry in restrictive terrain while BFVs occupy positions in depth. Antiarmor occupies in-depth positions to cover sectors of fire and to gain standoff range. On-order alternate and supplementary battle positions are planned throughout the strongpoint. Mortars operate in split section

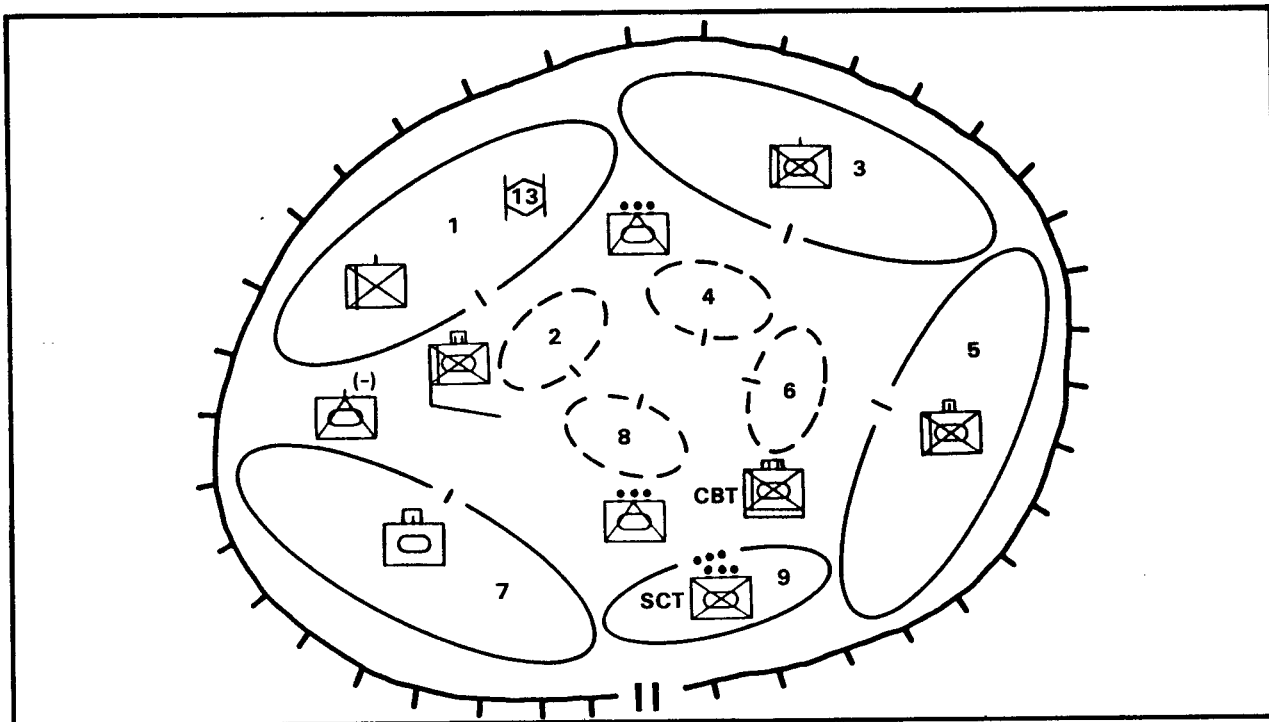

Figure 4-18. Battalion strongpoint with all forces within the strongpoint.

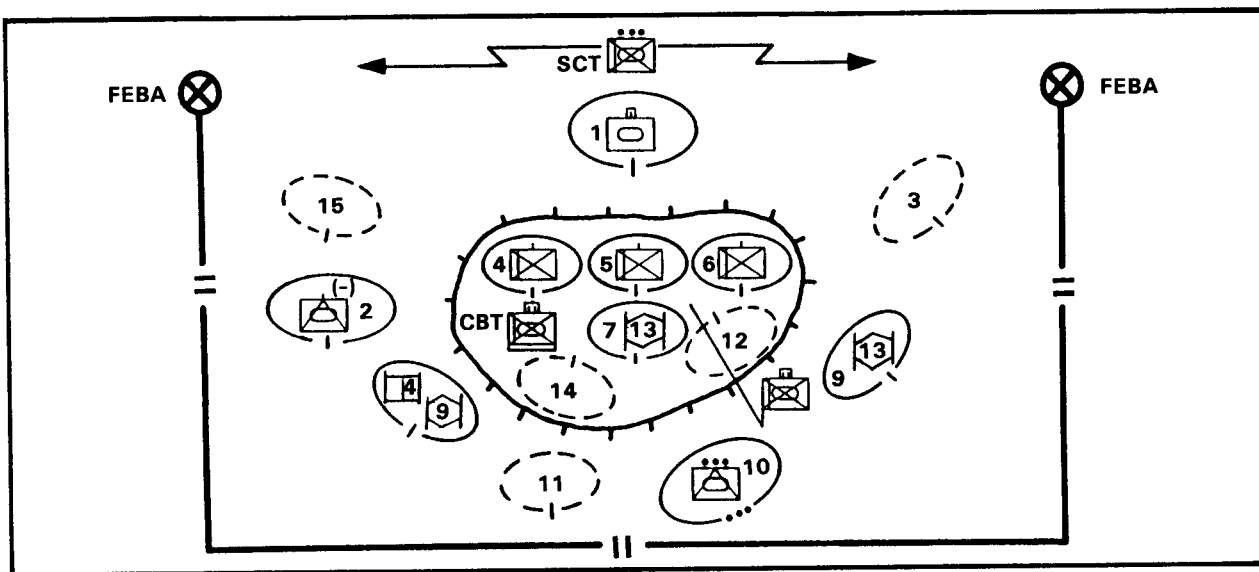

Figure 4-19. Task force strongpoint formed around a town and tied in with task forces on flanks.

masked by high ground or built-up areas in the center of the strongpoint. Combat trains, with emergency resupply of Class III and V, are in defilade positions or buildings within the strongpoint. Supplies are pre-positioned near primary, alternate, and supplementary positions. The brigade is required to provide units to keep the main supply route to the field trains open.

- g. In a task force defend in sector mission, the defense can be planned in depth around a strongpoint. The task force commander establishes a strongpoint formed around a small village, wooded area, or other obstacle in his sector using dismounted infantry and one company for a counterattack force. Remaining forces defend from BPs to the rear and flanks of the strongpoint and tie into the defenses of battalions on the flanks. Enemy forces moving down the avenue of approach are met with combined arms fires inside the strongpoint and long-range weapons to its flanks. Enemy forces are canalized into the engagement area formed around the strongpoint.

Section V. RESERVE OPERATIONS

When designated as a reserve for a higher headquarters, the task force may be assigned one or more of the following missions:

- Counterattack.
- Spoiling attack.
- block, fix, or contain enemy forces.
- Reinforce.
- Rear operations.

Given more than one mission, the task force commander develops, plans, coordinates, and prepares for execution of his contingencies based on the priority established by the higher commander.

4-17. COUNTERATTACK

- a. Counterattack planning and execution is assigned by brigade to committed and reserve task forces. Normally, more than one counterattack option is planned for and rehearsed. Counterattacks may be conducted to block an impending penetration of the FEBA, to stop a force that has penetrated, to attack through forward defenses to seize terrain, or to attack enemy forces from the flank and rear.

- b. Counterattacks may be conducted by fire only or by maneuver.
- c. Combat power is increased by the use of surprise, flanking attacks, speed, and violent execution.
- d. The counterattack must begin movement early and launch before the enemy has time to consolidate local gains. The commander must give on-order missions to his units so that they are prepared to quickly counterattack should the opportunity arise. Task forces other than the reserve may also be tasked to carry out local counterattacks. The offense fundamentals and techniques of the attack apply to all counterattacks.
- e. Regardless of the type of counterattack being conducted, the following basic considerations apply:
 - (1) Attack **one** objective at a time, and weight it with all available fire support. Once committed, the counterattack becomes the main effort.
 - (2) Plan the battle. Determine movement times and probable LD/LCs **before** committing the force to the counterattack.
 - (3) Defeat the attacker before being attacked by subsequent echelons.
 - (4) Attack the enemy's flanks and rear.
 - (5) Attack from an unexpected direction at an unexpected time taking advantage of protection offered by terrain and limited visibility.
- f. The brigade commander may designate on-order BPs from which the reserve task force can conduct counterattacks by fire. The reserve task force commander conducts a reconnaissance of those BPs and assigns his companies battle positions from which they can fire into engagement areas to stop enemy forces. Since those on-order BPs are close to forward deployed battalion BPs, or in their sectors, close coordination will be required for —
 - Routes from the reserve assembly area to the company BPs.
 - Fire coordination measures.
 - Tie-in of fires with forward units.
 - Supplementary positions for flank units.
 - Completion of the counterattack by maneuver if necessary.
 - Continuation of attacks beyond the FEBA.
 - Coordination of limit of advance.

- g. If an enemy force penetrates forward defenses, counterattacks by maneuver may be required to stop the enemy's attack. This type of counterattack may be conducted as a movement to contact and meeting engagement. Based on available information, the task force moves from its assembly area using an axis to the enemy's flank. Speed is essential. Movement is by traveling or traveling overwatch with companies in column until the enemy is located. Scouts move forward to make initial visual contact with the enemy. Once contact is gained, it is maintained until the counterattack begins. Scouts may then be repositioned to protect the flanks of the task force.
- h. A task force counterattack to destroy enemy forces forward of the FEBA begins with the movement of company teams from the reserve assembly area along separate routes to the attack position (see Figure 4-20). At the attack position, the task force may stop long enough to organize into the company formations to be used for the attack, pick up guides from the unit through which the counterattack force will pass, and be provided updated intelligence information. The task force moves through the forward defensive positions, and begins its attack as it crosses the LD (or LD/LC).
- i. The task force must coordinate direct and indirect fire control measures to protect itself against both enemy and friendly fire. Brigade may establish a restrictive fire area around the battalion's axis of advance and its objective. Fires must be planned along the axis of advance, on the objective, on the enemy force, and along the avenues of approach that could be used by enemy second-echelon units. The task force must maintain security to its flanks and rear. Recognition signals must be established by the brigade for close air support and for the task force's return to the MBA.

4-18. SPOILING ATTACK

This is a preemptive, limited objective attack aimed at preventing, disrupting, or delaying the enemy's ability to launch an attack. The objective of the spoiling attack is: the enemy force, not to secure terrain. The reserve is often used to conduct spoiling attacks so that forward units can concentrate on defensive preparations within the MBA. Spoiling attacks are normally directed against an enemy force that is preparing to conduct an attack, or that has temporarily halted to rearm, refuel, or make the transition from mounted to dismounted operations. Enemy artillery is also a prime target.

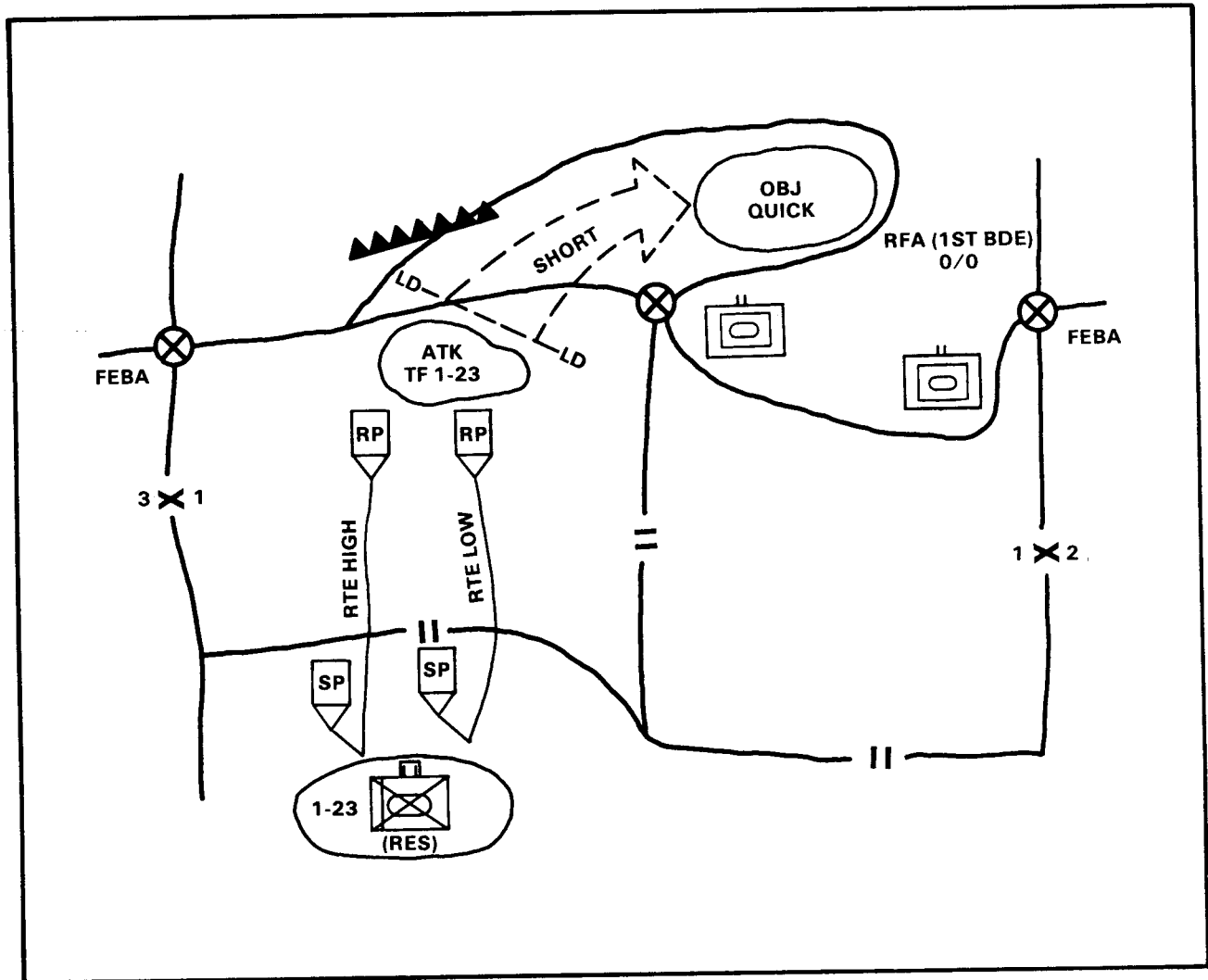

Figure 4-20. Counterattack by maneuver to destroy enemy forces.

4-19. BLOCK, FIX, OR CONTAIN

The reserve may be ordered to establish a hasty BP to block, fix, or contain enemy forces within a portion of the battlefield. This action may be necessary to blunt a penetration while other forces maneuver against the flanks or rear of the penetrating enemy force. An enemy force may be held in one area of the battlefield while he is defeated in another.

4-20. REINFORCE

Reserve forces may be committed to reinforce units that have sustained heavy losses or to build up stronger defenses in critical areas of the battlefield. Considerations must be given to how they will be integrated into the defensive scheme, command and control arrangements, and where they will be positioned. The techniques used to reinforce are similar to those used during a relief in place (see Chapter 5).

4-21. REAR OPERATIONS

The reserve battalion may operate as a division combined arms tactical combat force and be given a rear operations mission. The task force must not allow itself to become so dispersed that it cannot mass for other reserve missions. Nevertheless, the task force normally uses dispersed company positions, which both reduces the task force signature on the battlefield and helps spread its companies for the accomplishment of the rear operation. The task force completes intelligence preparation of the rear area for probable enemy avenues of approach and for likely landing zones and drop zones. It positions forces at the locations to interdict the rear area threat. Based on the IPB, location of CS and CSS elements within the brigade rear area, and their own dispositions, the task force assigns areas of responsibility to its companies or teams. Task forces are responsible for their own security within assigned areas. The task force also coordinates with CS and CSS base clusters for their defense, to include —

- Critical CS and CSS assets to be protected.
- IPB, to include local enemy approaches and possible LZs/DZs.
- Review of base and base cluster defensive preparations to include perimeter defensive sketches, OPs, patrols, obstacles, AD weapons sites, and reaction forces.
- Coordination of fire support.
- Coordination for aviation operations including reconnaissance, fire support, and transport.
- Coordination with military police and other combat-capable units and base cluster reaction forces.
- Events or contingencies that will trigger commitment of the task force to destroy a rear area threat.

Section VI. OTHER DEFENSIVE OPERATIONS AND TECHNIQUES

This section describes counterreconnaissance operations common to all types of defense. It also describes several defensive techniques that are METT-T specific.

4-22. COUNTERRECONNAISSANCE OPERATIONS

- a . Enemy reconnaissance operations will begin well ahead of any planned tactical operation. The task force must prevent the enemy from seeing its preparations. Enemy reconnaissance elements will conduct mounted and dismounted patrols to define positions, identify units, and detect friendly activities. His patrols will be small, move with stealth, and use concealment to observe friendly forces. These elements must be detected and denied information, or destroyed before they can report their observations. The task force's countersurveillance operations are integrated into the brigade plan to counter the enemy reconnaissance and surveillance efforts. In addition to patrols, this plan includes aerial surveillance, GSR, signals collection, indirect fires, and, if necessary, direct fires.
- b. Counterreconnaissance needs to be planned so as to use all assets available to detect the enemy reconnaissance elements early. The following tasks have to be performed to ensure that this gets done:
 - (1) Specify the security force mission. Screen, in addition to preventing direct observation by the enemy, implies long-range observation of enemy avenues of approach to provide early warning and detection, and neutralization or destruction of enemy reconnaissance elements. The method and means to accomplish this should be specified.
 - (2) Provide sufficient assets. At least a screening force is needed to detect the enemy's approach and defeat the enemy's reconnaissance efforts. A forward security force can be established to provide greater resistance and deception, if the terrain allows.
 - (3) Establish security early and well forward. In coordination with covering force operations, the task force security element should be in place before the company teams move into their battle positions and before work on obstacles begins. The security force must be far enough forward to prevent enemy observation of defensive preparations.

- (4) Put security in the right place; ensure complete coverage. Based on terrain and threat analysis, the S2 templates likely enemy reconnaissance objectives and routes and recommends the general location of the security force to the S3; the commander approves the plan. The security force commander adjusts the plan to the ground situation and specifies exact locations for each OP. This ensures long-range observation and complete, overlapping coverage of the task force sector; adjustments are reported to the TOC. During good visibility, OPs are normally established along high ground with patrolling, as necessary, between OPs. During limited visibility, positions can be adjusted to ensure covering the areas between positions. More OPs placed closer together with almost continuous patrolling between them are required. Day positions are reoccupied before BMNT. It is important to tie in with the security forces of adjacent task forces. The battalion should coordinate contact points with leaders meeting on the ground.
- c. The S2 supervises the planning and establishes reporting procedures. As reconnaissance elements are detected, their activity and equipment must be reported. The S2 will use the information in developing his picture of the enemy.
 - d. The countering of enemy ground reconnaissance activities is a crucial task in the defense and is accomplished primarily through active measures. Considerations for integrating counterreconnaissance assets into the task force plan are as follows:
 - (1) **Scouts.** The primary counterreconnaissance asset of the task force. Most often used to provide a framework for the integration of other assets.
 - (2) **GSR.** Usually limited to open terrain and best used to cover open, high-speed avenues of approach where early detection is critical. GSR can also be used to monitor defiles, detect enemy reconnaissance elements, vector patrols, and assist in withdrawals. The effectiveness of GSR is improved by using overlapping sectors, the “flicker” on-off technique to avoid detection, and a well-enforced sleep plan to ensure that GSR operators are alert. GSR positions should be reconnoitered during daylight and occupied just before dark. Targets can be generally identified at 10 kilometers or less, movement can be detected at much greater ranges. Therefore, GSR can also be used in good visibility to support the long-range visual effort of the scouts. Because of their long range, GSRS can often support the security mission without being placed on the screen line. GSR NCOs are technical experts on the

capabilities of their systems and should be included in the planning process.

- (3) **TOW/ITV.** These elements can be used to occupy OPs and destroy enemy reconnaissance vehicles. TOW\ITV squads should be used to cover open terrain to take advantage of their long-range capability. However, the thermal sights of the ITV cannot be used continuously because of battery limitations. The crew is also smaller and less familiar with security operations than a scout squad. The use of TOW/ITV squads detracts from their ability to prepare for the defense.
- (4) **Maneuver units (tanks and infantry).** Manning OPs and patrolling are normal infantry missions. Consideration for using infantry squads must be tempered by the MBA preparation time these squads need. Each tank crew can man only one OP, and the OP should be used to cover a relatively open, high-speed avenue of approach. Tanks and rifle squads used in the security force will not be immediately available in the MBA. TF directed emplacement and monitoring of platoon early warning systems can supplement REMS, OPs, and patrols.
- (5) **Provide adequate command and control for security forces.** All elements of the security force must be under one leader. Normally this is the scout platoon leader. If extensive reinforcement is needed, or if a greater degree of resistance is required, the mission can be given to a maneuver company commander.
- (6) **Plan to recover of forward security elements.** Too often units underestimate the speed of an enemy attack and begin their withdrawal too late. Specific guidance on both engaging the enemy and moving is required for the security force commander. Units receiving effective enemy fires cannot reasonably be expected to move unless those fires are suppressed or obscured. Issue precise instructions that will preclude decisive engagement and plan to provide illumination, suppression, and or obscuration. Movements should be made over previously reconnoitered routes, when supporting fires are required. For withdrawal to the MBA, routes should go around friendly units if possible, rather than through them to avoid masking friendly overmatching fires. Routes, passage points, recognition signals, and timing must be coordinated between forward security elements and company teams in the MBA. Withdrawal must be planned for both day and night. If practical, full-scale rehearsals should be

conducted to ensure that timing and coordination are sufficient. This is particularly important in withdrawing a sizeable security force or withdrawal over significant obstacles.

- (7) **Plan for subsequent reconnaissance operations.** Company teams often become so involved in fighting that they do not report the information needed for the task force commander to “see the battlefield.” It is often useful to have security forces remain forward and continue to observe and direct fires against enemy maneuver, overwatch, and second echelon elements. This can sometimes be accomplished by displacing elements of the security force laterally rather than pulling them back to the MBA. Another subsequent mission is to screen a vacated sector when a company team is repositioned. GSRs can be used to determine accurate ranges for indirect fires and to monitor enemy smoke to see if it actually masks vehicles or is a deception. A common secondary mission for security forces is a flank screen. In determining which flank should be screened, the primary consideration must be that flank which has the most dangerous enemy avenues of approach. If neither flank presents a special danger, the flank boundary of an allied unit or a higher level DS unit should be considered.
- (8) **Establish local security.** Enemy reconnaissance elements and patrols will attempt to slip past forward security forces. Therefore, maneuver elements, CPs, and CS and CSS positions must establish their own local security. OPs and ambush patrols should cover obstacles, gaps between battle positions, and avenues of approach. Supporting fires should be planned around and between battle positions and on obstacles. Available night vision devices should be positioned to ensure all-round visibility. Dead space must be covered. These efforts should be coordinated through the S2 to ensure full coverage and avoid friendly force engagements. Subordinate maneuver elements should be specifically tasked to cover the areas between battle positions and to provide reaction forces as required. The S2 consolidates the reconnaissance and surveillance plan with brigade.

4-23. STAY-BEHIND/HIDE FORCES

- a. The purpose of a stay-behind force is to surprise, counterattack, defeat, and confuse the enemy. The stay-behind or hide force counterattacks enemy combat forces from the rear, or attacks and or ambushes his command and control, combat support, and

combat service support elements (see Figure 4-21). This mission is a high risk operation and should not be considered lightly.

- b. The commander may accept risk to take advantage of terrain to hide a force in a perimeter defense until forward enemy elements

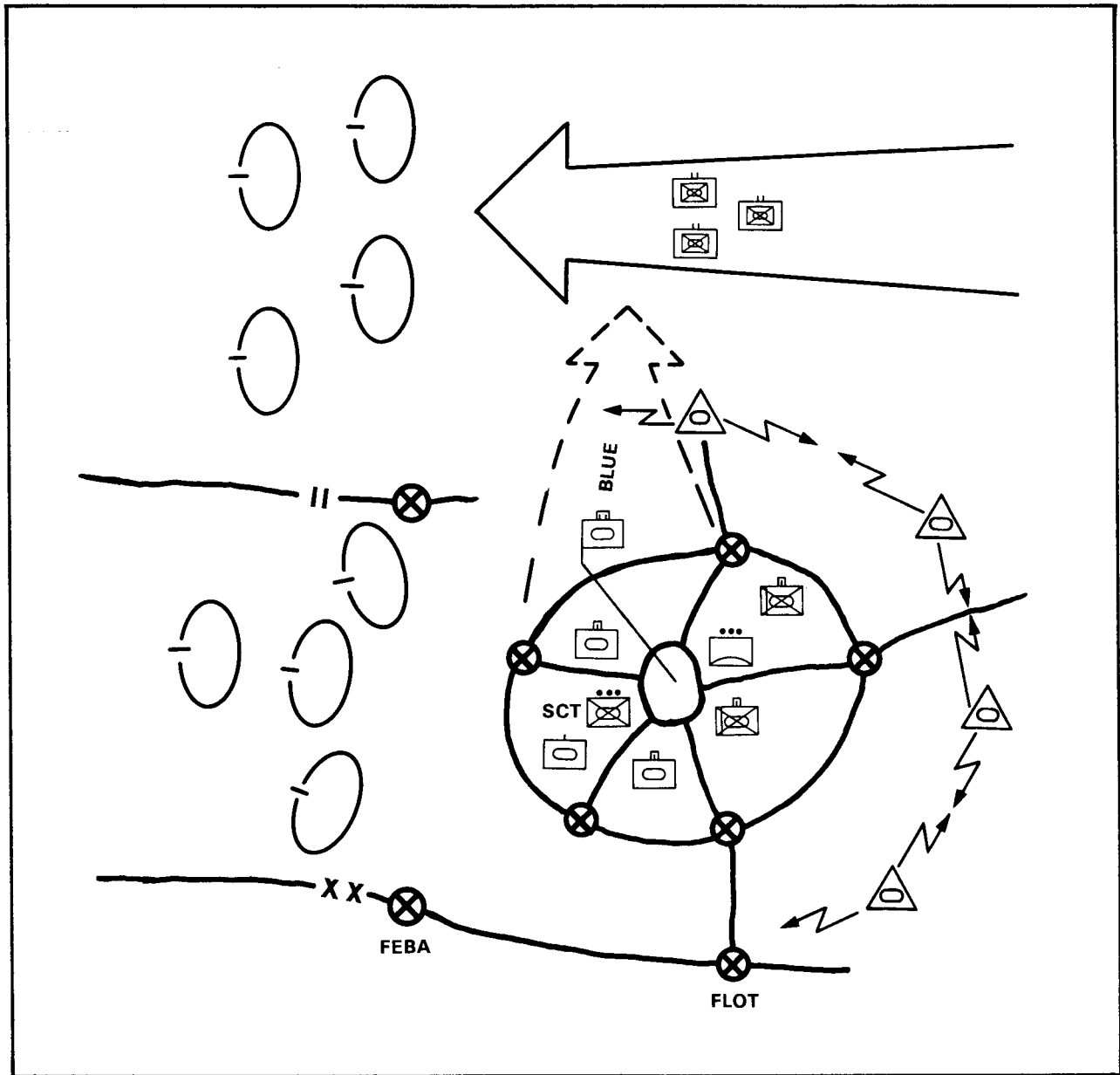

Figure 4-21. Stay-behind force attacking second-echelon battalion.

have passed the unit. Similarly, units inadvertently bypassed by the enemy may capitalize on the position to use it as a tool for offensive action in the enemy rear.

c. Success of the stay-behind force is based on —

- The enemy's desire to achieve rapid rates of advance with his first echelon.
- The brigade or division's ability to create a break between the attacking echelons.
- Maintaining the integrity of the force and gaining surprise by remaining undetected.

d. The stay-behind force operation is a four-phase operation:

- Initial defense as part of MBA battle.
- Perimeter defense and avoiding detection.
- Breakout and attack.
- Linkup with parent unit.

e. Planning considerations for a stay-behind force include —

- (1) A stay-behind force positioned in the MBA may participate in some fighting.
- (2) A stay-behind force positioned forward of the MBA avoids detection and does not participate in the initial fight.
- (3) FA should be positioned to fire in support of the force and restrictive fire control measures planned.
- (4) CS and CSS assets accompanying a stay-behind force are normally only the task force mortars, combat trains, and company and or combat trains. Use of wheeled vehicles should be limited in a stay-behind force.
- (5) The return routes for the stay-behind force must be the best covered and concealed routes available. Obstacles along these routes should have guarded lanes or gaps or should be scheduled for self-destruction before the stay-behind force must cross them.
- (6) Rally points should be designated.
- (7) The stay-behind force should plan for a breakout and linkup with its parent unit following accomplishment of its mission.
- (8) Camouflage, cover, concealment, and SIGSEC must be planned in detail.

Example

In the example shown in Figure 4-22, a mechanized-infantry-heavy battalion task force hides in a covered and concealed position forward of the FEBA. This task force is in position to outflank an enemy avenue of approach or attack a likely location for enemy command and control, air defense, or trains elements, and can defend BP 8. In the brigade plan, after passage of the covering force, the stay-behind/hide force is to counterattack to Objective RED. The commander's intent is to destroy enemy command and control, air defense, and supply vehicles. Upon completion of the counterattack or on order, the task force delays to Route BILL, returns through passage point 1, and occupies assembly area JIM to reconstitute, refit, rearm, refuel, and rest. The task force maintains radio-listening silence as it crosses the FEBA. It must be in position before battle handover at PL HARRY and should not begin the attack until the covering force has passed and the enemy can be surprised.

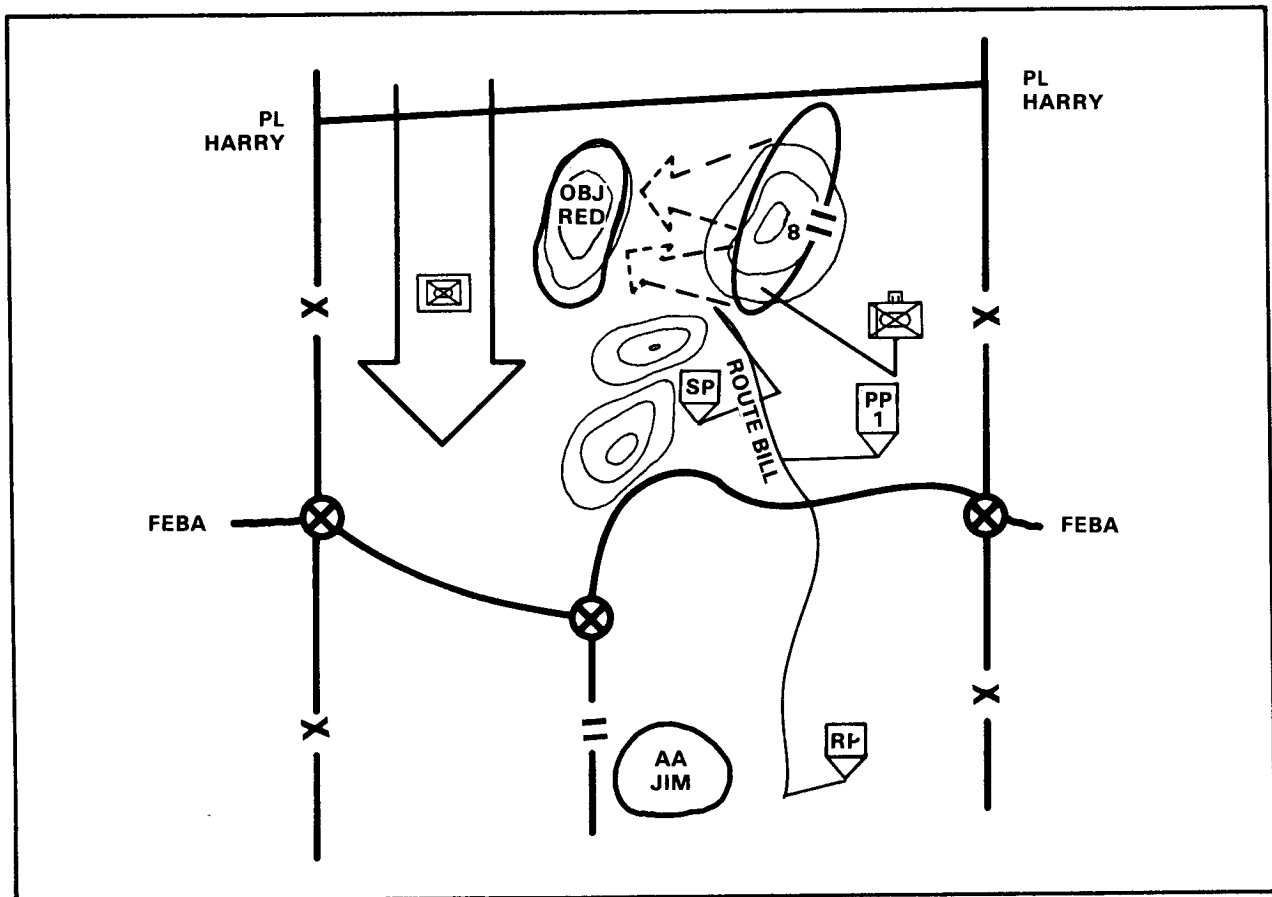

Figure 4-22. Stay-behind force attack and withdrawal plan.

A premature attack would result in the destruction of the force. The task force commander conducts an estimate of the situation and develops the following plan:

Each team initially occupies camouflaged defensive positions. Company teams run wire into the battalion task force TOC to maintain radiolistening silence. Scouts screen the flank of the task force BP, report covering force passage and enemy approach. The covering force performs its defense or delay mission, passes lines, withdraws, and hands over the battle at PL HARRY. Task force scouts maintain the screen. The scouts report locations, types, and quantities of enemy command and control elements, ADA, and engineer vehicles.

On order, teams conduct a movement to contact, bypassing friendly obstacles if possible, and occupy BP5, BP6, and BP7 (Figure 4-23). Upon occupation, teams engage enemy forces in their respective engagement

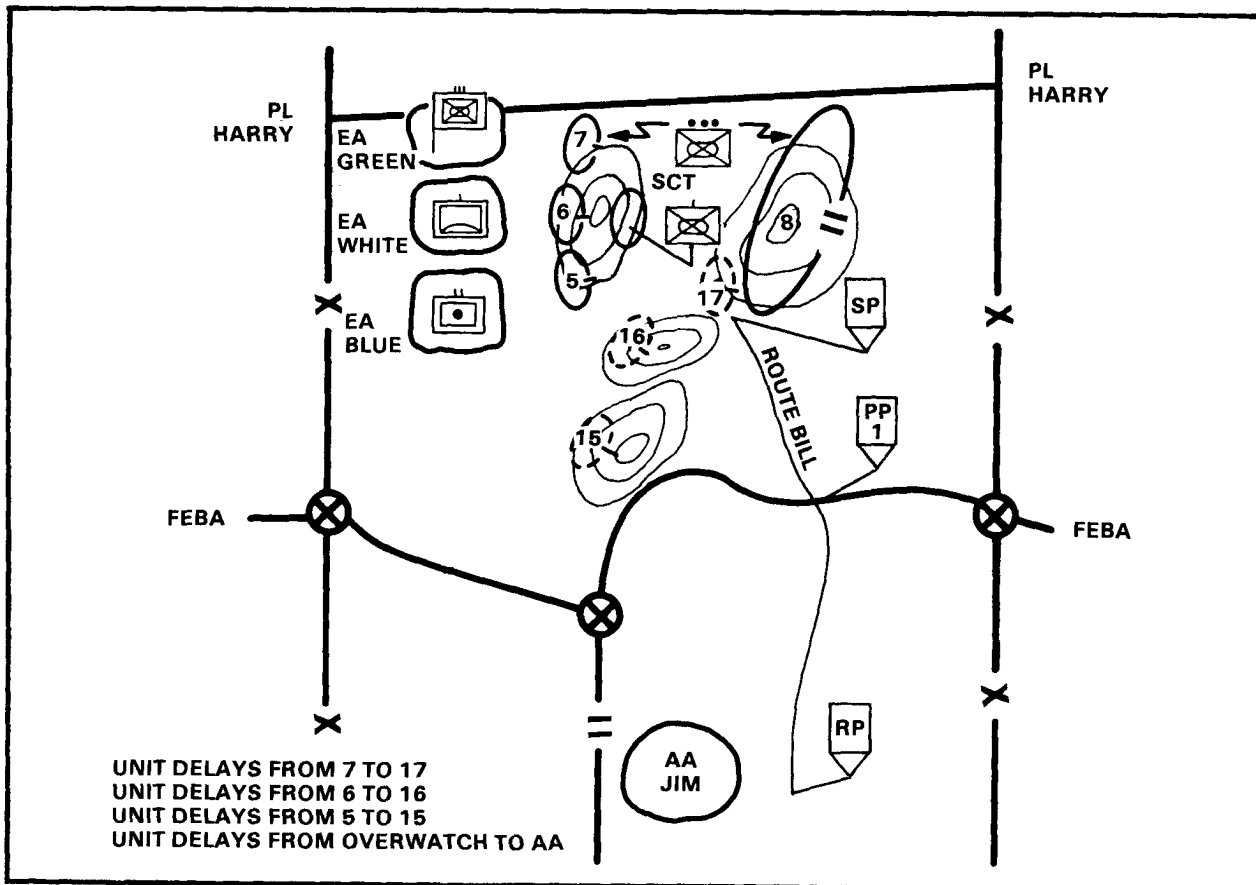

Figure 4-23. Stay-behind force company objectives and delay positions.

areas (GREEN, WHITE, and BLUE). Mortars and artillery fire into the engagement areas and also fire screening smoke to confuse follow-on echelons.

The task force commander maintains these positions as long as possible. On order, the teams disengage and, if pursued, delay to the march start point using battle positions 17, 16, and 15.

4-24. PERIMETER DEFENSE

- a. A perimeter defense is oriented in all directions (see Figure 4-24). A task force organizes a perimeter defense to provide self-protection. A perimeter is established when the task force must hold critical terrain in areas where the defense is not tied in with adjacent units. The task force may also form a perimeter when it has been bypassed and isolated by the enemy and must defend in place. The general form of a perimeter is also used when the task force must prepare and defend from a strongpoint.

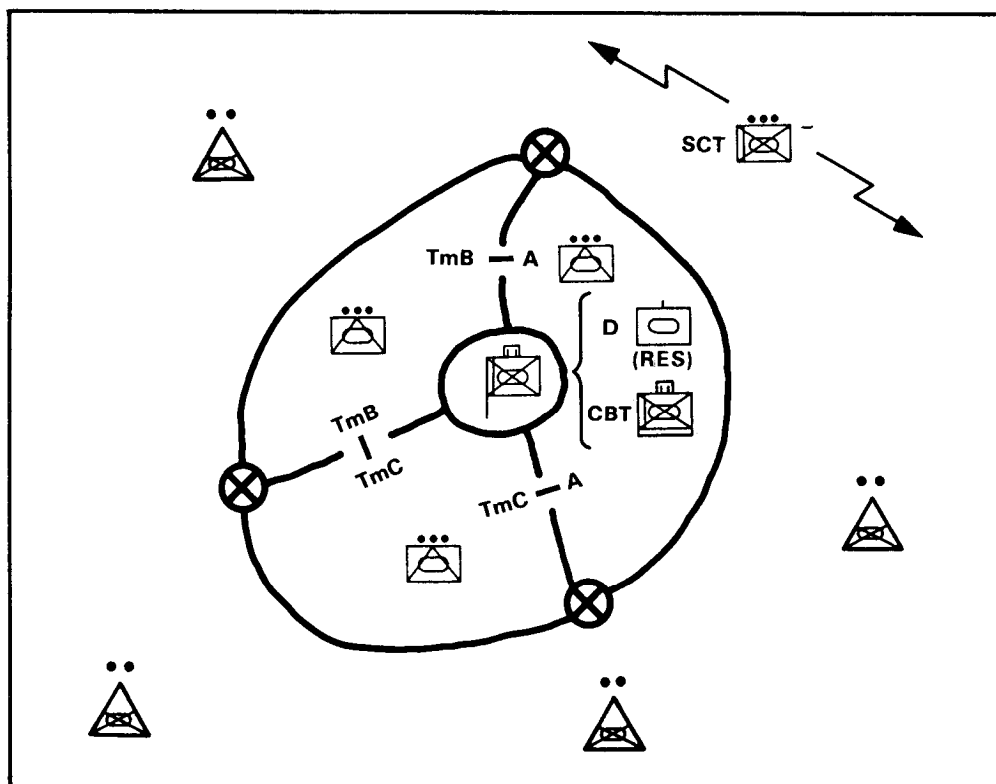

Figure 4-24. Perimeter defense.

- b. Any requirement to hold or protect features, such as bridges, airfields, or landing zones, from enemy observation and fire restricts the flexibility of units while in a perimeter. These restrictions and the inability to achieve depth make a perimeter defense particularly vulnerable to armor. The commander minimizes these vulnerabilities by—
 - Placing security as far out as possible.
 - Positioning antiarmor weapons systems on armor-restrictive terrain, concentrating their fires on armor approaches.
 - Constituting an armor-heavy reserve.
- c. Although time for planning varies, the sequence of establishing a perimeter is generally the same as for other defenses. A tentative perimeter line should be selected to take advantage of defensible terrain. An effort should be made to retain terrain that is key to future linkup, extraction, or breakout.
- d. The perimeter line takes advantage of terrain and obstacles while ensuring that the defense will not be too thin or the perimeter too small. A battalion task force normally establishes a perimeter 2 to 4 kilometers in diameter.
- e. The perimeter is divided into company sectors with boundaries and coordinating points.
- f. The task force commander normally employs the security elements outside the perimeter for early warning. He may augment security with mounted or dismounted patrols and OPs provided and controlled by units on the perimeter. The security elements are positioned to observe avenues of approach. Areas that cannot be observed by stationary elements are covered by patrols and early warning devices. If the security element remains under the control of the task force commander, it must coordinate with units on the perimeter before passage into the perimeter.
- g. The reserve defends a portion of the second line of defense behind the perimeter elements. The reserve must have the mobility necessary to react to enemy action in any portion of the perimeter. It is positioned to block the most dangerous avenue of approach and is assigned on-order positions on other avenues that may be critical.
- h. If the perimeter is penetrated, the reserve blocks the penetration or counterattacks to restore the perimeter. After committing the reserve, the commander must reconstitute a reserve to meet other threats. This force normally comes from an unengaged unit in another portion of the perimeter. If an unengaged force is used to constitute a new reserve, sufficient forces must be retained

in the vacated sector to defend that portion of the perimeter. The ability to separate BFV and dismounted element allows the commander to designate a mobile reserve in each company sector.

- i. The employment of organic and attached weapons in a perimeter defense is the same as for other defense operations. Indirect fire weapons engage the enemy as far forward of the perimeter as possible. Field artillery may support the task force from within the perimeter or from another location. If within the perimeter, plans should include the use of artillery in both a direct and an indirect fire role.
- j. If the task force forms the perimeter because of isolation, combat, combat support, and combat service support elements from other units come under the tactical command of the senior commander in the perimeter. They are given missions based on their support capabilities. All service support assets within the perimeter should be in a protected location from which they can provide continuous support. Their location and operation should not restrict or be restricted by the fires or movement of perimeter fire support and reserve units.
- k. Resupply may have to be by air. The availability of landing and drop zones is an important consideration in selecting and organizing the position.

4-25. REVERSE SLOPE DEFENSE

- a. The reverse slope defense uses the topographical crest to mask the defender from the supporting direct fire and observation of the attacker.
- b. A task force rarely conducts a reverse slope defense along its entire front; however, there may be situations where subordinate units and weapons systems may be employed on the reverse slope. The task force commander may adopt a reverse slope position for elements of the battalion:
 - When the forward slope is made untenable by enemy fire.
 - When the forward slope has been lost or not yet gained.
 - When the terrain on the reverse slope affords better or equal fields of fire than on the forward slope.
 - When the possession of the forward slope is not essential for observation.
 - To avoid creating a dangerous salient in friendly lines.

- To surprise the enemy and to deceive him as to the location of the battalion main defensive positions.
 - When seeking to gain protection from the effects of nuclear or chemical fires that are anticipated forward of the friendly position.
 - To deny the enemy direct observation and fires onto the defensive position and facilitate resupply.
 - When time to prepare positions is limited.
- c. A reverse slope position is particularly effective when flanking fires from units on adjacent terrain features can be placed on the forward slope. However, the key to the reverse slope defense is control of the crest by fire and the proper use of obstacles, as in Figure 4-25. The result is surprise, isolation, and defeat of a manageable portion of the attacker's force.

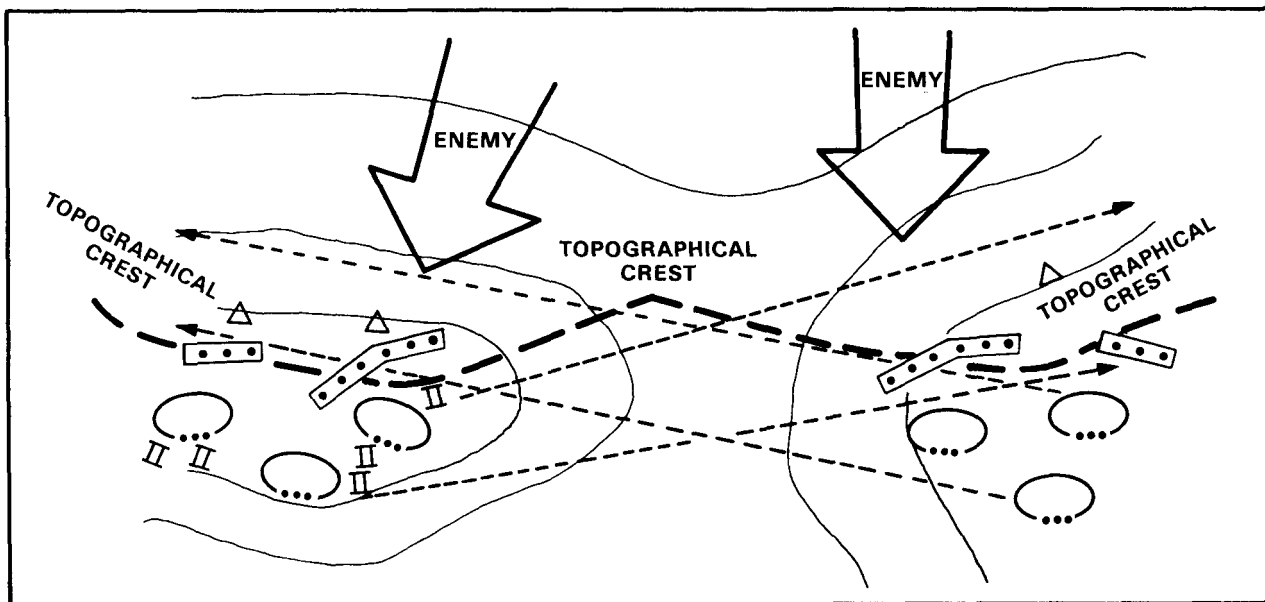

Figure 4-25. Creating local superiority through surprise from reverse slope positions.

- d. The reverse slope defense can be especially effective against fast-moving mechanized forces. It establishes an engagement area for the concentration of heavy firepower into which the enemy moves directly after reaching the crest of a hill or ridgeline. The result is a surprised enemy who is engaged by weapons that are in defilade to all but his forward element, which is under heavy fire.

- e. The defender uses a reverse slope to isolate the lead echelon from follow-on forces. This eliminates the direct fire from weapons in the follow-on echelon. The attacker's effective use of combined arms is disrupted, and his tanks may be unable to depress their gun tubes far enough to provide effective fires. This gives the defender opportunities for "belly shots" at enemy armor.
- f. The reverse slope defense is organized according to the fundamentals that apply to all defensive positions. A reverse slope position requires good fields of fire to the crest of the hill and, if possible, to the forward slope of adjacent reverse slope positions. Fires should be placed on the crest and the reverse slope. Another factor affecting the organization of the reverse slope position is adjacent reverse slope defensive positions.
- g. If the situation permits, a security element should be established on the forward slope to stop or delay the enemy, disorganize his attack, and deceive him as to the location of the defensive position. The security element should be strong enough to strip away enemy reconnaissance, begin long-range engagements, and force the enemy to deploy and assault the forward slope.
- h. Observation posts must be established just forward of the topographical crest to give long-range observation over the entire front. The OPs should include forward observers from the FIST. The number and composition of the OPs should be strengthened at night.
- i. Reserve or overmatching elements may be on the military crest of the next high ground to the rear if it is within supporting range.
- j. Observation and fires are maintained over the forward slope as long as possible to disrupt the enemy and prevent him from massing for the assault. Disengagement time is determined by the distance the security force elements must travel to their subsequent positions.
- k. Direct fire weapons on the reverse slope and next high ground to the rear withhold their fires until suitable targets appear. As the enemy crosses the crest, priority targets are initiated. Artillery and mortar fires and smoke against the topographical crest assist in the isolation of the attacker.
- l. If the enemy is successful in seizing the crest, or if he makes a penetration, a counterattack may be launched to destroy him and to restore the crest.

- m. Finally, the commander's estimate may lead him to organize reverse slope positioning only for selected weapons. (Figures 4-26 and 4-27 illustrate reverse slope positioning.)

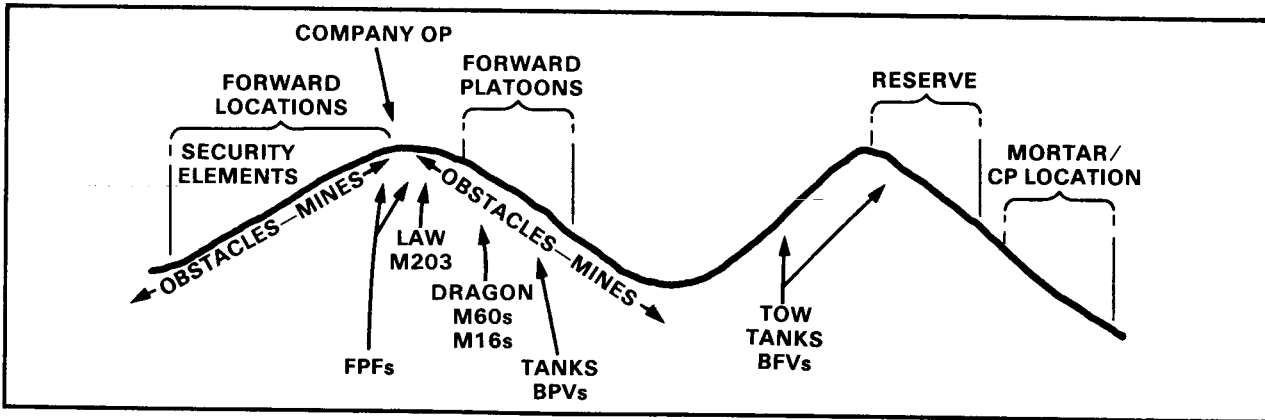

Figure 4-26. Reverse slope weapons' positions.

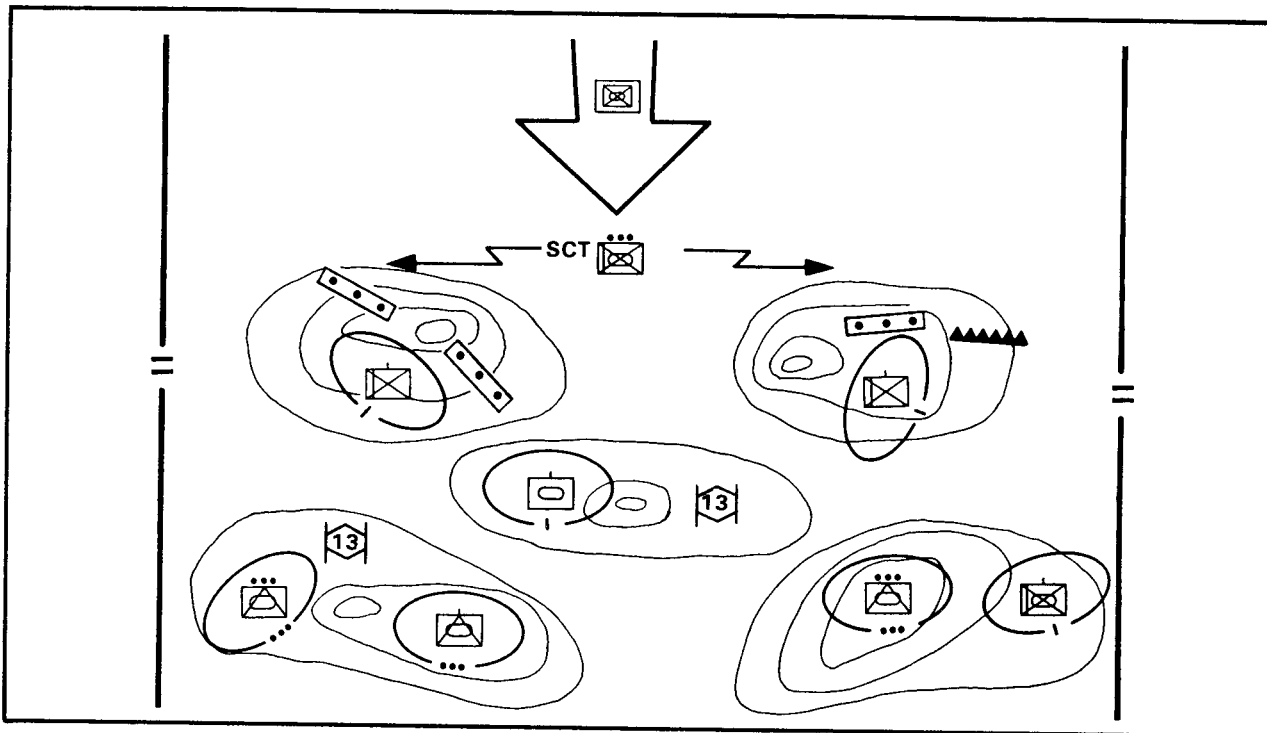

Figure 4-27. Detailed combined arms integration of reverse slope/forward slope.

4-26. URBAN AREA OPERATIONS

- a. On the battlefield, the defender uses the advantage of both natural and man-made features. Urban sprawl adds strength to the defense by providing covered and concealed positions and by restricting the attacker's mobility and observation. A task force normally defends 4 to 12 city blocks, depending on the type of urban area.
- b. Dismounted infantry occupies battle positions or strongpoints around which the mobile battle is fought. In restrictive urban terrain, dismounted forces may be required to find the enemy, deny him the ability to attack without being detected, and then fight the close-in battle. If a built-up area must be retained, a position defense is organized in depth and supported by strong mobile forces.
- c. The urban area defense begins with mobile, combined arms forces deployed well forward of the urban area. Company teams in BPs or sectors are organized in-depth to control approaches to the urban area. Small villages and strip areas are incorporated into the defensive scheme in the same manner as other terrain features. Tanks and BFVs can operate in and around these built-up areas, concentrating their fires into engagement areas between the villages. Tanks and BFVs maneuver outside and between these areas to contribute their fires from different directions and cause the enemy to fight a nonlinear battle. The defense is anchored with dismounted infantry in BPs and strongpoints in the villages. (See Figure 4-28, page 4-62.)
- d. The handover of the battle by the forward force must not allow the enemy to gain momentum. The restrictive nature of the urban terrain complex, obstacles, and readily available defensive positions may facilitate the handover if properly coordinated.
- e. Restrictive or compartmented areas within urban terrain may provide the enemy with covered or concealed infiltration routes into the defensive position. Responsibility for all blocks, rooftops, and underground rail and sewer systems must be clearly defined.
- f. Urban areas usually sit astride or dominate high-speed avenues of approach through or around the urban area. If urban areas cannot be bypassed easily, they may reduce the momentum of the enemy's attack. (For a detailed discussion on defensive operations in urbanized terrain, see FM 90-10.)

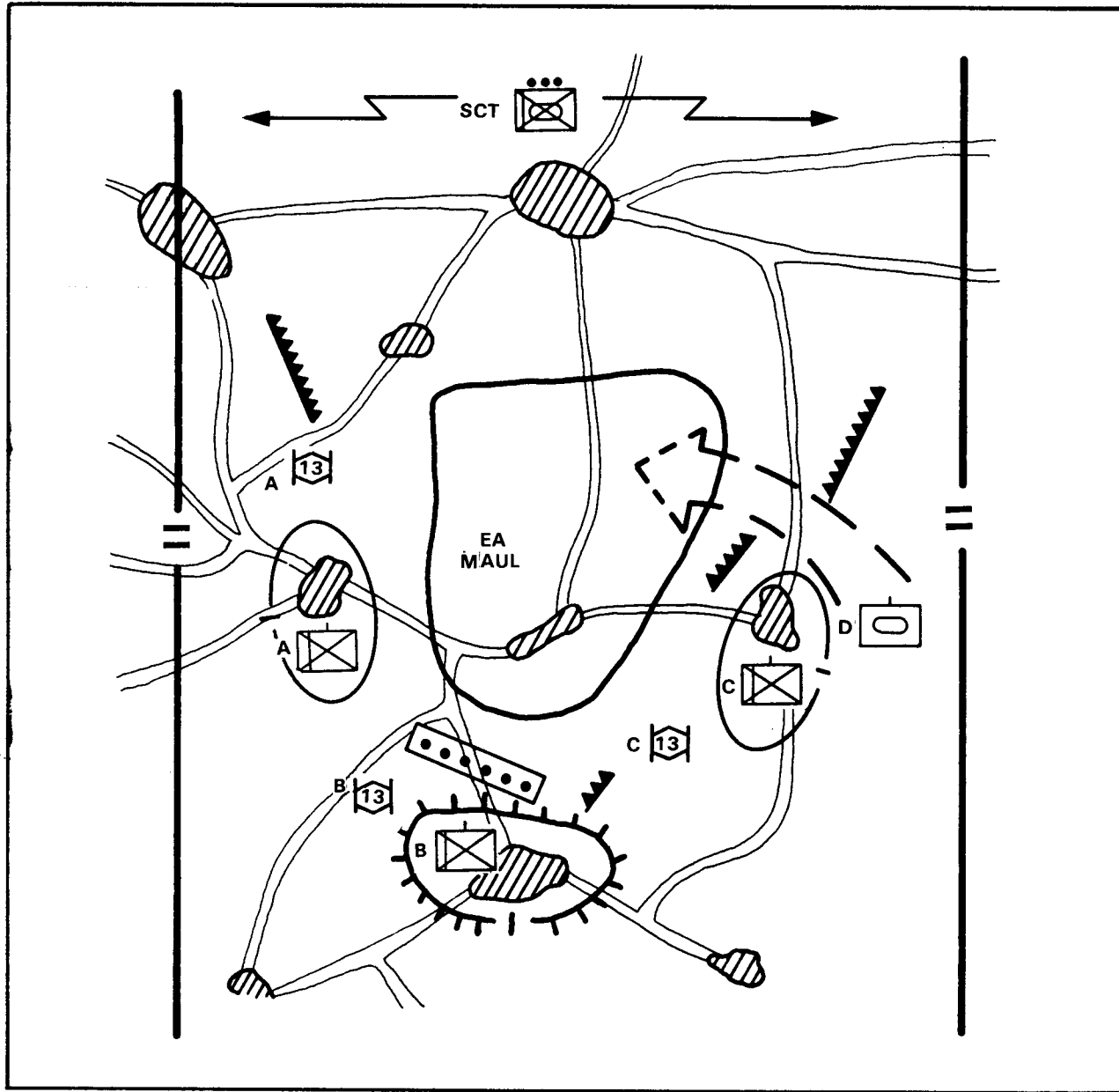

Figure 4-28. Task force sector defense incorporating built-up areas.

CHAPTER 5

OTHER TACTICAL OPERATIONS

This chapter discusses operations requiring special considerations. The fluid and rapidly changing environment of the AirLand battlefield will require units to conduct these operations more frequently and rapidly than in the past.

CONTENTS		
PARAGRAPH		PAGE
Section I.	RETROGRADE OPERATIONS	5-2
5-1	Types and Planning Considerations	5-2
5-2	Delay	5-4
5-3	Withdrawal	5-13
5-4	Retirement	5-20
Section II.	PASSAGE OF LINES	5-20
5-5	Purpose	5-20
5-6	Planning Considerations	5-21
5-7	Rearward Passage	5-23
5-8	Forward Passage	5-26
Section III.	RELIEF OPERATIONS	5-28
5-9	Purpose	5-28
5-10	Types	5-28
5-11	Conduct of the Relief	5-29
Section IV.	BREAKOUT FROM ENCIRCLEMENT	5-33
5-12	Purpose	5-33
5-13	Planning Considerations	5-34
5-14	Conduct of the Breakout	5-37
Section V.	LINKUP	5-39
5-15	Purpose	5-39
5-16	Planning Considerations	5-39
5-17	Conduct of the Linkup	5-40
Section VI.	HASTY WATER CROSSINGS	5-43
5-18	Purpose	5-44
5-19	Characteristics	5-44
5-20	Planning Considerations	5-44
5-21	Conduct of Hasty Water Crossings	5-47
Section VII.	GUARD OPERATIONS	5-51
5-22	Purpose	5-51
5-23	Types of Guard Operations	5-51
5-24	Conduct of Guard Operations	5-52

PARAGRAPH	PAGE
Section VIII. OBSTACLE REDUCTION	5-60
5-25 Bypassing Obstacles	5-60
5-26 Breaching Obstacles	5-60

Section I. RETROGRADE OPERATIONS

Retrograde operations are organized movements away from the enemy. A retrograde may be forced by enemy action or executed voluntarily. The underlying reason for conducting a retrograde operation is to improve a tactical situation or prevent a worse one from occurring. A retrograde operation may be used to economize forces, maintain freedom of maneuver, or avoid decisive combat. A battalion task force conducts a retrograde as part of a larger force to —

- Avoid combat under unfavorable conditions.
- Gain time.
- Reposition or preserve forces.
- Use a force elsewhere.
- Harass, exhaust, resist, and delay the enemy.
- Draw the enemy into an unfavorable position.
- Shorten lines of communication and supply.
- Clear zones for friendly use of chemical or nuclear weapons.
- Conform to the movement of other friendly forces.

5-1. TYPES AND PLANNING CONSIDERATIONS

a. **Types.** There are three types of retrograde operations: delay, withdrawal, and retirement. They can be characterized as follows:

Delay — Trade space for time and avoid decisive engagement to preserve the force.

Withdrawal — Break contact. (Free a unit for a new mission.)

Retirement — Move a force not in contact to the rear.

b. **Planning Considerations.** All retrogrades are difficult and inherently risky. To succeed, they must be well organized and well executed. A retrograde operation requires the following elements.

- (1) **Leadership and morale.** Maintenance of the offensive spirit is essential among subordinate leaders and troops in a retrograde operation. Movement to the rear may be seen as a defeat or a threat of isolation unless soldiers have confidence in their leaders and know the purpose of the operation and their role in it.
- (2) **Reconnaissance, surveillance, and security.** Timely and accurate intelligence is especially vital during retrograde operations. Reconnaissance and surveillance must locate the enemy so that security elements can deny him information and counter his efforts to pursue, outflank, isolate, or bypass all or a portion of the task force. The commander must constitute a security force that is strong enough to —
 - Secure enemy avenues of approach.
 - Deceive the enemy and defeat his intelligence efforts.
 - Overwatch retrograding units.
 - Provide rear guard, flank security, and choke point security.
- (3) **Mobility.** To conduct a successful retrograde, the task force seeks to increase its mobility and significantly slow or halt the enemy.
 - (a) The task force improves its mobility by—
 - Reconnoitering routes and battle positions.
 - Positioning air defense and security forces at critical points.
 - Improving roads, controlling traffic flow, and restricting refugee movement to routes not used by the task force.
 - Rehearsing movements.
 - Evacuating casualties, recoverable supplies, and excess materiel before the operation.
 - Displacing nonessential combat service support activities early in the operation.
 - Covering movements by fire.

- (b) The task force degrades the mobility of the enemy by—
 - Occupying and controlling choke points and terrain that dominate high-speed avenues of approach.
 - Destroying roads, bridges, and rafting on the avenues not required for friendly forces.
 - Improving existing obstacles and covering them with fire.
 - Employing indirect fire and smoke to degrade the enemy's vision and to slow his rate of advance. To ensure continuous coverage, task force mortars normally move in split sections.
 - Conducting spoiling attacks to keep the enemy off balance and force his deployment.
- (4) **Deception.** The objective of the deception is to hide the fact that a retrograde is taking place. This is essential for success. Deception is achieved by maintaining normal patterns of activity, such as radio traffic, artillery fires, patrolling, and vehicle movements. Additional considerations include using dummy minefield or decoy positions, and conducting feints and demonstrations under limited visibility conditions. Retrograde plans are never discussed on unsecure radio nets.
- (5) **Conservation of combat power.** The commander must conserve his combat power by —
 - Covertly disengaging and withdrawing less mobile units and nonessential elements before withdrawing the main body.
 - Using mobile forces to cover the withdrawal of less mobile forces.
 - Using minimum essential forces to provide security for withdrawal of the main body.

5-2. DELAY

A delay is an operation in which a force trades space for time while avoiding decisive engagement. The delay incorporates all of the dynamics of defense, but emphasizes preservation of the force and maintenance of a mobility advantage. The task force may attack, defend, or conduct other actions (such as ambushes and raids) during the delay to destroy the enemy or to slow his advance. The battalion task force may be given a delay mission as part of the covering force, as an economy-of-force operation to allow offensive operations in

another sector, or to control a penetration to set up a counterattack by another force.

a. Delay Missions.

- (1) A delay mission may be one of two types: delay in sector while avoiding decisive engagement, or delay forward of a specified line or position for a specified time. Examples of delay missions are:

TF 1-92 DELAYS IN SECTOR 151800B SEP _____ FROM NA _____ TO MR _____ TO MA _____ TO MB _____ TO DELAY THE ENEMY AS LONG AS POSSIBLE WHILE AVOIDING DECISIVE ENGAGEMENT.

or

TF 1-10 DELAYS IN SECTOR 030400A AUG _____ FROM NB _____ TO NB _____ TO NC _____ TO PREVENT THE ENEMY FROM CROSSING PL TIGER PRIOR TO 050400A AUG _____

- (2) Normally, a battalion task force delays in sector, and companies and platoons are assigned specific BPs to enhance command, control, and coordination across a wide area. In a delay, a determination must be made as to whether the preservation of the force or time is more important. This must be stated in the commander's intent.

b. Delay Fundamentals. The basic concept for delay is to retain freedom to maneuver while forcing the enemy to deploy repeatedly against successive battle positions. As the enemy uses artillery, deploys ground units, and begins maneuver, the delay force moves to subsequent battle positions to make the enemy initiate the same time-consuming process again. In doing this, the task force trades space for time. The delay is more difficult to execute if the initiative is left entirely to the enemy. Therefore, the task force commander must seize the initiative whenever possible. The following considerations are applied when planning and executing a delay:

- (1) **Centralize control and decentralize execution.** A delay is normally conducted on a wide front with maximum forces in contact and minimum forces in reserve. This results in a series of independent actions, and more consideration is given to attaching CS to companies.
- (2) **Maximize use of terrain.** Delay positions should be on terrain features that control the likely enemy avenues of approach. They should block the enemy where his movement is most canalized and facilitate maximum delay with minimum forces.

- (3) **Force the enemy to repeatedly deploy.** If possible, enemy reconnaissance elements will be ambushed. The enemy main body will normally be engaged at maximum range of all weapons to cause the enemy to deploy and maneuver. Repeated use of this technique slows the enemy and allows the commander to exchange space for time.
 - (4) **Maximize use of obstacles.** Reinforcing and existing obstacles are used on high-speed routes to slow the enemy's progress and to gain time for disengagement. To be effective, obstacles (including FASCAM) must be covered by fire.
 - (5) **Maintain contact with the enemy.** Continuous reconnaissance must be conducted to maintain contact with the enemy. Enemy forces will attempt to bypass, to envelop the flanks, or to penetrate between units conducting the delay. To prevent penetration or envelopment, contact must be maintained with all enemy forces encountered.
 - (6) **Avoid decisive engagement.** In a delay action, positions must be occupied long enough to force the enemy to deploy and maneuver. Disengagement criteria must be specified. The delay force moves from one delay position to another without becoming decisively engaged with the enemy unless required.
- c. **Delay Planning.** The following are planning considerations for development of courses of action to accomplish the delay mission:
- (1) Delaying forces must maintain a mobility advantage over the attacker. Enemy closure rates for the terrain should be calculated during wargaming and compared to friendly displacement rates between positions. Time-distance factors dictate the amount of time the commander has to engage the enemy and move his unit before becoming decisively engaged; these factors should be calculated for each avenue of approach. Situational templates must tell the commander where the enemy will be at certain times and help him decide where to emplace obstacles, and if or where decisive engagement is likely. The commander must use clearly defined decision or trigger points for displacing. This includes trigger points for employment of indirect fires and mortar displacement.
 - (2) Obstacles must slow the enemy long enough for the task force to engage and displace.
 - (3) Sectors of responsibility or battle positions are assigned to each committed company.

- (a) When using sectors, the task force commander assigns each likely enemy battalion avenue of approach in its entirety to one company. Boundaries are assigned so that terrain features that control fire and observation into a sector belong to the unit having responsibility for the sector. Contact and coordinating points are designated.
 - (b) If the terrain is suitable, battle positions are preferred in the delay.
- (4) The graphic control measures a commander chooses are key portrayals of his intent. Control measures used in the delay usually include —
- Phase lines of all higher commands.
 - Supplemental phase lines.
 - Checkpoints.
 - Battle positions and sectors.
 - Engagement areas and target reference points.
 - Contact points.
 - Passage points.
 - Assembly areas, main supply routes, and logistics release points.
 - Coordinating points.
 - Routes and lanes.

d. Delay from Successive Positions.

- (1) Delay from successive positions involves fighting rearward from one position to the next, holding each as long as possible or for a specified period. In this type of delay, all company teams are normally committed on each of the battalion task force delay positions or across the sector on the same phase line (see Figure 5-1, page 5-8).
- (2) Delay from successive positions is used when a sector is so wide that available forces cannot occupy more than a single line of positions. The disadvantages of this delay are lack of depth, less time to prepare subsequent positions, and possible occurrence of gaps between units. When ordered to move, the task force disengages, moves, and occupies the next designated position.

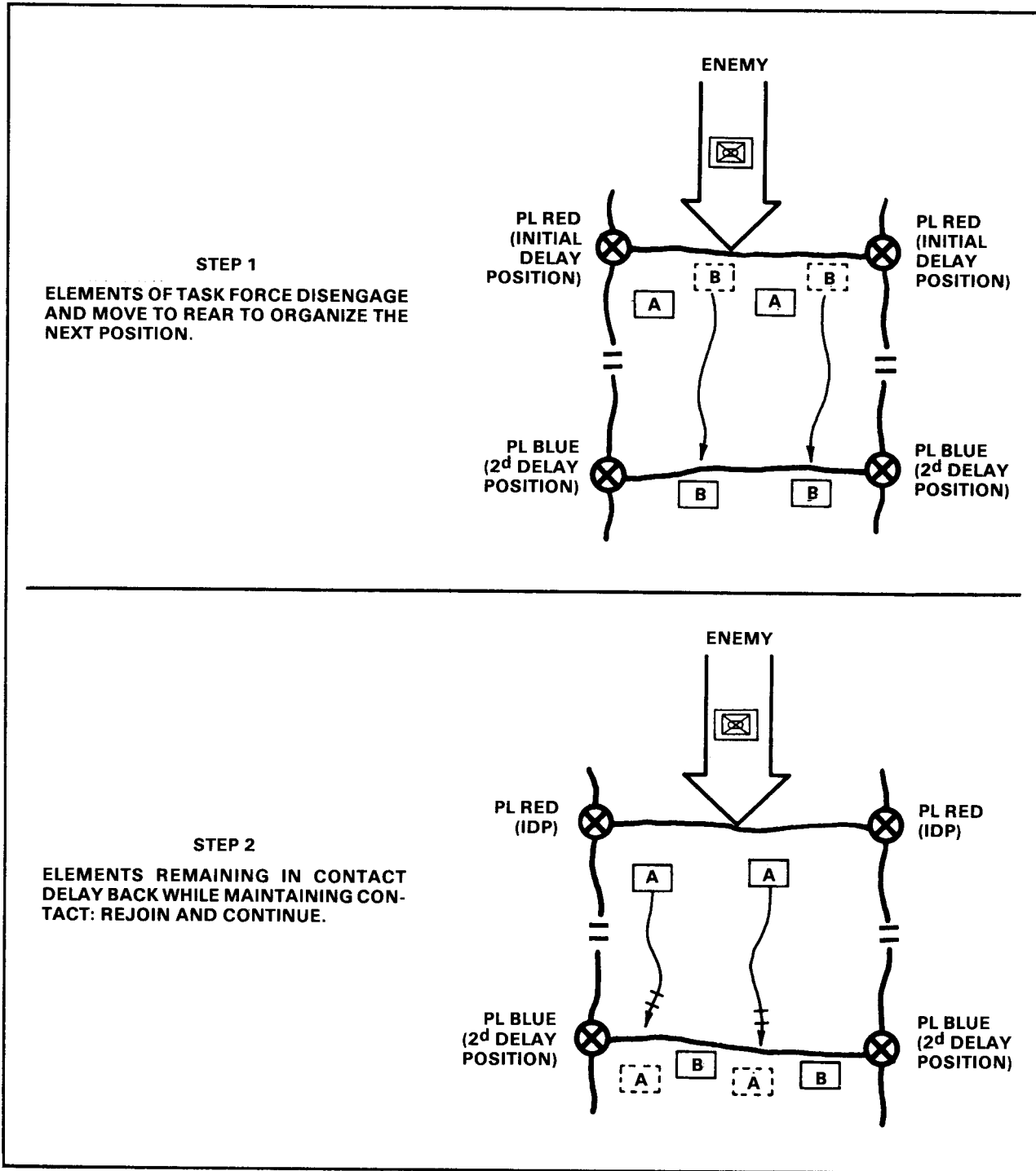

Figure 5-1. Delay from successive positions.

- (3) When the order to delay back is received, a portion of the unit concerned displaces directly to the rear and occupies the next designated position. The remainder of the unit maintains contact with the enemy between the first position and the next delay position. As these elements pass through, the enemy is engaged at maximum effective range from the next delay position. When the battalion task force is no longer able to hold the position without becoming decisively engaged, it moves to the next successive position.

e. Delay from Alternate Positions.

- (1) Delay from alternate positions may be used when a task force has a narrow sector or has been reinforced to allow positioning in depth. Employing this method, one or more company teams occupies the initial delay position and engages the enemy while the other teams occupy and prepare a second delay position. These elements alternate movement in the delay. While one element is fighting, the other occupies the next position in depth and prepares to assume responsibility for the fight.
- (2) Units occupying the initial delay position delay between it and the second delay position. When the delaying units arrive at the second delay position, they move through or around the units that are occupying the second position, and occupy the third delay position. Responsibility for delaying the enemy is assumed by the units on the second delay position. The delaying procedure is then repeated. Moving around the unit on the next delay position is preferred because this simplifies passage of lines (see Figure 5-2, page 5-10). Figure 5-3, page 5-11, provides a comparison of key considerations for use when determining the method of delay to be used.

f. Delay Position Selection.

- (1) A reconnaissance of delay positions is made as early as possible. Likely avenues of approach are determined, and plans are made to deny their use to the enemy. The commander selects positions that allow long-range fields of fire with routes suitable for rearward and lateral movement, and he establishes priorities of movement on these routes. Positions should incorporate as many of the following characteristics as possible:
 - Good observation and long-range fields of fire.
 - Covered or concealed routes of movement to the rear.
 - A road net or areas providing good cross-country trafficability.

- Natural (or reinforcing) obstacles on the front and flanks.
- (2) The commander assigns company team sectors astride likely enemy avenues of approach. Where possible, a company team is assigned a BP covering one major avenue of approach and the terrain dominating that avenue.
 - (3) The reserve is located initially in an area from which it can counterattack or move rapidly to reinforce.
 - (4) The battalion task force main CP and combat trains are well to the rear and normally behind the next rearward phase line. The tactical CP remains well forward in positions best suited to control the operation.

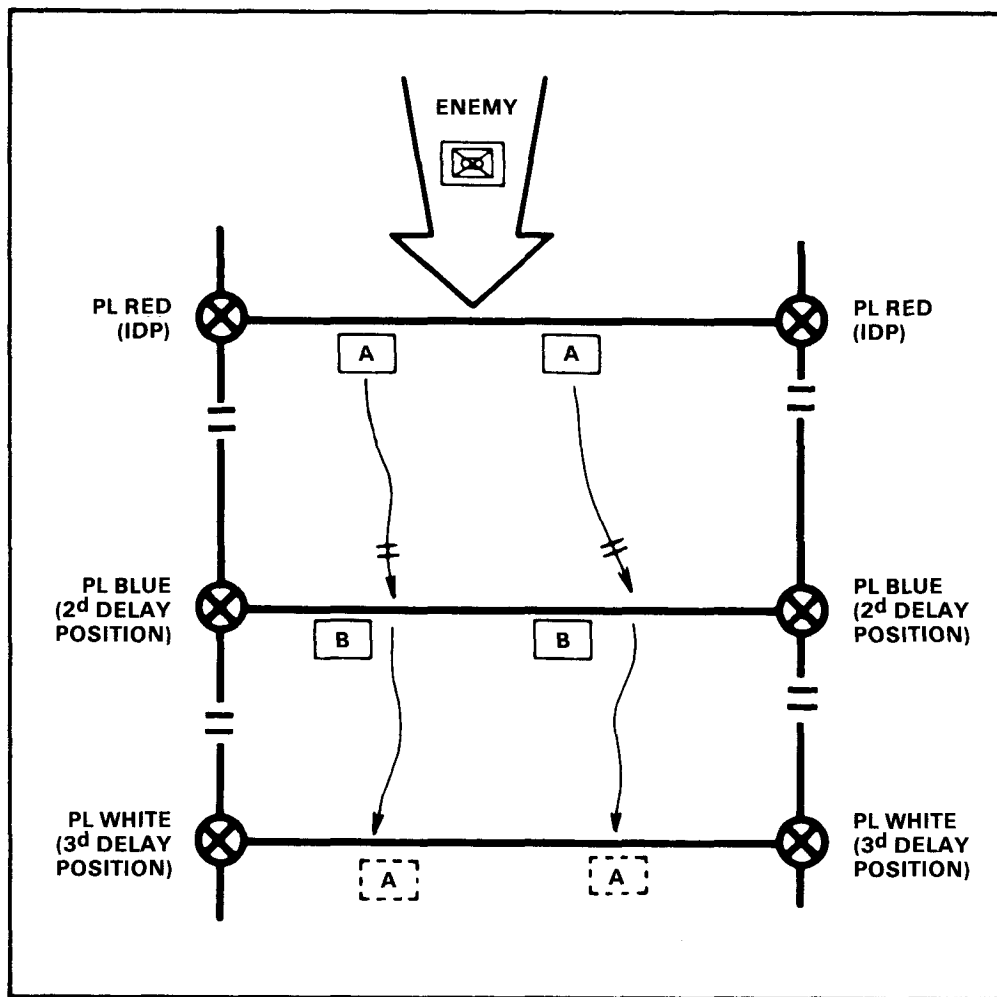

Figure 5-2. Delay from alternate positions.

METHOD OF DELAY	USE IS FAVORED WHEN:	ADVANTAGES	DISADVANTAGES
Delay from successive positions	<ul style="list-style-type: none"> — Sector is wide. — Forces available do not allow split operations. 	<ul style="list-style-type: none"> — Increased ability to mass fires. 	<ul style="list-style-type: none"> — Limited depth to the delay positions. — Less time available to prepare each position. — Less flexible.
Delay from alternate positions	<ul style="list-style-type: none"> — Sector is narrow. — Forces are adequate for split positions. 	<ul style="list-style-type: none"> — Allows positioning in depth. — Allows more time for equipment and soldier maintenance. 	<ul style="list-style-type: none"> — Requires continuous coordination. — Requires passages of lines.

Figure 5-3. Comparison of methods of delay.

- g. **Conduct of the Delay.** A commonly used sequence for the conduct of a delay is depicted as follows:
- (1) Initial delay positions are occupied, security and OPs are established, and priority of work is determined. Creating the illusion of a determined defense increases the amount of delay obtained.
 - (2) As the enemy approaches, long-range fires are used to inflict casualties, to disorganize him, and to force him to stop. If possible, enemy reconnaissance elements and advanced guard are destroyed by counterreconnaissance or ambushed.
 - (3) Each position occupied by a forward unit is defended until the enemy threatens an assault or envelopment of that position. Decisive engagement is avoided.
 - (4) The task force commander recommends to the brigade commander the appropriate time to move from brigade-designated delay positions. He moves on the basis of prearranged times, trigger points, or other decision criteria; on order, or when appropriate based on his commander's intent. He coordinates movement with higher and adjacent units. The task force moves only after considering the following.
 - (a) What is the strength, composition, and location of the enemy attacking force? Are elements of the task force threatened with decisive engagement or bypass?
 - (b) What is the status of adjacent units? How does their status affect the task force's capability to continue to delay?

- (c) What is the condition of the delay force in terms of losses in men, equipment, and morale?
 - (d) How strong is this particular position in relation to other positions that may be occupied?
 - (e) Is unit survivability or time key to the mission?
- (5) When maximum delay has been achieved, movement to the next delay position begins. Coordination of fires and recognition signals between the moving element and adjacent, supporting, and overwatch elements is an important task.
- (6) If elements of the task force are threatened with decisive engagement or have become decisively engaged, the commander may take several actions to facilitate their disengagement. In order of priority, he may do any of the following.
- (a) Allocate priority of all indirect supporting fires to the threatened unit. This is the most rapid and responsive method of increasing combat power of the unit.
 - (b) Direct adjacent units to engage enemy targets forward of the threatened unit. This may require repositioning of units adjacent to or behind the threatened unit.
 - (c) Reinforce the unit.
 - (d) Conduct a counterattack to disengage.
- (7) To redesignate a reserve, the task force commander designates the least engaged force to perform reserve missions, especially when delaying on successive positions. The reserve may also consist of an element in depth. When assigned multiple missions, the reserve force must be given priority of missions for planning. Reserve missions are —
- Reinforcing.
 - Assisting in disengagement.
 - Providing overwatch.
 - Assuming another unit's mission.
 - Counterattacking.
 - Blocking.
- (8) Each delay must end with a planned operation such as a defense, a withdrawal, or an attack.

5-3. WITHDRAWAL

A withdrawal is an operation in which all or part of the battalion frees itself for a new mission. A withdrawal is conducted to break contact with the enemy when the task force commander finds it necessary to reposition all or part of his force or when required to attain separation for employment of special purpose weapons. It may be executed at any time, during any type of operation. There are two types of withdrawals — withdrawal not under enemy pressure and withdrawal under enemy pressure. Both types begin while the battalion is under the threat of enemy interference. Preferably, withdrawal is made while the battalion is not under heavy enemy pressure.

Withdrawals are either assisted or unassisted. An assisted withdrawal uses a security force provided by the next higher headquarters to assist the main body in breaking contact with the enemy and to provide overmatching fires. In an unassisted withdrawal, the task force provides its own security force.

a. **Planning Considerations.** Planning considerations for the withdrawal are the same as for the delay. Withdrawals are accomplished in three overlapping phases.

- (1) **Preparatory phase.** Reconnaissance and quartering elements are dispatched, warning orders are issued, and planning is initiated. Trains, main CP elements, and nonessential vehicles are relocated to the rear.
- (2) **Disengagement phase.** Designated elements begin their movement to the rear. When contact with the enemy is broken, they assemble and conduct a tactical movement to a designated assembly area or position.
- (3) **Security phase.** A detachment left in contact (DLIC) assists disengagement of other elements, assumes responsibility for the battalion sector, deceives the enemy, and protects the movement of disengaged elements with maneuver and fires. This phase ends when the DLIC completes its movement to the rear.

b. **Withdrawal Not Under Pressure.**

- (1) A withdrawal not under enemy pressure depends on speed of execution and deception. If the task force is not under attack, then withdrawal is not under enemy pressure. Deception and operations security are essential to success. The enemy must not be aware that a withdrawal is taking place.

- (a) Deceptive measures used are—
 - Simulating or continuing normal activities, with a DLIC that deceives the enemy into believing that defending forces are still in position.
 - Continuing communications in a normal manner.
 - Continuing patrolling activity.
 - Using limited visibility to cover withdrawal.
- (b) Operations security complements the deception effort. Nothing is transmitted that might compromise the intention to withdraw. Noise and light discipline is maintained. Movements may be masked by artillery fire, and counterreconnaissance activities are continued.
- (2) Before the withdrawal, a thorough reconnaissance is conducted, and control measures are established to ensure control. Each company's key leaders need to know the plan of withdrawal in detail and should participate in the leader's reconnaissance. The leaders reconnoiter the start points, routes, release points, and assembly areas (see Figure 5-4). Reconnaissance should be conducted during a condition of visibility that approximates the withdrawal conditions.
- (3) The task force commander states the following in the operation order:
 - When the withdrawal will start.
 - Where the task force assembly area is (if used) and what each company team is to do upon arrival there.
 - The location of each company team assembly area.
 - What routes to take from the company team assembly areas to the task force assembly area, or to the next position.
 - The DLIC's size, composition, mission, and commander.
 - Subsequent task force and company team missions.
- (4) In an assisted withdrawal, the brigade establishes a security force. The task force commander withdraws behind this force.
- (5) In an unassisted withdrawal not under pressure, a DLIC is organized from elements from each company in contact with the enemy. Command and control of the DLIC is exercised to closely simulate normal task force activities. The task force S3 is in charge of the battalion DLIC, with company XO's in charge of their respective DLICs. The task force commander may leave a company team intact as the

DLIC. When that occurs, elements of the company team are repositioned to cover the entire task force sector. When the main danger is on a single company team's approach, the task force commander may leave that team in position and attach security elements from the other approaches to it.

- (6) The task force commander determines the size and composition of the DLIC based on METT-T. The DLIC is able to detect the enemy, deceive him, and engage him on all avenues of approach with both direct and indirect fires.

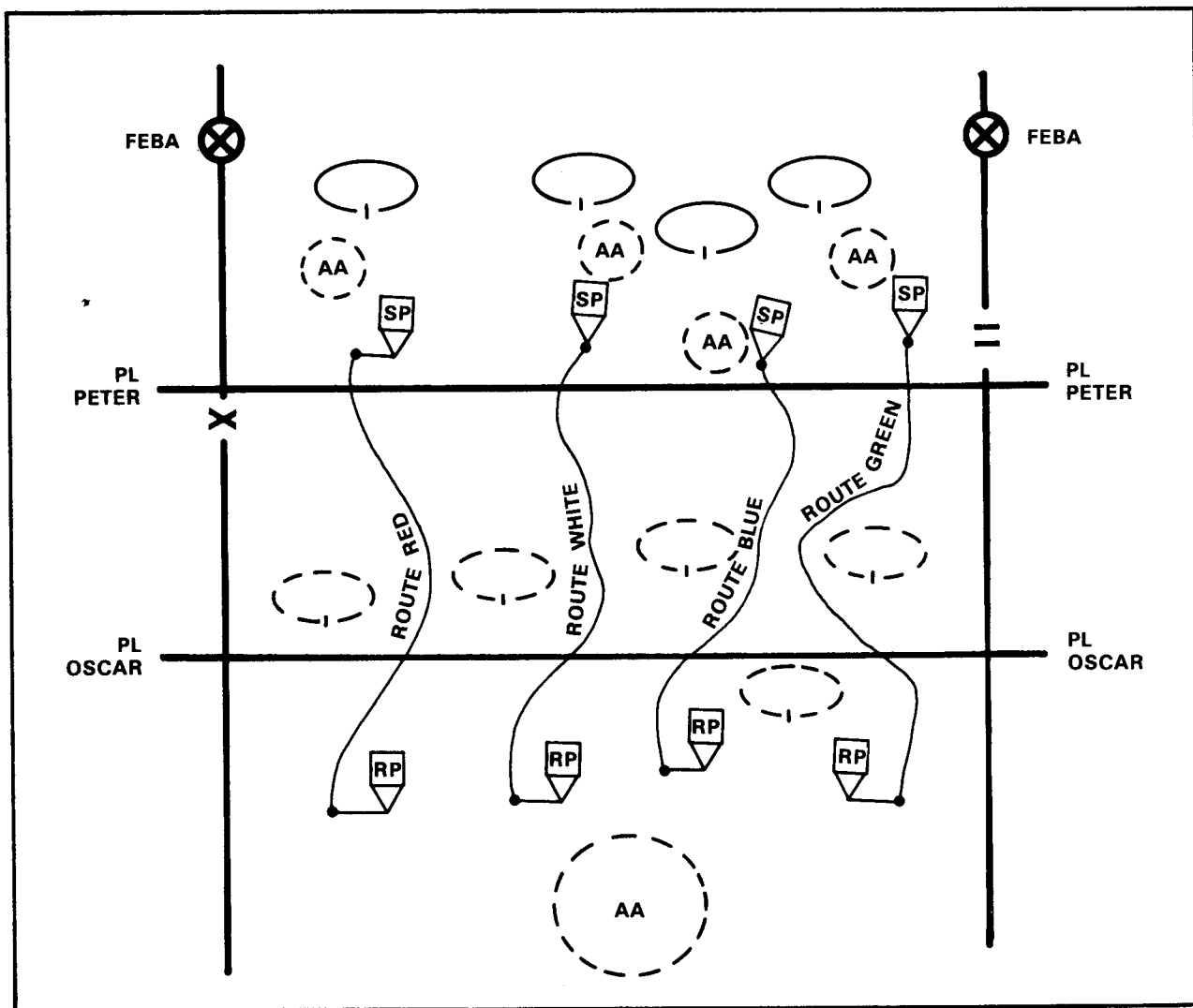

Figure 5-4. Control measures for withdrawal not under pressure.

- (7) The main body of the task force is composed of the remaining maneuver, combat support, and control elements. Its mission is to displace using stealth, move along designated routes, assemble, and move to a new location in preparation for the next mission.
- (8) Reserves or units positioned in depth within the battalion sector may coordinate withdrawal before, during, or after the displacing elements of the forward companies. Generally, they will withdraw after these elements. This increases flexibility and security in the event the enemy detects the withdrawal and attacks.
- (9) The main body moves on designated routes to the next position according to priorities established by the task force commander. Main body elements may also be given on-order missions to defend, delay, or counterattack during the withdrawal (see Figure 5-5).

c. Withdrawal Under Pressure.

- (1) A withdrawal under enemy pressure depends on maneuver and firepower to break contact as the enemy attacks the task force. A reconnaissance is conducted to the rear to identify routes that offer the best cover and concealment and to determine engineer assistance required to overcome obstacles. The planning closely resembles that of the delay in regard to the use of available organic and nonorganic assets.
- (2) The task force commander should prescribe specific control measures (see Figure 5-6, page 5-19) to maintain order during the withdrawal under enemy pressure. These measures may include—
 - Sectors.
 - Battle positions.
 - Phase lines.
 - Routes.
 - Passage lanes or passage points.
 - Contact points.
 - Checkpoints.
 - Battle handover line.
- (3) Success of the withdrawal under pressure depends on facilitating disengagement of the main body by massing its own fires and overmatching fires provided by a security force.

The brigade commander may place adjacent units or a reserve in overwatch, or may require them to conduct security operations or limited counterattacks to support the withdrawing task force.

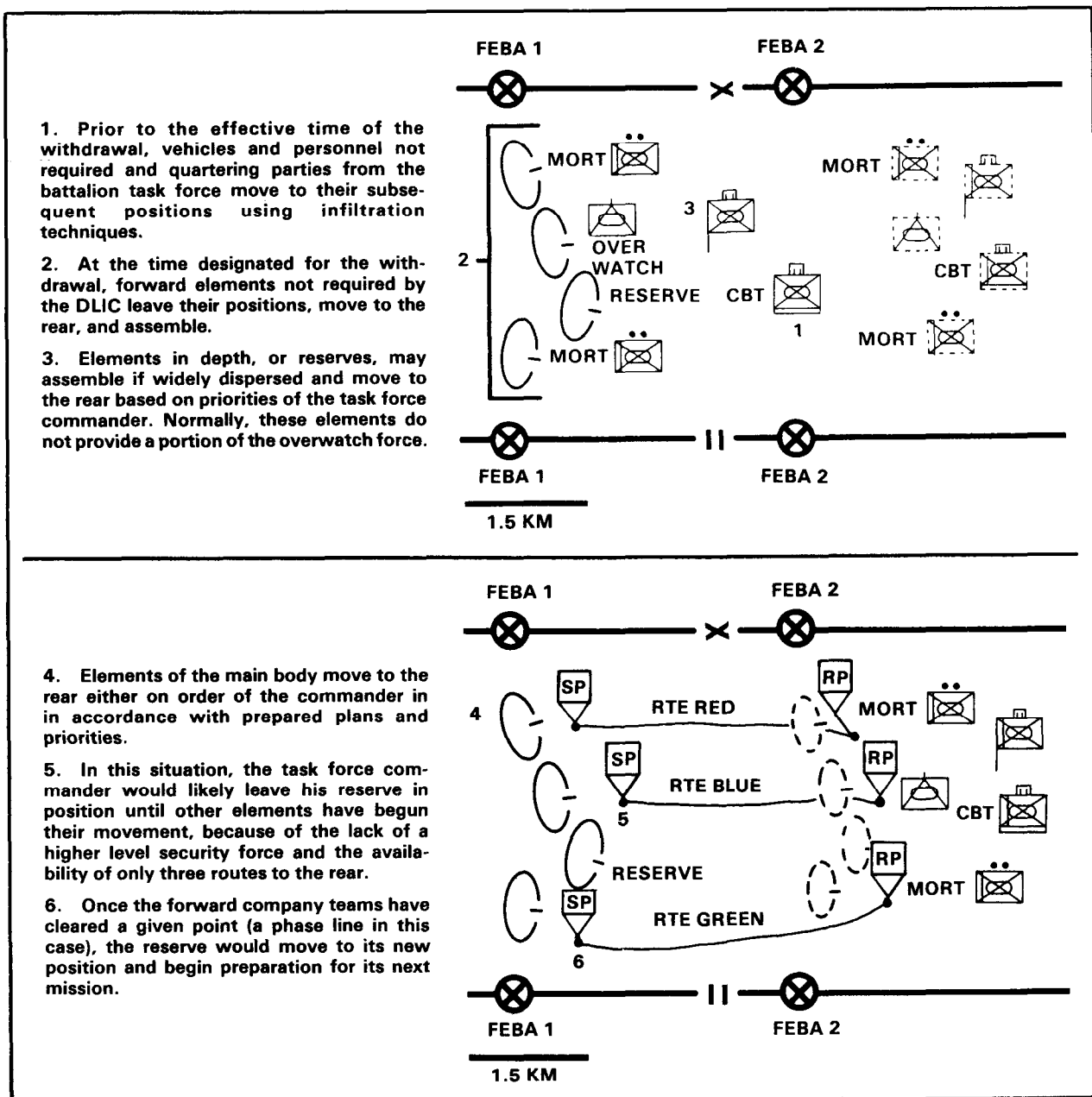

Figure 5-5. Withdrawal not under enemy pressure.

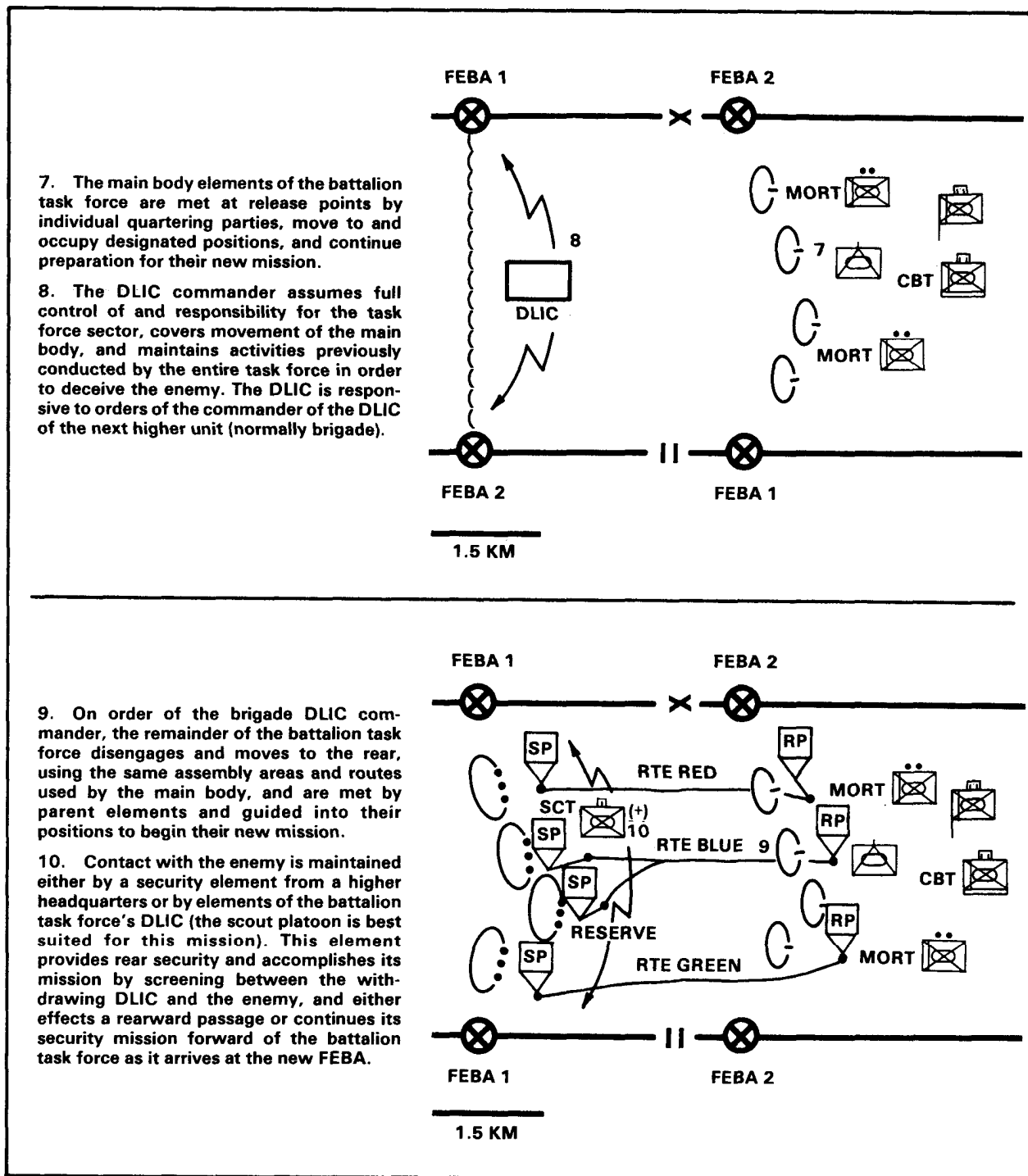

Figure 5-5. Withdrawal not under enemy pressure (continued).

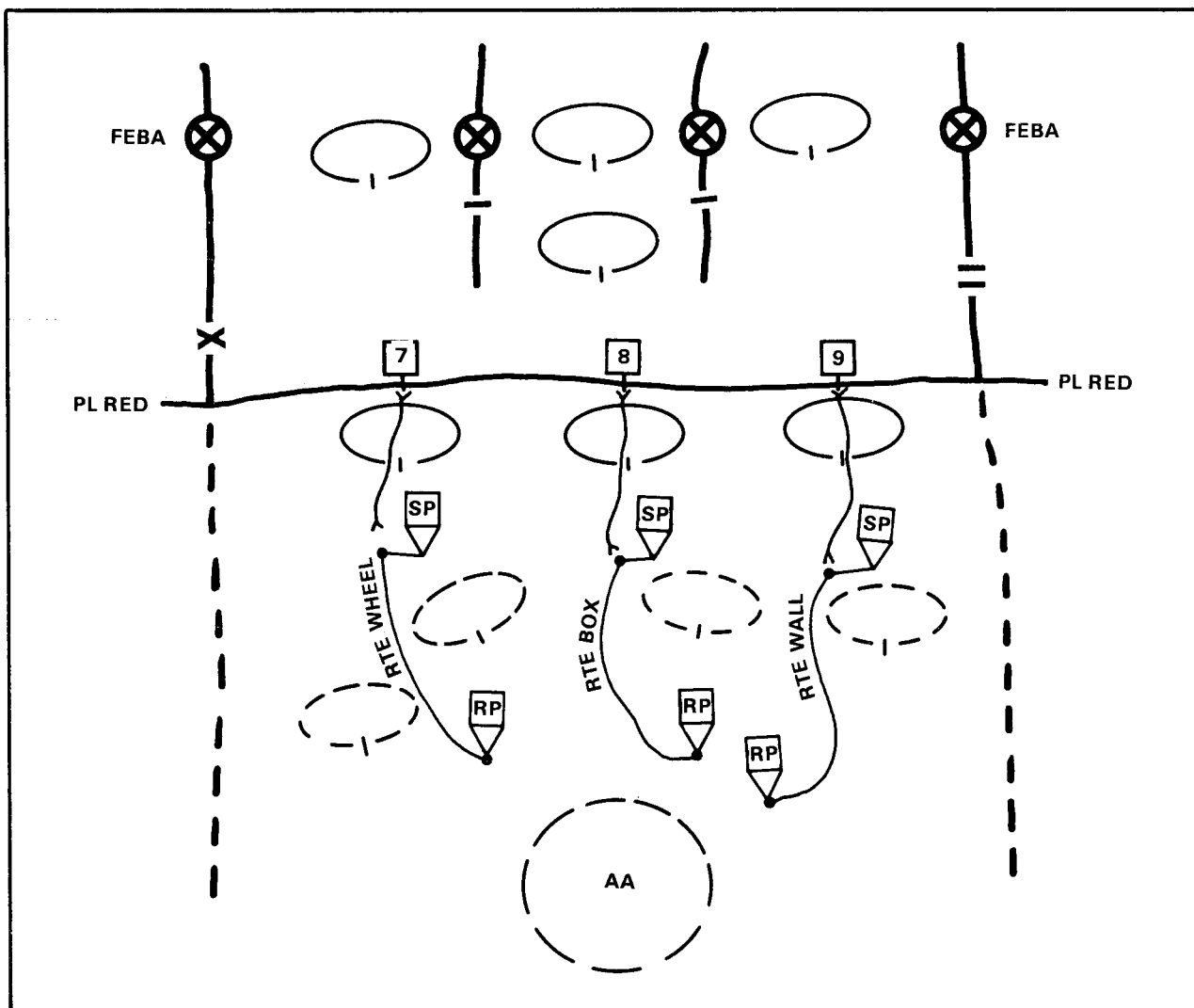

Figure 5-6. Control measures for withdrawal under enemy pressure.

- (4) To assist withdrawing elements, the security force must be strong enough to detect and engage the enemy on all avenues of approach. The task force may form its own security force from forward company team elements. Missions of the security force are —
- Stop, disrupt, disorganize, or reduce the enemy's capability to pursue.
 - Reduce, through smoke and suppressive fires, the enemy's capability to observe movement of the task force.

- Rapidly concentrate additional combat power in critical areas.
- (5) As the order to withdraw is given, the battalion must engage the enemy with concentrated direct and indirect fire to enable the withdrawing force to disengage, conduct a rearward passage through the security force, assemble, and move to their next position.
- (6) The security force assumes the fight from the forward elements. This includes delaying the enemy advance while the bulk of the task force conducts movement to the rear. On order or when other predetermined criteria are met, the security force disengages itself and moves to the rear as a rear guard. Depending on the task force's next mission, the security force may be required to maintain contact with the enemy throughout the operation.

5-4. RETIREMENT

- a. A retirement is a retrograde operation in which a force that is **not in contact** with the enemy moves to the rear in an organized manner. A retirement is usually made at night. If enemy contact is possible, on-order missions are given to the march units.
- b. A retirement may have an adverse impact on the morale of friendly troops. Leadership must be positive and must keep troops informed of the purpose of the retirement and future intentions of the chain of command.
- c. A task force conducts a retirement as part of a larger force.

Section II. PASSAGE OF LINES

A passage of lines is an operation in which one unit is passed through the positions of another. When a unit moves toward the enemy through a stationary unit, it is a forward passage. Rearward passages are movements away from the enemy through friendly units. The covering force withdrawing through the main battle area, or an exploiting force moving through the initial attacking force, are examples.

5-5. PURPOSE

- a. A passage of lines is necessary when one unit cannot bypass another. A passage of lines may be conducted to:

- Continue an attack or counterattack.
 - Envelop an enemy force.
 - Pursue a fleeing enemy.
 - Withdraw covering forces or main battle.
- b. The task force is vulnerable during a passage of lines. As units are concentrated, the fires of the stationary unit may be masked and the task force is not disposed properly to react to enemy action. Detailed reconnaissance and coordination are key to ensure a quick and smooth passage.

5-6. PLANNING CONSIDERATIONS

The commander of the passing unit makes a tentative plan for the conduct of the operation as follows.

- a. **Organization.** Task organization is determined and effected before movement to passage.
- b. **Order of Movement.** An order of movement is prescribed, based on the scheme of maneuver once passage is completed, the number of passage points, the degree of security required, the enemy situation, and the terrain. A movement order precludes confusion and congestion by setting priorities on unit movements.
- c. **Command and Control.**
- (1) Multiple passage points and routes are established with centralized control. To ensure coordination of passage with a minimum of confusion and misunderstanding, the command groups of the passing and stationary units are collocated. In this manner, the FSOs and FACs of the two units can coordinate and pass responsibility in accordance with the commanders' guidance.
 - (2) In a forward passage of lines, the commander of a passing unit assumes responsibility for the zone of attack when his lead elements reach the release point(s) of the passage lanes. In a rearward passage of lines, the responsibility for a sector normally changes when the passing unit lead elements enter the passage lane or cross the battle handover line, whichever comes first. Responsibility may also be event-related, based on the passage of a specific number of companies through the passage points. Coordination and control of the task force through the passage points are facilitated if the boundaries of the passing unit and the stationary unit coincide.

- d. **Control Measures.** Within the area of passage, the same control measures should be used by both passing and stationary units. Control measures include—
 - Assembly areas.
 - Battle handover line (BHL).
 - Attack position.
 - Passage lanes.
 - Passage point.
 - Time of passage.
 - Recognition signals.
 - Contact point.
 - Routes, including start and release points.
- e. **Fire Support.** Direct and indirect fires of the stationary unit are integrated into the fire support plan of the passing unit. Command and control may be collocated to provide coordinated and responsive support. All direct and indirect fire support responds directly to the commander responsible for the zone of action.
- f. **Reconnaissance.** A thorough reconnaissance covers routes to, through, and beyond the area of passage. The reconnaissance should note existing and proposed troop locations. A technique to ensure deception during a forward passage is to limit the number and size of reconnaissance parties and use vehicles of the stationary unit.
- g. **Coordination.** During the planning process, commanders and staffs of the units involved coordinate the following:
 - Exchange of intelligence.
 - Exchange of tactical plans.
 - Exchange of signal operation instructions (SOI) information.
 - Arrangements for reconnaissance.
 - Security measures during the passage.
 - Selection of areas of passage and provisions for guides.
 - Priorities for routes and facilities, including provisions for movement control. The passing unit has priority.
 - Time or circumstances when responsibility for the control of the area of operations is transferred.
 - Fire and other combat support to be provided by the unit in contact.

- Combat service support to be provided by the unit in contact, including medical, maintenance, and recovery assistance.
- Exchange of liaison personnel.
- Exchange of information on minefield and other obstacles.
- Command relationship between the passing unit's CS and CSS assets and the unit in contact, including site locations.
- Tactical cover and deception plans.

5-7. REARWARD PASSAGE

This paragraph implements STANAG 2082 (Edition 5), paragraph 5c.

- a. The commander of the stationary unit designates the contact point for coordination and notifies the passing unit of its location, if this has not been designated by higher headquarters. The stationary unit eavesdrops on the forward unit's net to stay abreast of the tactical situation.
- b. The contact point is normally on an easily identifiable terrain feature forward of the battle handover line. At the prescribed time, liaison parties from the two units meet and do the following:
 - (1) Exchange:

This subparagraph implements STANAG 2129 (Edition 3), paragraph 6c(1).

- Latest enemy information (size and type of force, location and direction of movement).
 - Recognition signals.
 - Signs and countersigns.
 - SOI information.
- (2) Verify:
- Provisions for and placement of guides.
 - Estimated time of main body arrival, and numbers and types of vehicles to pass.
 - Time or event for battle handover.
 - Minefield and obstacle information.
 - Passage points, lanes, and alternates.

- (3) Coordinate:
- Passed force's security force positions to support the handover.
 - Supporting direct and indirect fires.
- c. Scouts of the stationary unit screen along the battle handover line and monitor the passing unit's command net.
 - d. After verification that the passage points are occupied, scouts or liaison parties make contact at each passage point. The passing unit's scouts must know which units are to pass through their respective passage points. The passing unit will pass in order CSS elements, main CP, combat support elements, tactical CP, and combat units. For ease of control, the passing unit temporarily collocates its tactical CP with the tactical CP of the stationary unit near the FEBA.
 - e. The passage points should be manned with the passing task force scouts and representatives from the forward companies of the stationary units. Lanes through obstacles are marked and provisions are made to quickly close them. Both scout platoon leaders collocated near the battle handover line monitor the progress of the passage and are not distracted with the requirement to man passage points. The stationary unit scout platoon may not have sufficient combat power to screen the battle handover line. Additional combat power can be obtained by placing a tank or antiarmor platoon under OPCON of them or by using a company team in lieu of the scouts. The scout platoon may be placed under OPCON of the company team. A composite force using scouts, antiarmor platoons, and a tank platoon may also be formed and placed under the command of the antiarmor company commander.
 - f. The mission of the unit on the battle handover line is to assume responsibility for the fight from the forward task force. If passing units are in contact, their maneuver elements must bound behind the BHL, covered by the passed unit. The passing units must quickly redeploy into column formation, display the proper visual signal, orient weapons toward the enemy, and move rapidly to the passage point and to the release point. Care must be taken to avoid friendly obstacles emplaced in the MBA. The BHL should also be far enough forward to allow the passing unit room to move into the column, yet close enough to permit overwatch by units along the FEBA (see Figure 5-7).
 - g. The stationary unit's scouts notify their forward company teams that friendly forces are at the BHL and are en route to the passage point.

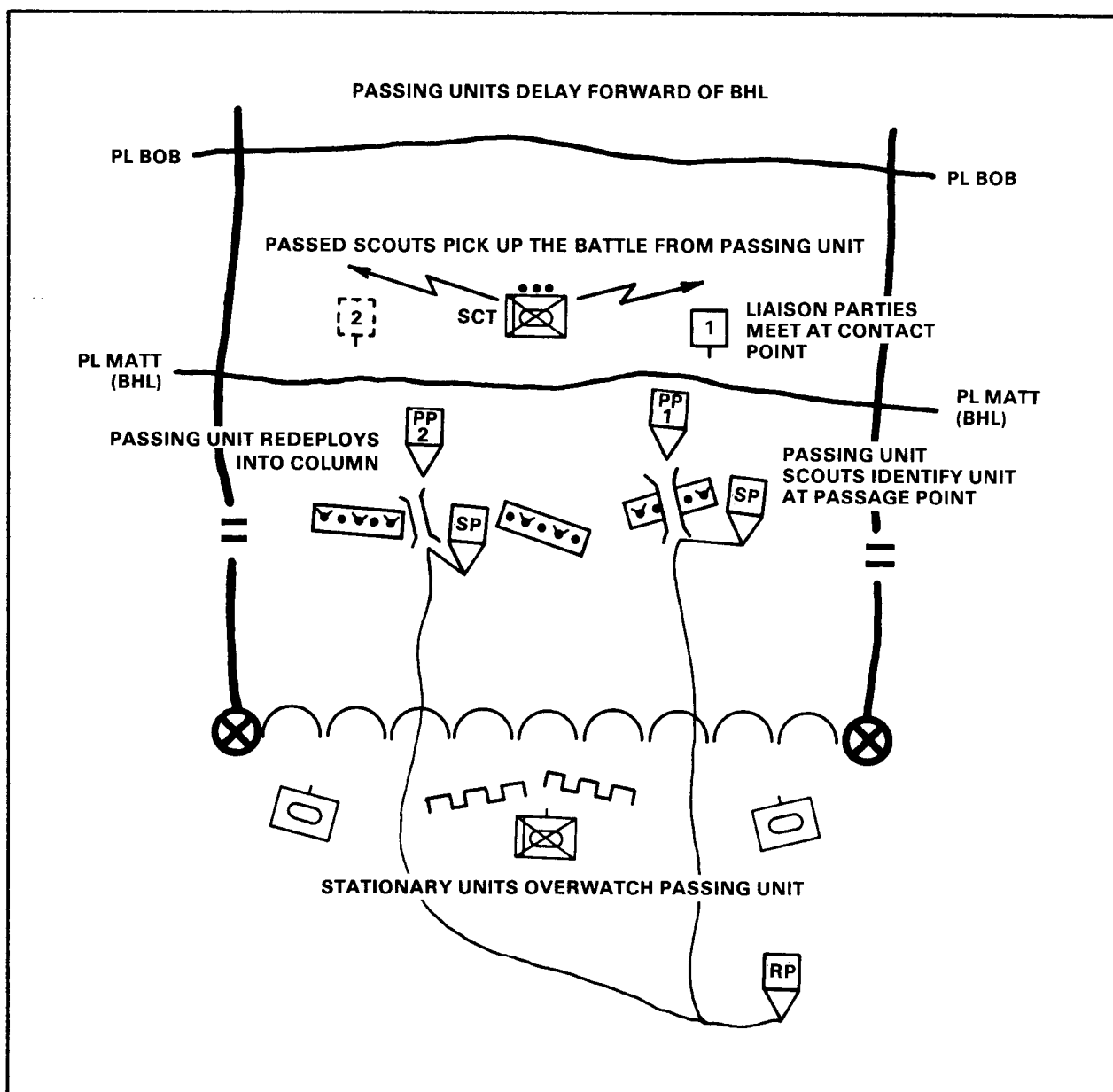

Figure 5-7. Battalion task force rearward passage of lines.

- h. The passing unit's vehicles move quickly through passage points and are led along the routes to the rear, while overmatched by the stationary unit. The stationary task force commander, company team commanders, and platoon leaders must carefully observe this passage. The only time the stationary unit should

fire is when positive enemy identification is made. The commander of the passing unit is responsible for identifying the last element of his command as it passes through the stationary unit's positions.

- i. Disabled vehicles are self-recovered, destroyed in place, or assisted by other elements of the passing unit. The stationary unit provides medical assistance, fuel, oil, lubricants, and maintenance as required after passage is complete.
- j. Because of potential congestion at passage points, passing units must move rapidly to minimize exposure time.

5-8. FORWARD PASSAGE

This paragraph implements STANAG 2082 (Edition 5), paragraph 5b.

- a. Upon receipt of the order to pass forward through another unit, the stationary and passing battalion task force commanders initiate actions similar to a rearward passage. The task force commander and/or S3 coordinates a forward passage. The critical information exchanged is the same as in a rearward passage, except the stationary unit will know more about the terrain and enemy situation than the passing unit (see Figure 5-8).
- b. The stationary unit commander is responsible for establishing the contact points, passage points, and routes, if they are not specified in the brigade order. As a minimum, the stationary commander provides guides at contact points to lead the passing unit to passage or release points near the FEBA or LD/LC.
- c. The passing unit main CP collocates with the main CP of the stationary unit. Passed forces maintain normal radio traffic. Passing company teams maintain listening silence on their task force command net. The stationary unit's guides notify their commander that movement of the passing force forward from the contact points has begun.
- d. The stationary force provides overmatching direct and indirect fires for the passing forces. The passing force FSO collocates with the stationary force FSO. The passing force heavy mortars are positioned by the passing force commander after coordination with the stationary commander. Fire missions are approved by the stationary unit FSO until sector responsibility is passed. After that, any fire missions for the stationary unit heavy mortar platoon are cleared through the passing unit FSO.

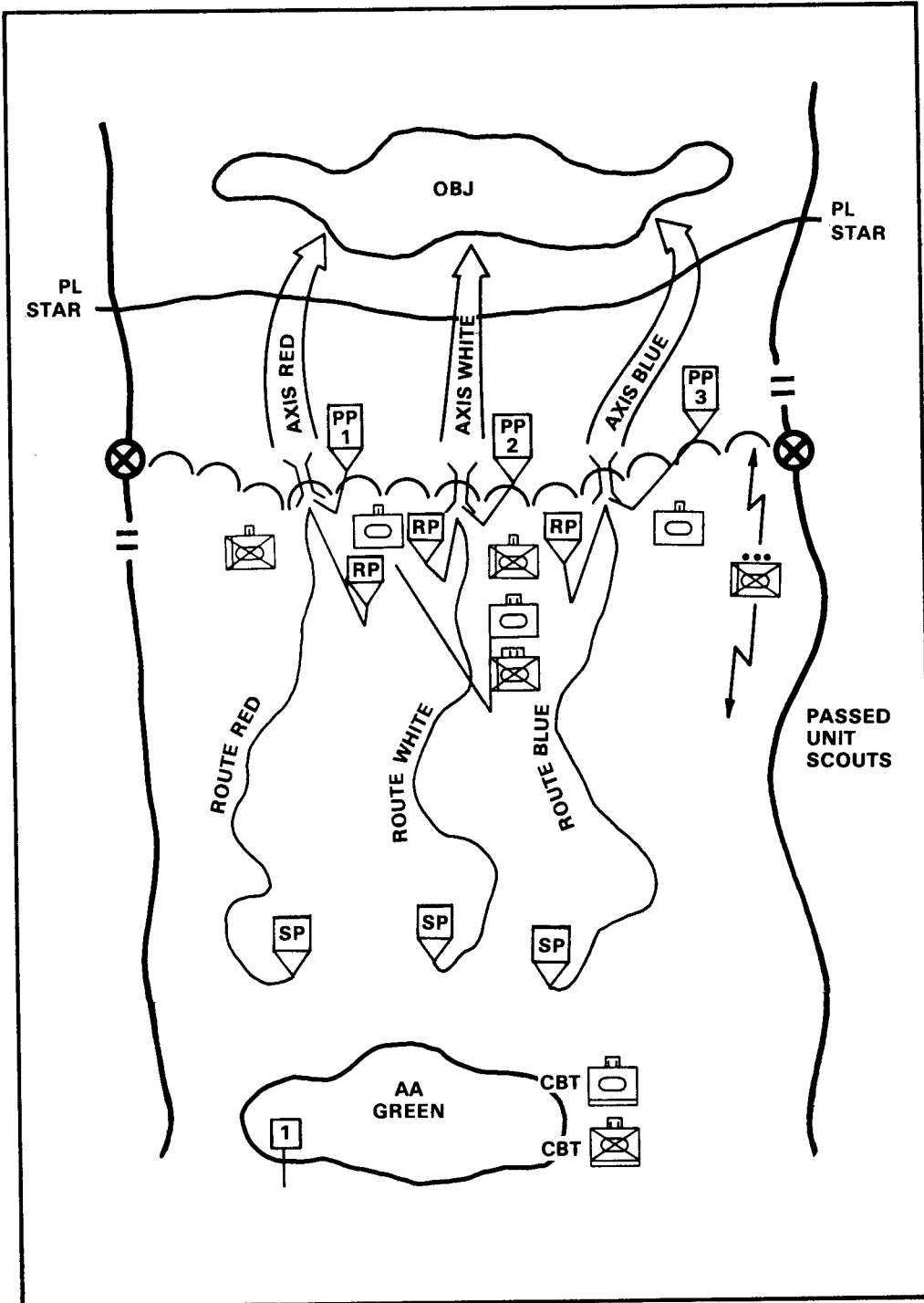

Figure 5-8. Forward passage of lines.

Section III. RELIEF OPERATIONS

This section implements STANAG 2082 (Edition 5), paragraph 5a and Annex A.

A relief is an operation in which a unit is replaced in combat by another unit. Responsibilities for the mission and assigned sector or zone of action are assumed by the incoming unit. Reliefs may be conducted during offensive or defensive operations and during any weather and light conditions. They are normally executed during limited visibility to reduce the possibility of detection.

5-9. PURPOSE

The purpose for relief is to maintain the combat effectiveness of committed elements. A relief may be conducted to —

- Reconstitute a unit that has sustained heavy losses.
- Introduce a new unit into combat.
- Rest units that have conducted prolonged operations.
- Decontaminate or provide medical treatment to a unit.
- Conform to a larger tactical plan or make mission changes.

5-10. TYPES

A unit may conduct a relief operation using one of the following:

a. Relief to Continue the Defense.

- (1) **Area relief.** The area relief is least common. It is conducted when units are dissimilar or when improved defensive terrain is away from the line of contact.
- (2) **Relief in place.** The relief in place is the most common and is used when units have similar organizations or when occupied terrain must be retained. This particular type of relief requires more time than the area relief. Additionally, the relief in place requires detailed planning and coordination, as the incoming unit will be assuming the same positions and missions of the outgoing unit.

b. Relief to Continue the Offense.

- (1) **Area relief.**
- (2) **Forward passage of lines.** This is the most common form of relief in the offense. It takes the least amount of time

and coordination. This form of relief also assists in maintaining the momentum of the attack.

- (3) **Relief in place.** This is the least common form of relief in the offense because of the detailed coordination and length of time it takes to conduct the operation.

5-11. CONDUCT OF THE RELIEF

a. Liaison.

- (1) Upon receipt of the order to conduct the relief, the task force commander and staff develop their estimates. The relieving unit establishes continuous liaison with the relieved unit immediately upon receipt of the relief order.
 - (a) The orders group moves to the main CP of the unit being relieved to coordinate the operation.
 - (b) The relieving unit XO supervises unit movement to an assembly area to the rear of the relieved unit.
- (2) Liaison involves coordination of the task force maneuver and fire support plan, and an intelligence update that includes past, present, and probable enemy action.

b. **Sequence of Relief.** The sequence of relief is from rear to front. Three different methods may be used to conduct the relief (see Figure 5-9, page 30). In determining which sequence will be used, particular attention is given to the combat effectiveness of the companies and their subsequent missions.

- (1) **Relieving units one at a time.** This method is the most time-consuming. The combat trains of the two units may be collocated to facilitate coordination and transfer of equipment, excess ammunition, fuel, water, and medical supplies. Relieving units maintain radio-listening silence and monitor the relieved unit's command net. Relieving task force scouts may initially be used as guides. When relief along the FEBA is complete, they move forward to relieve the scouts of the relieved unit.
- (2) **Relieving units simultaneously.** This method is the fastest, but sacrifices secrecy and causes confusion because all units move at once. When the command groups and combat trains are collocated and plans and equipment have been exchanged, the units of the relieving battalion task force move at once along designated routes. Relief occurs simultaneously at each location. Relieved units withdraw immediately once they are relieved; they do not wait for the other units of the task force.

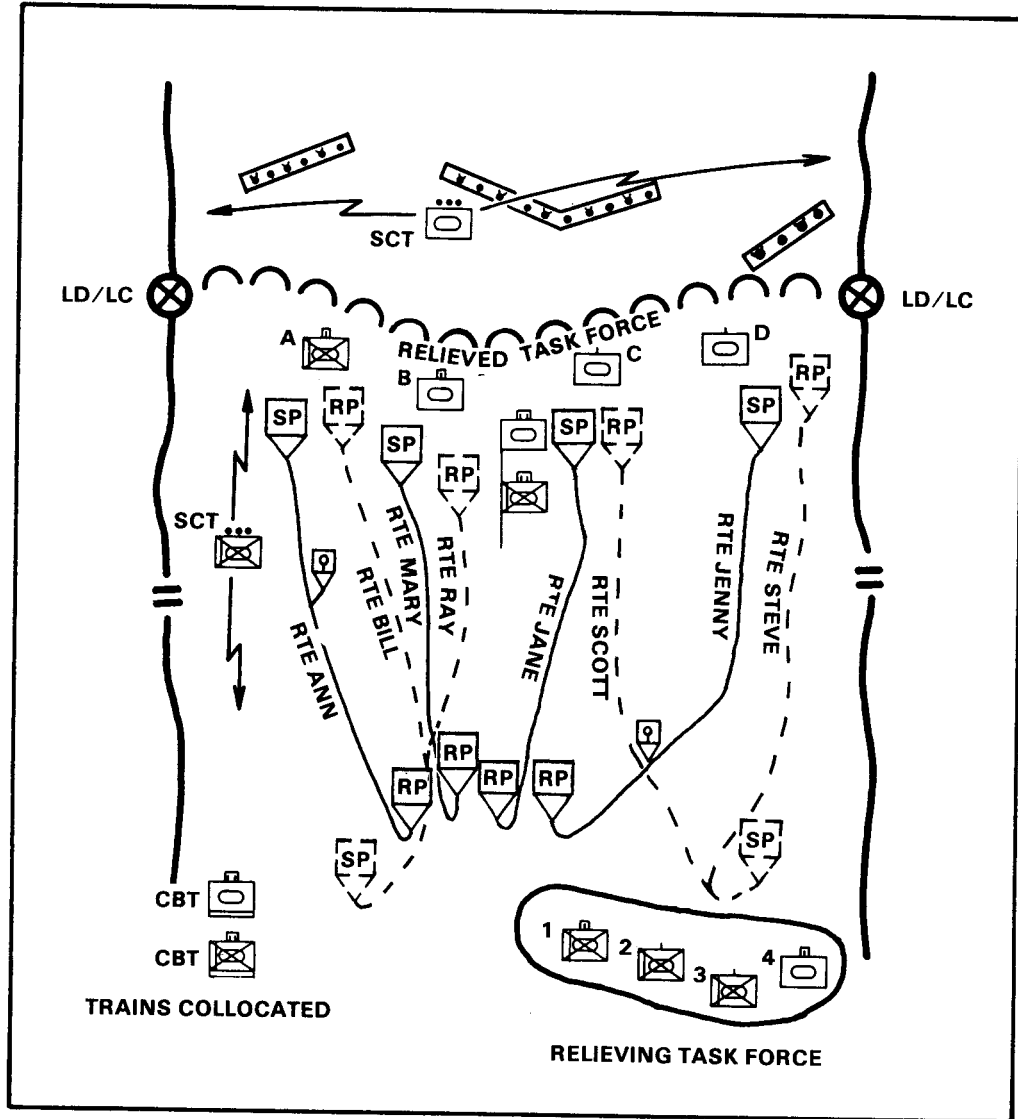

Figure 5-9. Relief of a task force.

- (3) Relieving by occupying in-depth or adjacent position (area relief). A relief in place can be conducted by occupying in-depth or adjacent positions. To facilitate this method, the relieving unit should be able to place direct fires on the other unit's direct fire control measures (TRPs, EAs). This method is particularly useful if the unit being relieved has been chemically or radiologically contaminated. The relieving unit maintains radio-listening silence until the responsibility of the sector or zone is passed. The unit being relieved maintains

normal traffic. Coordination between units is directed by higher headquarters and accomplished at brigade and/or division designated contact points. The relieved unit withdraws one unit at a time or simultaneously, depending on the situation.

- c. **Location and Types of Obstacles.** Unit obstacle locations are identified; minefield are recorded and verified; and minefield records are transferred.
- d. **Fire Support.** Detailed fire support coordination and liaison are conducted between the two units. Target lists are given to the incoming unit. If fire support assets are to be relieved, they are the first to collocate and the last to leave. Fire support assets of the relieved unit remain in position throughout the relief of maneuver units and are prepared to support both units throughout the relief. For example, mortar units and FISTs to be relieved remain in position until the relief of infantry units is completed. Range cards, target lists, and overlays should be given to the incoming unit to ensure the effective delivery of fire. Fire support assets of the relieving unit move into positions as quickly as possible so they can support both units during the relief.
- e. **Movement Control.**

This subparagraph implements STANAG 2082 (Edition 5), paragraph 6

Movement control is maintained by designating and ranking routes in priority order. Guides are positioned at critical points along the routes. Assembly areas (AAs) are designated and activities to be performed in these areas are specified. Separate AAs are designated for the incoming and outgoing units to minimize confusion. Time spent within AAs is minimized to avoid possible compromise.

- f. **Passage of Command.** The task force commanders mutually agree to the sequence of relief and for the passage of command. The passage of command normally takes place when one-half of the relieving unit is in position.
- g. **Enemy Contact during a Relief in Place.** If either unit gains direct fire contact with an enemy force, it immediately notifies the other unit and the higher headquarters directing the relief. If responsibility has not passed, the relieving unit immediately becomes under OPCON of the relieved unit. The relieving unit's mortars will fire missions as directed by the commander of the unit being relieved. If responsibility has passed, the relieved battalion task force commander and staff may become under OPCON of the relieving unit. The presence of collocated CPs

facilitates rapid coordination and action if enemy contact is encountered during the relief. Unity of command is imperative.

h. **Exchange of Equipment.** When a relief is conducted during limited visibility, grounded crew-served weapons should not be moved, since re-laying them is difficult. Equipment exchanged may include—

- Machine gun tripods, and other supports for crew-served weapons or equipment.
- Bulky or excess supplies.
- Wire.
- Emplaced sensors and radar sets.
- M8 alarms.

i. **Security and Deception.**

- (1) Communication security measures include using wire as the primary means of communication. Radios are used as little as possible, and the outgoing unit's radios are manned until the relief is completed.
- (2) Deception plans should aid secrecy and surprise. The normal patterns of activity must be maintained by the relieved unit. The relieving unit must conform to this pattern until the relief is completed.

j. **Exchange of Liaison Personnel.** Well before the operation, plans and liaison personnel are exchanged between the relieved and relieving unit. Liaison personnel are exchanged down to company level. Those from the outgoing unit remain with the incoming unit until it is familiar with the situation.

k. **Reconnaissance and Surveillance.** Normal patrols and radar activity are continued. Surveillance teams and radar equipment of the outgoing unit remain on position until the relief is completed. If time is available and the situation permits, the company commanders, scout and mortar platoon leaders conduct a reconnaissance before the relief. Reconnaissance should be conducted during both daylight and darkness, as the incoming unit must know the location of individual and vehicle positions, weapons, communication centers, command posts, aid stations, and all other essential facilities. This reconnaissance should also include all routes for vehicle and foot traffic, the specific location of assembly areas, and locations for service support units. Reconnaissance parties in the forward areas should be small. Vehicles and aircraft used for the reconnaissance should be furnished by the unit being relieved.

1. **Relief Order.** When planning and coordination are complete, the TF commander then issues his order. To reduce confusion and maintain secrecy, the relief order should, as a minimum, include—
 - Time at which responsibility for the sector, BP, or zone is effective.
 - Fire support plan.
 - OPSEC considerations.
 - Deception plans.
 - Time, method, and sequence of relief.
 - Routes and critical control measures.
 - Concept of subsequent mission.
 - Plans for additional positions — changes to present concept.
 - Contingency plans.
 - Location and transfer of responsibility for obstacles.
 - Transfer of ammunition, wire lines, POL, and materiel to incoming unit.

Section IV. BREAKOUT FROM ENCIRCLEMENT

A breakout is an offensive operation conducted by an encircled force. A force is considered encircled when all ground routes of evacuation and reinforcement are cut off by the enemy.

5-12. PURPOSE

- a. A breakout from encirclement is conducted to allow the encircled force to regain freedom of movement or contact with friendly units. Encirclement does not imply that the battalion task force is surrounded by enemy forces in strength. Threat doctrine stresses momentum and bypassing of forces that cannot be quickly reduced. An enemy force may be able to influence the task force's subsequent operations while occupying only scattered positions and may not be aware of the task force location or its strength and composition. The task force can take advantage of this by attacking to break out before the enemy is able to take advantage of the situation.

- b. To be successful in breakout from encirclement, a battalion task force must—
- Deceive the enemy as to the composition, strength, and intentions of the task force.
 - Conduct reconnaissance, then concentrate sufficient combat power at an enemy weak point.
 - Provide security to the flanks and rear of the task force as it moves out of the encircled area.

5-13. PLANNING CONSIDERATIONS

The following special considerations must be weighed in planning a breakout.

- a. **Time of Attack.** Attacking at night or during other conditions of limited visibility is advantageous; however, if waiting for limited visibility risks the destruction of the battalion task force, the attack is executed as soon as possible.
- b. **Location of Attack.** The battalion attacks the enemy's weakest point. Against scattered resistance, it attacks through gaps between enemy units. If the enemy is more concentrated, a penetration may be necessary.
- c. **Speed of Execution.** Breakout operations depend largely on speed of execution. Once the breakthrough is achieved, elements move rapidly out of the encircled area, maintaining the momentum of the attack to link with friendly units.
- d. **Security.**
 - (1) As soon as the task force commander determines that his unit has been encircled, he moves his mortars, combat trains, and main CP toward the center of the area to ensure their survival. Additionally, he may have to redeploy some of the maneuver companies to provide all-round security.
 - (2) Since the battalion task force concentrates the bulk of its forces to break through enemy resistance, its rear and flanks are vulnerable. A rear guard is organized to protect those areas. A feint by the rear guard may deceive the enemy as to the intentions of the task force.
- e. **Evacuation of Wounded.** Wounded soldiers are not left behind. Evacuation of severely wounded by air may be done once the breakout is completed. Less severely wounded soldiers can be evacuated in conjunction with emergency resupply.

f. Destruction of Equipment and Supplies. Equipment and supplies should be carried out of the encircled area. Some usable equipment and supplies may have to be abandoned in order to execute breakout operations quickly. This materiel must be destroyed or disabled.

g. Combat Support. The battalion task force uses suppressive fire to support movement.

h. Organization.

- (1) Regardless of previous command relationships, all elements encircled become attached to the senior tactical commander. The battalion task force is then organized into four elements for breakout operations: rupture force, reserve force, main body, and rear guard. If possible, the task organization of the battalion should complement both the breakout and subsequent attack or linkup (see Figure 5-10).

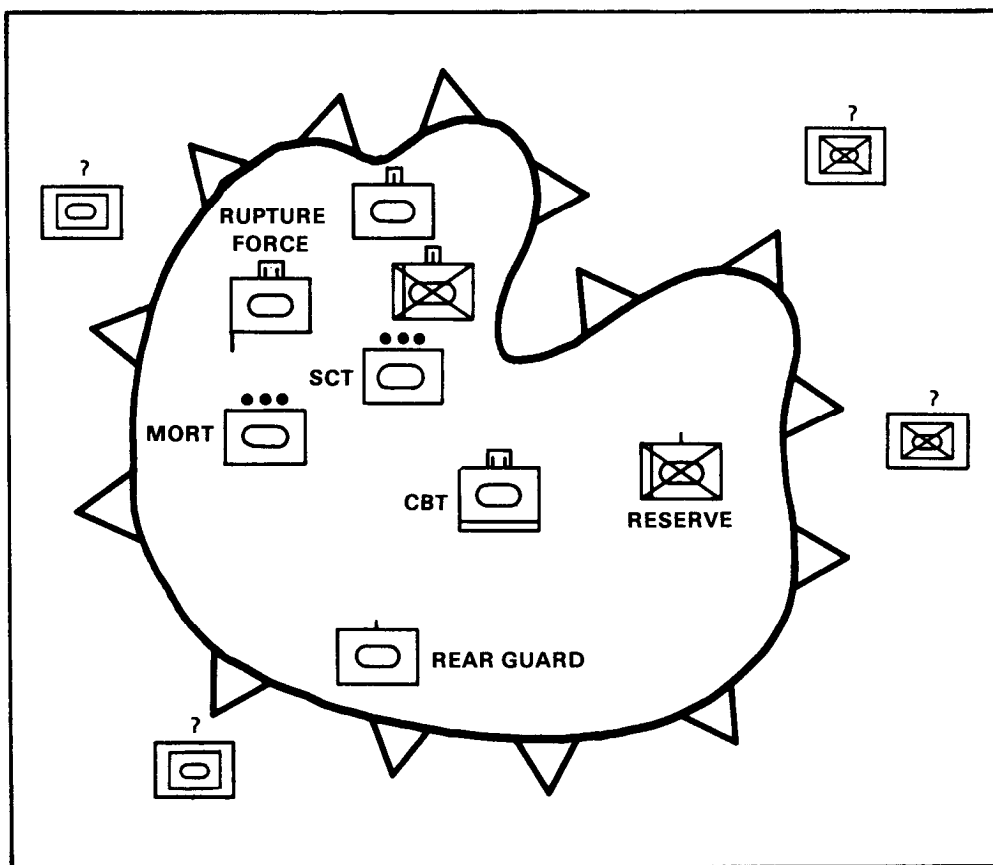

Figure 5-10. Organization for a breakout.

- (a) A rupture force penetrates enemy positions and opens a gap for the remainder of the battalion task force to pass through. Once it has opened a gap, the rupture force holds the shoulders until the main body has passed through. Then it either joins the rear guard or becomes the rear guard, depending on the situation. The rupture force should be organized with the necessary combat power to accomplish the initial rupture of the enemy forces.
 - (b) A reserve force follows and assists the rupture force. The reserve force normally passes through the rupture force, maintaining the momentum of the breakout operation. In determining the composition of the reserve force, the commander decides how much combat power is needed to make the penetration and how much is required to maintain momentum once the operation has started. Once the reserve passes through the rupture force, it usually leads the task force in a subsequent movement to contact.
 - (c) The main body consists of the command group, main CP, and CS and CSS elements. CS elements are task-organized to support the attack. CSS elements move as a single group within the main body. Positive command and control of this element by the S4 combat trains CP precludes unnecessary delay in the task force movement.
 - (d) A rear guard protects the rear of the battalion task force as it moves out of the encircled area. The rear guard must be strong enough to delay or disrupt an enemy attack. It is normally a company team, or a reinforced company. The battalion task force heavy mortar platoon is usually attached to the rear guard.
- (2) The scout platoon may be employed to assist the reserve after its transition to the advance guard. The scouts can conduct forward reconnaissance or screen to the flanks of the advance guard. They may also be placed under OPCON of the rear guard to screen or to maintain contact with the enemy.
 - (3) Since the task force will be required to fight in numerous directions during the breakout, control of task force subordinate elements must be clearly defined. Command of the rupture, reserve, rear guard, CS, and CSS elements is assigned to maintain the momentum of the attack, even if communications within the task force are lost or degraded. The tactical CP is positioned to command and control the rupture operation initially.

- i. **Other Preparations for the Attack.** After the task force commander has completed his estimate, he issues orders and initiates the attack. The rupture force moves to its attack position. The rear guard assumes the defensive responsibility and remains in position to protect the task force rear area and deceive the enemy as to the rupture force's intentions. Control measures for the operation are limited to objectives for the rupture force, an axis of advance, and checkpoints.

5-14. CONDUCT OF THE BREAKOUT

The following scenario is used to illustrate the conduct of the breakout.

At the designated time of attack, the rupture force conducts a deliberate attack to seize its initial objective and hold the shoulders of the penetration (see Figure 5-11, page 38). Once the penetration is made, the reserve force assumes the lead as the task force either continues a deliberate attack or begins a movement to contact. The primary effort of the task force is to make the initial penetration, then to maintain the momentum of the attack. The main body follows the reserve force through the penetration. Initially, priority of fire support goes to the rupture force(s).

The rupture force attacks clearly defined objectives and destroys enemy encountered en route, consolidates and reorganizes their objectives, then establishes hasty defensive positions to widen and secure the shoulders of the penetration.

With the rupture completed and the shoulders secured, the reserve force passes through the penetration and attacks another clearly defined objective or conducts a movement to contact. It is critical for the majority of the battalion task force to leave the encircled area as rapidly as possible.

The rear guard delays to the rupture force's location, then defends with the rupture force until the main body has cleared the penetration. The rupture force then follows the main body while the rear guard continues to delay.

The rupture force defends as long as possible to allow the rear guard to establish hasty defensive positions. On order, the rupture force moves, using the fastest movement technique the situation allows, to join the main body.

Once the breakout is completed, the battalion task force continues its attack to link up with friendly units. The task force may have to conduct hasty attacks or bypass enemy resistance as it fights its way toward friendly forces.

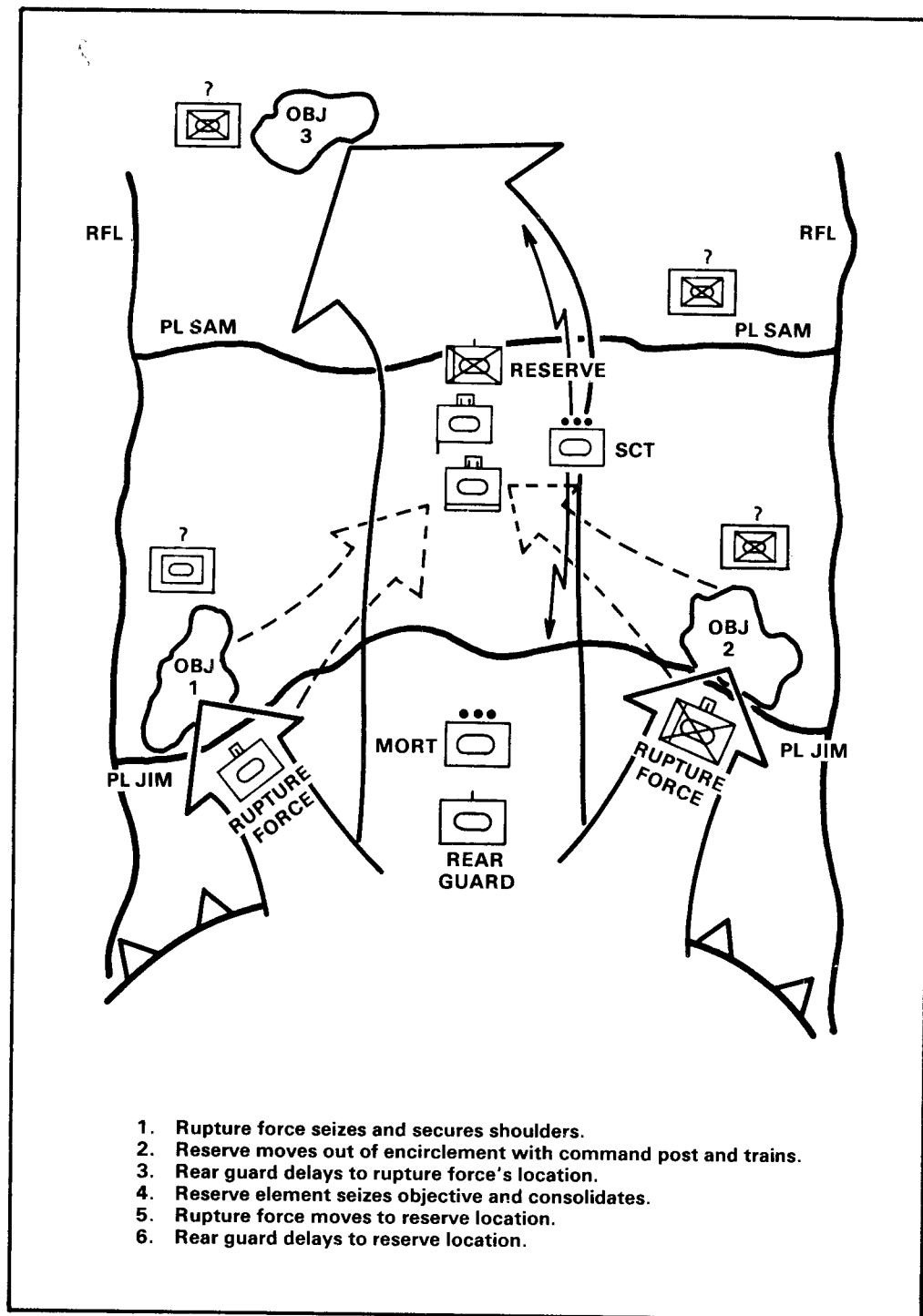

Figure 5-11. Conduct of a breakout.

Section V. LINKUP

A linkup is the meeting of two or more friendly ground forces that have been separated by the enemy.

5-15. PURPOSE

The battalion task force may participate as part of a larger force, or it may conduct a linkup with its own resources. Linkup is conducted to relieve or join a friendly force, or to encircle an enemy force.

5-16. PLANNING CONSIDERATIONS

- a. **Command Relationships.** The headquarters directing the linkup must establish command relationships between forces and the responsibilities of each force during the operation.
- b. **Liaison and Responsibilities.** When possible, the commanders of the units involved establish liaison. If conditions permit, the commander and liaison teams meet face-to-face before the operation begins. If the enemy is between the forces conducting a linkup, this liaison may not occur and coordination is then accomplished by radio. During the operation, the two units attempt to maintain continuous radio contact with each other or the higher headquarters. As a minimum, the units exchange the following information:
 - Enemy and friendly situations.
 - Locations and types of obstacles (existing and reinforcing).
 - Fire support plan.
 - Air defense control measures.
 - Recognition signals.
- c. **Communications.** The headquarters directing the linkup is responsible for ensuring that SOI and recognition signals are compatible between the two forces. If the linking units do not have the same CEOI, the higher headquarters directs one unit to change — normally the unit not in contact. If the units involved in the operation are neither under OPCON nor attached, they maintain their parent command nets; however, recognition signals must be exchanged.
- d. **Coordination of Schemes of Maneuver.** All elements in a linkup carefully coordinate their operations to minimize the risk of fratricide. This coordination continues throughout the

operation and increases as the units approach the linkup points. Control measures used are as follows.

- (1) **Zones of attack or axes of advance.** If one or more of the forces are moving, their direction and objective are controlled by the higher headquarters.
 - (2) **Phase lines.** Movement is controlled by a higher headquarters through the use of phase lines.
 - (3) **Restrictive fire lines (RFLs).** These lines are used to prevent friendly forces from engaging one another with indirect fires. One technique is to make the phase lines on-order RFLs. As the unit crosses a phase line, the next phase line becomes the RFL.
 - (4) **Coordinated fire line (CFL).** This line is used in linkup operations to allow direct fire engagement of targets outside the areas of both units.
 - (5) **Checkpoints.** Checkpoints are used to control movement and designate overwatch positions.
 - (6) **Linkup and alternate linkup points.** The linkup point is a designated location where two forces meet and coordinate operations. The point must be easily identifiable on the ground, and recognition signals must be planned. Alternative linkup points are established in the event that enemy action precludes linkup at the primary point.
- e. **Actions Following the Linkup.** If possible, subsequent operations should be coordinated before the linkup operation and modified, if necessary, when the linkup occurs. The two commanders should collocate near the linkup point, or at a prearranged location, to confirm or coordinate their subsequent operations.

5-17. CONDUCT OF THE LINKUP

The following examples illustrate two types of linkup operations.

Example 1: DOUBLE ENVIRONMENT.

In the first example (see Figure 5-12), two battalion task forces are advancing on separate axes to encircle an enemy force by linking up to the rear of that force. The task forces have coordinated their actions, have maintained radio communications and have exchanged liaison officers. The control measures included on the operation overlays were exchanged.

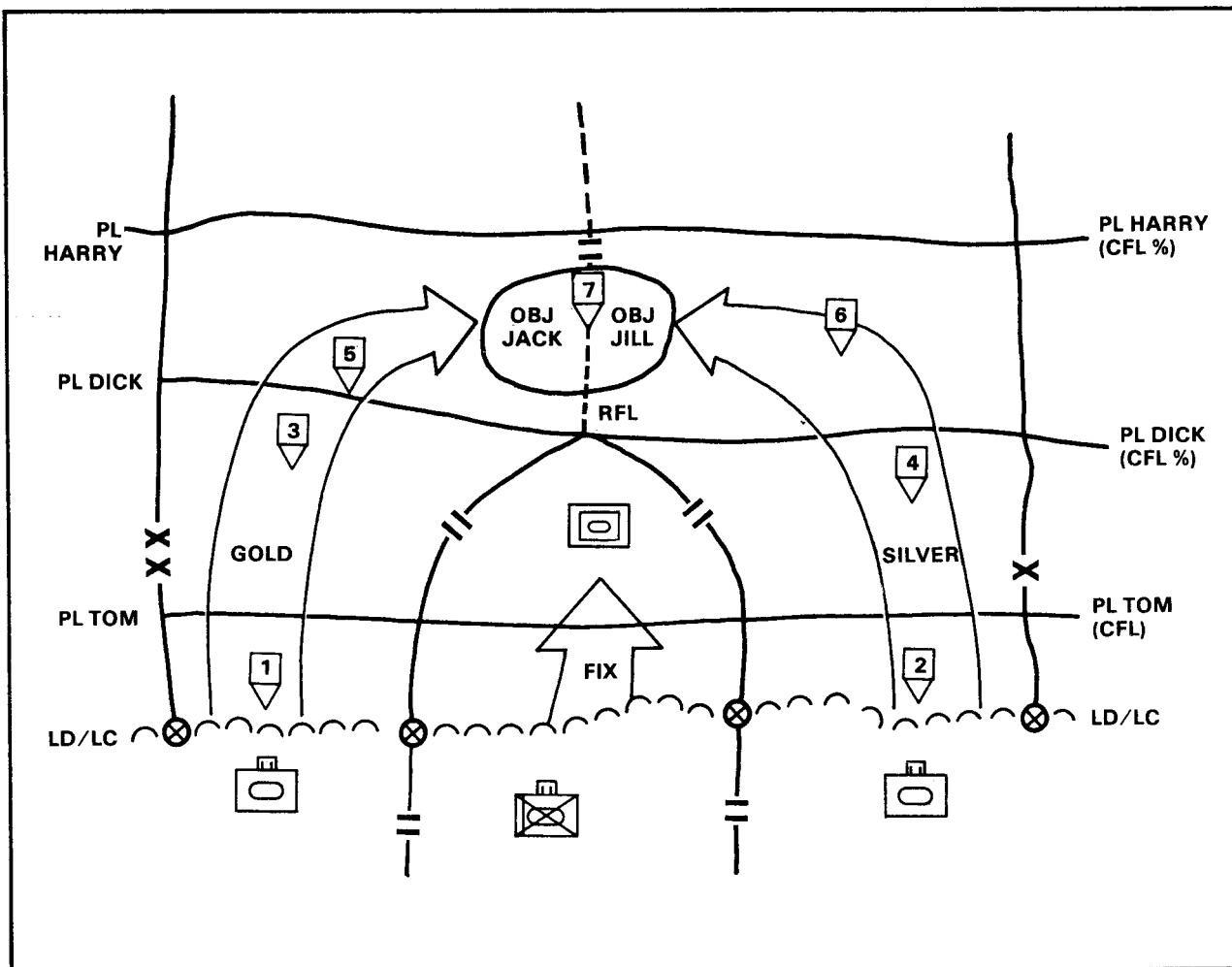

Figure 5-12. Double envelopment.

The two task forces proceed as in a normal attack with the coordination of the two attacks accomplished by brigade. Each task force main CP monitors the progress of the other task force in the operation. The commander is directing the fight forward. As the task forces cross PL DICK and come into direct fire range of one another, both task forces display recognition signs and the two commanders establish direct communications.

The intent of the higher commander is to encircle and reduce the enemy force. Therefore, the task forces move into position after linkup and prevent the enemy from breaking out of the encirclement. The task forces should also ensure that they are secure from enemy forces attempting to link up with the encircled force.

Example 2: LINKUP WITH AN ENCIRCLED FORCE

In the second example (see Figure 5-13), the brigade is conducting an air assault followed by a linkup with an armored task force. In this operation, the CFL and RFL will shift as the operation progresses. Ideally, ground and air attacks commence simultaneously. As in the previous example, each unit main CP monitors the progress of the other battalion while the commander directs the battle. The CFL and RFL are shifted as the operation progresses. As the armored task force nears the linkup point, direct and indirect fires are more tightly controlled to preclude friendly casualties. Upon linkup, the tactical CPs of the units meet face-to-face for coordination of subsequent operations.

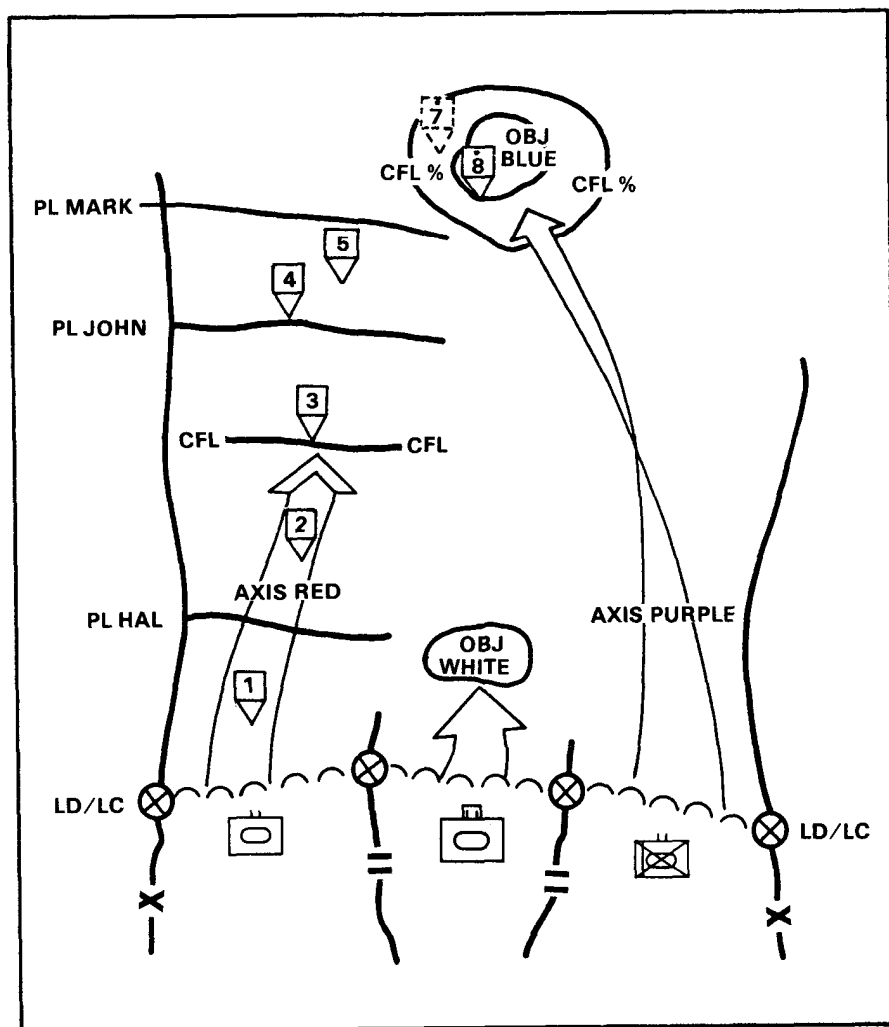

Figure 5-13. Linkup.

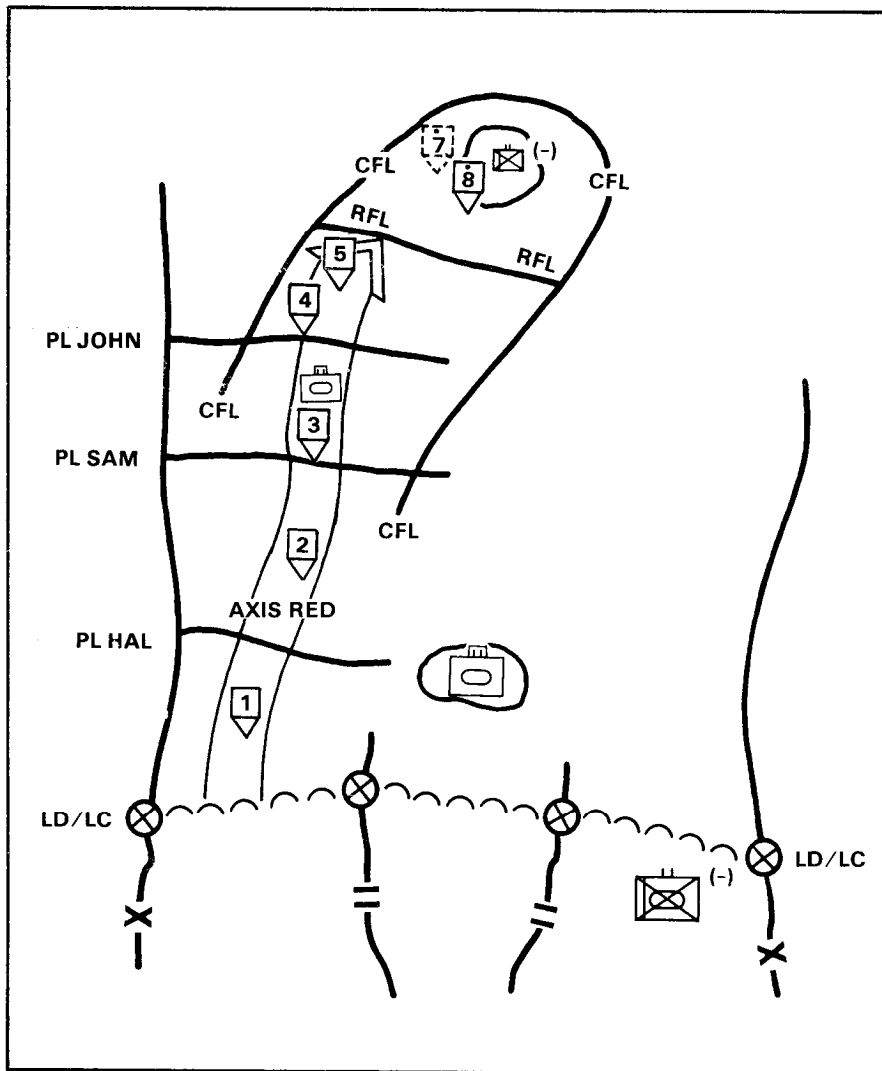

Figure 5-13. Linkup (continued).

Section VI. HASTY WATER CROSSINGS

The three types of water crossings conducted by a battalion task force are hasty, deliberate, and retrograde. Hasty water crossings are normally used by the battalion task force to maintain momentum. A hasty water crossing is a decentralized operation to cross an inland body of water such as a canal, lake, or river. These operations include crossings by tactical bridging or by swimming or fording vehicles.

The battalion normally participates in a deliberate or retrograde river crossing as a part of a larger force. (For a detailed explanation of deliberate and retrograde water crossings, see FM 90-13 and FM 71-3.)

5-18. PURPOSE

Hasty water crossings are conducted to maintain the momentum of an operation. The approach to the water obstacle is made rapidly on a broad front whenever possible. Hasty crossings using captured bridges or fords are the product of rapid offensive action.

5-19. CHARACTERISTICS

- a. Although the crossing is termed *hasty*, detailed planning ensures that fire support and crossing means are available when the force arrives at the water obstacle. Hasty crossings are feasible when the site is lightly defended, when crossing means are readily available, and when mechanized infantry and fire support are sufficient.
- b. Crossings are not entirely dependent on the seizure of bridges or fords. Normally, mechanized infantry units cross first to establish a bridgehead on the far bank to protect the crossing of the remainder of the command.
- c. Hasty water crossings are characterized by—
 - Speed, surprise, and minimum loss of momentum.
 - Decentralized operations with organic, existing, or expedient resources.
 - Weak (or no) enemy defenses on both banks.
 - Minimum concentration of forces.
 - Quick continuation of the operation.

5-20. PLANNING CONSIDERATIONS

- a. **Command and Control.** Control of elements in and around the site is accomplished by the battalion XO.
- b. **Crossing Assets.** All available assets are used to cross the most troops and items of equipment in the shortest possible time. Vehicles that have a swimming capability are used to expedite

the crossing. The main battle tank (M1), without preparation, has a 1.2-meter fording capability. In addition, supporting engineers may furnish or construct such additional crossing means as AVLBs, rafts, bridges, and assault boats. Available assault helicopter assets can also move troops, supplies, and equipment across the river.

c. **Timing of the Crossing.** The decision whether to cross in daylight or in darkness depends on the need for concealment, state of training of troops, nature of the terrain, characteristics of the water obstacle (and any obstacles on the far bank), enemy disposition and capabilities, and the need for speed. Specific actions that must be timed carefully to ensure success of the crossing are—

- Movement of crossing troops into attack positions.
- Movement of reserve elements into assembly areas.
- Use of smoke.
- Feints, demonstrations, and other deception measures.
- Suppressive fires.
- Artificial illumination.

d. **Selection of Crossing Sites.**

- (1) Unless a repairable or intact bridge is seized, crossing areas must be reconnoitered and selected. During the advance, it is usually not feasible to determine the exact location of each crossing site. Nevertheless, during planning stages, information pertinent to the general crossing area is collected and analyzed to determine likely crossing sites and to guide further reconnaissance.
- (2) In the selection of crossing fronts, areas, and sites, both technical and tactical requirements must be considered and evaluated. The crossing should be planned on a wide front with several attacks at separated localities to deny the defender the capability of massing his fires or his counter-attack on more than one of these localities. The following desirable site characteristics are sought in a river crossing (and generally apply to any water-crossing operation):
 - Banks lightly held or undefended by the enemy.
 - Ready access to a good avenue of approach to objectives on the far bank.
 - Dominating terrain on the near bank for artillery observation and direct fire.

- A bend in the water toward the attacker (salient) of such size and configuration that it favors the concentration of the crossing (assaulting) force and denies the enemy effective direct fire on the crossing site.
- Covered approaches to the river.
- Existing or easily constructed access routes from roads to the site.
- Unobstructed water area.
- Suitable above and below water level banks requiring minimum preparation for entry and exit of amphibious and fording vehicles.
- A stretch of river avoiding areas where the current is swift. Moderate current is less than 1.5 meters per second.
- Bed composition and water depth that will permit fording.
- Swim sites—
 - where the speed of stream current is less than the swimming speed of the vehicle.
 - with gentle gradient and a firm bottom for entering and leaving the water (ford bottoms may be improved with AVLBS).
- Raft sites —
 - with a gentle current near each bank.
 - with a streambed free from ledges, rocks, shoals, islands, sandbars, and other obstructions that would prevent or hinder crossings.
 - with banks not so high or steep as to require excessive grading for approach. The water close to the bank should be deep enough to float a loaded raft without grounding.
 - with cover and concealment on both banks for vehicles or troops waiting to be loaded or unloaded.
- Floating bridge —
 - with firm stream banks.
 - with moderate current generally parallel to the banks.

e. **Reconnaissance of Crossing Sites.** Elements having an opportunity to physically reconnoiter the crossing site should be augmented by engineers. Engineers provide technical expertise on the characteristics of the crossing site and reduction of any

obstacles the enemy may employ. The purpose of reconnaissance is to locate, mark, and report suitable crossing sites. This includes determining the amount and type of enemy resistance; marking approaches and crossing sites with flags, engineer tape, and ropes; and inspecting captured bridges and abutments. Most important to the task force commander is the result of on-site physical reconnaissance by scouts, mechanized infantry, and engineers with respect to entrances and exits, stream velocities, streambed conditions, and depths for vehicle swimming and fording operations. Reconnaissance may be conducted under enemy observation and fire. Up-to-date aerial reconnaissance and photography, radar observations, and infrared imagery provide task force commanders with information on shorelines, crossing conditions, approaches, streambed, approximate velocity of current and stream depth, possible shallow fording sites and submerged obstacles, and favorable bank gradients.

5-21. CONDUCT OF HASTY WATER CROSSINGS

During the movement to the water obstacle, the task force commander deploys his force for the anticipated crossing. He task-organizes to ensure that sufficient combat and engineer assets are at the crossing site to eliminate enemy resistance and to maintain momentum. He advances as rapidly as possible to seize bridges intact before the enemy can destroy them. The lead company clears the near bank of defending or delaying enemy elements and sets up overwatch. Reconnaissance personnel and engineers immediately reconnoiter the crossing area. An air assault may be used to neutralize enemy defenses on the far bank. Supporting engineers with river crossing equipment are positioned well forward in the formation so they can rapidly assist in crossings or bridge repair. Often, a partly demolished bridge can be quickly made usable by supporting engineers using AVLBs to overbridge weakened or demolished spans.

a. Engineers.

- (1) Engineers closely follow the lead elements and remove or neutralize any demolitions or mines on bridges, on approaches, or at the crossing sites. Task force personnel, augmented by engineers when available, conduct the site reconnaissance. Engineers support the crossing operation by—
 - Improving entrances and exits.
 - Removing obstacles at entrances and exits.
 - Conducting or assisting in underwater reconnaissance.

- Providing assault boats, rafts, ferries, and bridging.
- Improving ford sites (AVLBs can be used to protect the bottom of ford sites).

(2) Engineer crossing equipment and capabilities.

- (a) **Armored vehicle launched bridge (AVLB).** The AVLB lays a 60-foot class 60 bridge over 57-foot gaps in 4 minutes.
- (b) **Mobile assault bridge (MAB).** It can be linked rapidly (150 meters per hour) to form bridges or rafts of various sizes and capacities. The maximum single vehicle load for the MAB is class 64.
- (c) **Ribbon bridge (RB).** With the aid of boats, bridge bays form class 70 bridges or rafts at the rate of 20 or more feet per minute.
- (d) **Medium girder bridge (MGB).** One MGB set allows for the construction of a 102-foot class 60 bridge which spans 95-foot gaps. With a reinforcement kit and two sets of MGB, a 160-foot span (MLC 60) can be constructed. The MGB can withstand class 70 loads.

b. **Preparation.** Armored vehicles may be required to stop briefly in a covered and concealed location so that they can be prepared for the crossing. Additionally, the entry site may require improvement.

c. **Movement.** The movement to the water obstacle is timed so that the initial crossing unit does not pause at the crossing site, but moves directly into the water. The time between the approach to the water obstacle and the crossing must be held to a minimum. Once started, the crossing is completed as rapidly as possible.

d. **Formation and Priority of Crossing.**

- (1) The mission, number of entrances and exits, and the number of vehicles to cross are the most important considerations in determining the formation and priority for crossings. When the water is shallow and free of obstacles, and when the banks permit, tanks ford in a platoon column formation.
- (2) Amphibious vehicles should cross in waves, preferably formed by platoon. With no current, each wave should cross in line formation. Echelon formation should be used where there is a current. In an echelon formation, the vehicles move out in successive order, starting with the vehicle farthest downstream and proceeding to the vehicle farthest upstream. This will ensure that upstream vehicles do not drift into

downstream vehicles. Amphibious vehicles should cross downstream from tanks using ford sites.

- (3) If no bridges or ford sites are available for tanks, then BFVs assault to the far bank while the tanks provide direct fire support. BFVs and dismounted troops seize limited objectives, conduct reconnaissance, and improve exits. Additional troops and equipment may be rafted to secure and expand the bridgehead. When available, air cavalry and air assault units can be used to assist in securing and expanding the bridgehead and aviation units for ferrying troops and equipment. When the far shore is clear of enemy, bridges or rafts are erected and the remaining troops and vehicles cross. Priority is given to tanks and air defense weapons.
- (4) Vehicles that have to recross the water obstacle by swimming will require entrances and exits for one-way passage. This will avoid traffic congestion and confusion created by oncoming vehicles at the original crossing sites.
- (5) In an NBC environment, over-concentration of troops in the bridgehead area must be avoided to prevent presenting a lucrative target.

e. **Fire Support.** Maximum fire support is employed against known and suspected enemy positions on the far shore. Smoke (see Figure 5-14, page 50) is often used, particularly on the flanks, to screen the reconnaissance and crossing. When tanks support by direct fire, fire control measures must be well coordinated.

f. **Limited Visibility.**

- (1) These crossings differ from daylight crossings because stringent control and coordination are required to prevent massing of vehicles at entrance and exit sites and to prevent accidents. The amount of natural light and availability of night vision devices and thermal imaging systems must be considered when planning a limited visibility crossing.
- (2) During crossings in limited visibility, entrance and exit sites must be marked by lights or other means that permit detection by the driver or vehicle commander. Reference points on the far shore must be readily identifiable or illuminated to assist in maintaining direction.

g. **Crossings During Cold Weather.**

- (1) Ice thickness may permit crossings of tanks and heavy vehicles; however, a reconnaissance is necessary to determine if the ice will support these vehicles. The banks may require improvement to permit entrance and exit.

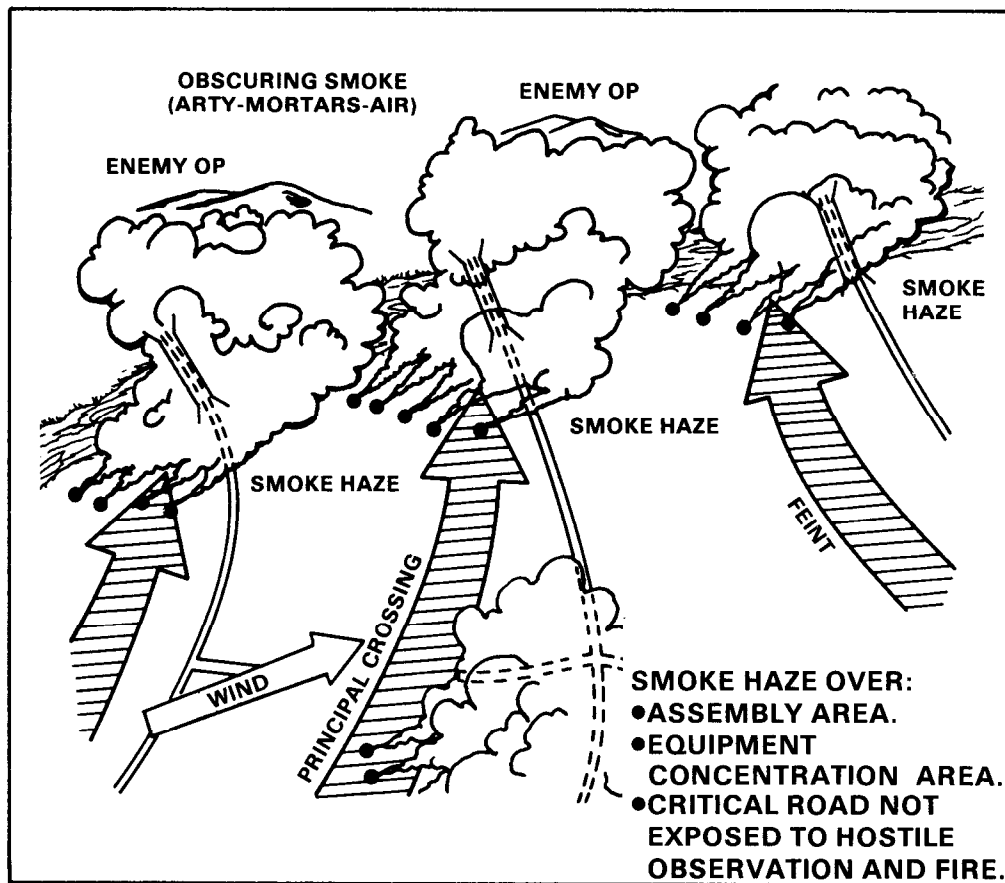

Figure 5-14. Smoke employment during crossing operations.

- (2) When ice conditions do not permit crossing by vehicles and there are no bridges available, clearing the ice may be quicker and less time-consuming than reinforcing it. Dismounted elements cross to the far bank by foot or are air assaulted to secure the area and to reconnoiter and prepare exit sites. Reconnaissance elements on the near bank select and prepare entrances and determine where to place explosives to clear lanes through the ice (fewer explosives are required if placed under the ice). When more than one lane is to be cleared, the distances between lanes must be sufficient to prevent the ice between lanes from drifting and closing other lanes or damaging vehicles. After blasting, M113's can move into the water to clear the lanes of loose and drifting ice; BFVs are not well suited for this task, because of the vulnerability of their water barriers. Amphibious vehicles should not be used to break ice.

- (3) During the crossing, ruts will develop at entrances and exits and may require bulldozing or filling. Consideration must be given to placing engineers in the formation so that they will be available for this task.
- h. **Recovery.** During all water-crossing operations, maintenance personnel and equipment should be near both sides of crossing sites to assist in the recovery of stalled or sunken vehicles.
- i. **Control.** The battalion task force XO (or CSM) assumes the duty of crossing control officer (or NCOIC) after the site has been secured and the attack is being continued on the far bank. This frees the commander to concentrate on the unit's mission. The company team executive officers provide the same function for company teams if required. The S4 controls the crossing of the combat trains, and the HHC company commander controls the crossing of the field trains.
- j. **GSR.** During limited visibility, radar may be used to detect enemy troop activity on the far bank such as withdrawal, reinforcement, or shifting of units.

Section VII. GUARD OPERATIONS

A guard operation is a security operation in which a unit protects a larger unit by maintaining surveillance, providing early warning, destroying enemy reconnaissance elements, and preventing enemy ground observation of and direct fire against the main body.

5-22. PURPOSE

The guard force provides the larger force warning, reaction time, and maneuver space. The guard force delays, destroys, or stops the enemy within its capability. The commander conducting the guard operation must know the intent of the higher force commander and the degree of security required.

5-23. TYPES OF GUARD OPERATIONS

Guard operations can be to the front, rear, or flanks of the main body (see Figure 5-15, page 52). Battalion task forces have the mobility, organization, and equipment needed to perform a guard operation as a part of a brigade or division offensive operation. They may be assisted by air cavalry or attack helicopter units under their operational control.

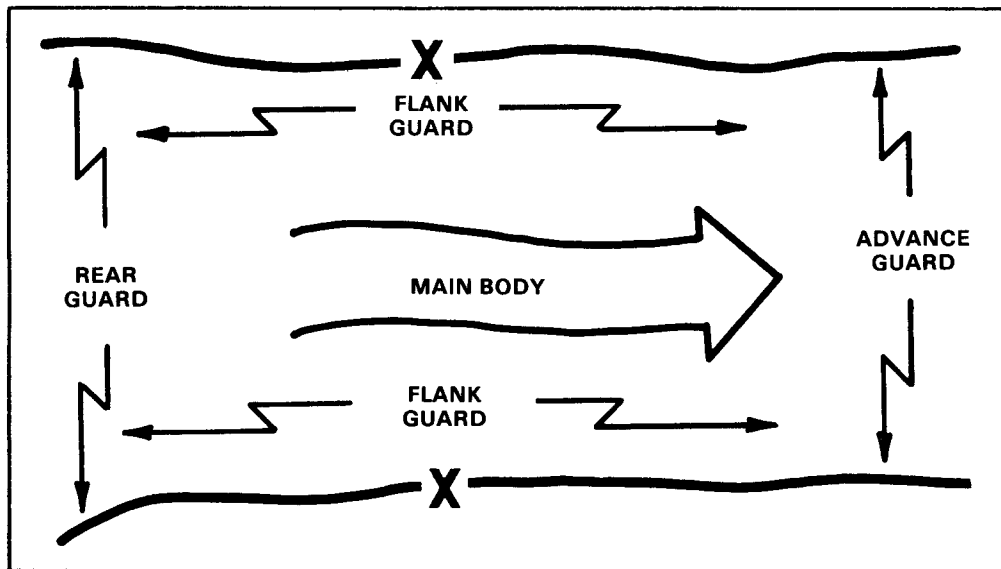

Figure 5-15. Rear, flank, and advance guard operations.

5-24. CONDUCT OF GUARD OPERATIONS

The guard force protects the main body from surprise, direct fire, and premature deployment. The guard is expected to attack, delay, or defend as required to destroy enemy reconnaissance elements and force deployment of the enemy's first echelon. Commanders receiving flank guard missions must clear the area between the main body and its designated positions. The guard force may require additional ground or air assets to accomplish this. A battalion task force conducting an advance guard operation for a moving force must protect the entire front of the moving force. Normally, the battalion task force is augmented (OPCON, attached, or DS) with engineer, air defense, chemical, air cavalry, or attack helicopter forces. Units performing guard missions are normally given priority of fires from designated field artillery units within the main body.

a. Advance Guard.

- (1) A task force conducting an advance guard normally conducts a movement to contact with company teams advancing on axes (see Figure 5-16), in zone (see Figure 5-17, page 54), or, rarely, along directions of attack, depending on the commander's estimate.
- (2) The trail elements of the task force should be at least 3,000 to 4,000 meters forward of the main body lead elements to

allow freedom of maneuver for the main body. The main body commander must establish phase lines to control the movement of the main body and the advance guard. During this operation, advance guard units should remain within main body artillery range.

- (3) The advance guard force attempts to destroy enemy forces through hasty attacks. It may be necessary for the task force to mass at certain locations, destroy the enemy, report, and continue. If enemy resistance is too well prepared and cannot be destroyed, the battalion task force reconnoiters to identify a bypass route for the main body, report the enemy size and location, and (when given permission) fix and bypass the enemy. It is then the responsibility of the following attacking forces to destroy the bypassed enemy. The main body commander may elect not to bypass the enemy, but to conduct a deliberate attack. In this instance, the advance guard keeps the enemy contained and prepares to pass main body elements through to eliminate the enemy.

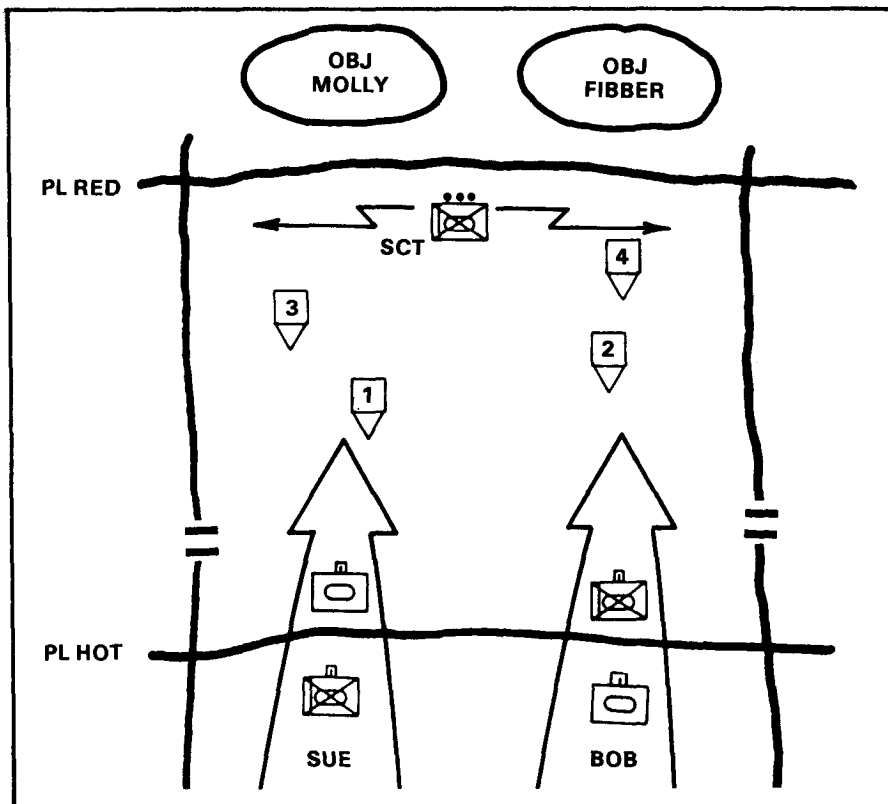

Figure 5-16. Advance guard (company teams advancing on axes).

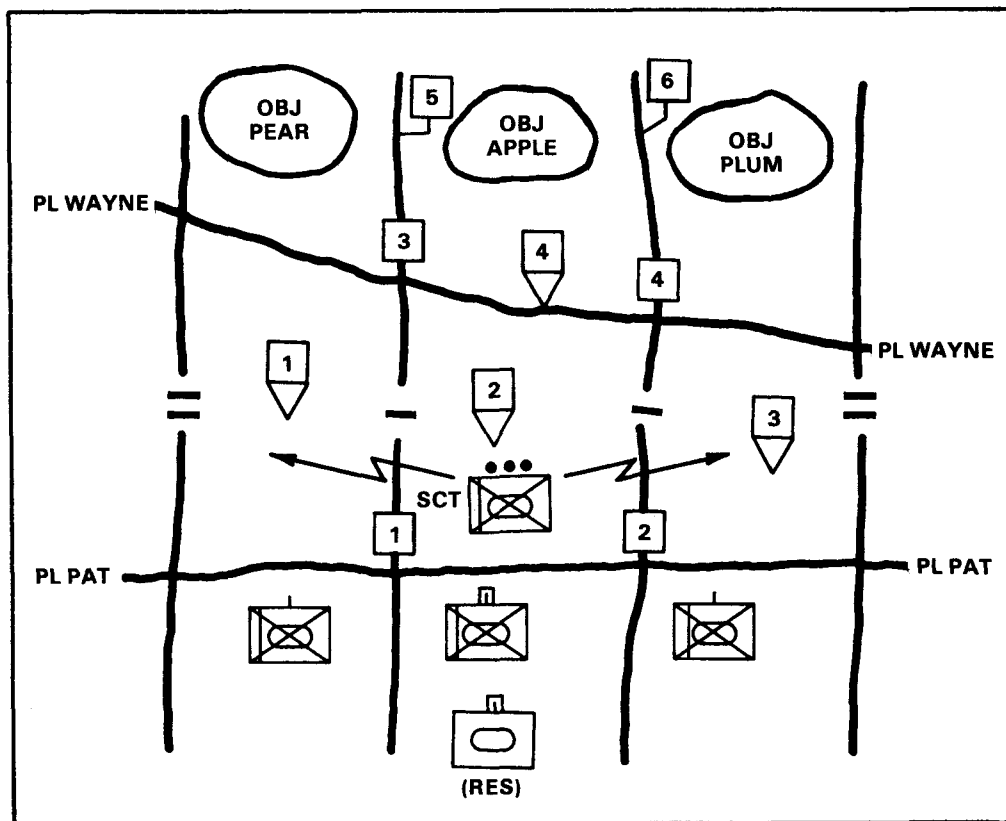

Figure 5-17. Advanced guard (company teams advancing in zone).

b. Flank Guard.

- (1) A battalion task force conducting a flank guard operation must first clear the area between the line of battle positions and the main body. Units attack, if necessary, to establish battle positions and then defend them.
- (2) Normally, the main body commander specifies which units to protect. This responsibility usually extends from the rear of the lead battalion task force in the main body to the rear of the main body, exclusive of the rear guard. It is the flank guard's responsibility to monitor movement of the main body and key his movement accordingly.
- (3) As the main body advances, the flank guard's elements move from battle positions using one or more of three basic methods.
 - (a) **Alternate bounds.** This method (see Figure 5-18) may be used when the protected force is advancing slowly

and strong enemy action is anticipated against the flank guard. In this method, designated elements of the flank guard occupy new positions as required by the movement of the main body. This method is secure but slow.

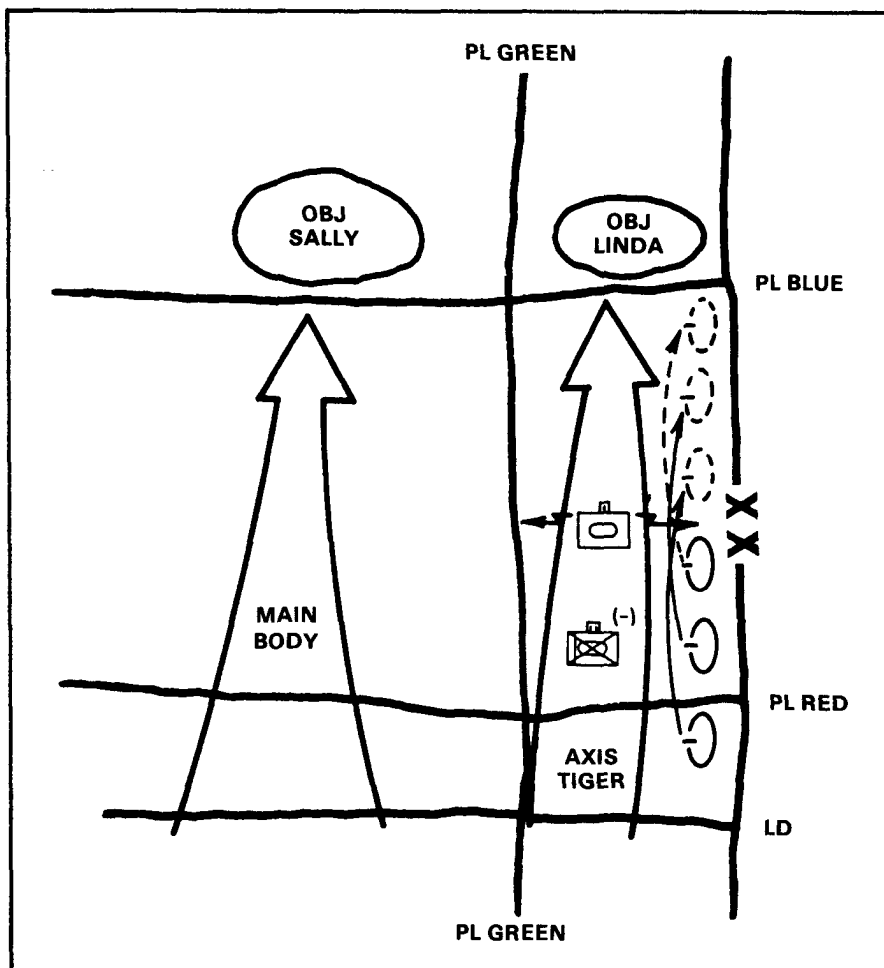

Figure 5-18. Movement by alternate bounds.

- (b) **Successive bounds.** This method (see Figure 5-19, page 5-56) is used when the movement of the main body is characterized by frequent short halts, and enemy action against the flank guard is light. Each company team occupies designated battle positions. When forward movement resumes, company teams move simultaneously, retaining their relative position in the flank guard formation as they move forward to occupy new battle positions.

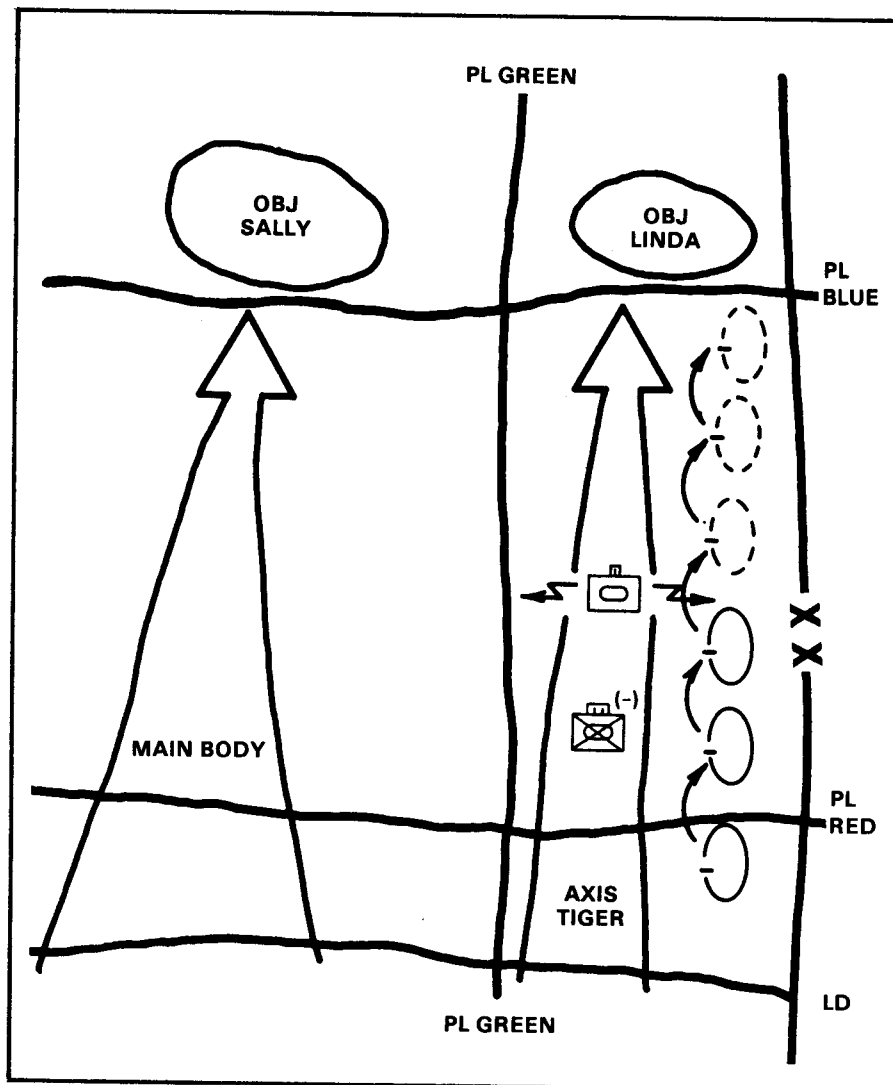

Figure 5-19. Movement by successive bounds.

- (c) **Moving guard.** This method is used when the main body is advancing rapidly at a constant rate and there is no enemy action on the flank (see Figure 5-20). The flank guard uses a column formation and moves without halting, adjusting its rate of advance to the movement of the main body. Air and ground elements from the main body or the flank guard reconnoiter to the flank as the remainder of the flank guard moves along the route of advance. Battle positions are still planned and, if necessary, are occupied.

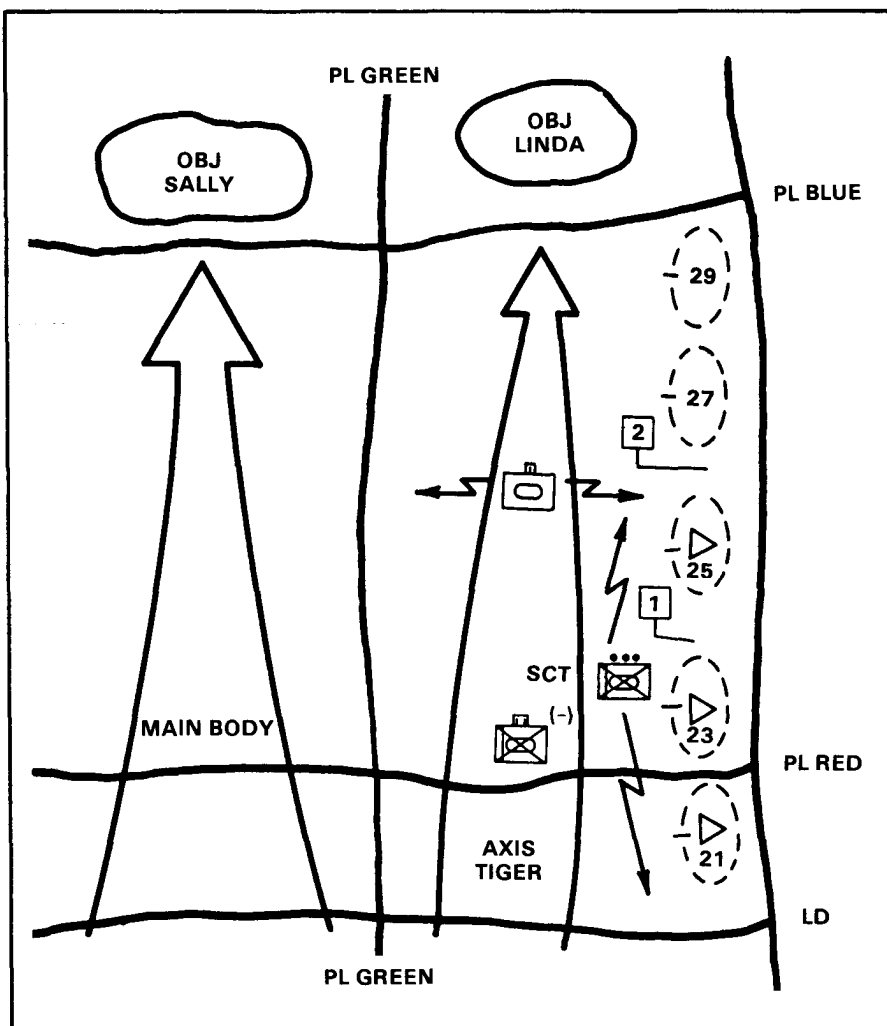

Figure 5-20. Moving guard.

- (4) The main body commander may designate an axis of advance or area of operations for the flank guard. In either event, the flank guard selects a series of prospective company team battle positions along the route of march that dominate likely enemy avenues of approach. The route of march of the flank guard is planned to facilitate rapid occupation of these battle positions if required.
- (5) The leading team maintains contact with the rear of the advance guard battalion task force (of the main body) and screens the area between the main body and the flank guard axis of advance.

- (6) If the task force must defend from more battle positions than it has company teams, the commander must seek relief from the main body commander. The flank guard commander should recommend reinforcing the flank guard with main body forces or relieving the unit of the responsibility for part of the area.
- (7) If the task force faces a strong enemy attack or counterattack, the flank guard commander may have to use a combination of offensive, defensive, and delaying techniques.

c. Rear Guard.

- (1) The rear guard protects the rear of the main body and all CS and CSS elements within the main body. It accomplishes this operation by conducting attacks, a defense, or a delay.
- (2) A battalion task force commander conducting a rear guard operation follows the same axis of advance as the protected force at a distance prescribed by the main body commander. (The prescribed distance is normally within artillery range.) The task force commander establishes company team battle positions (see Figure 5-21) or sectors (see Figure 5-22). With sectors, he designates phase lines and checkpoints to control movement.

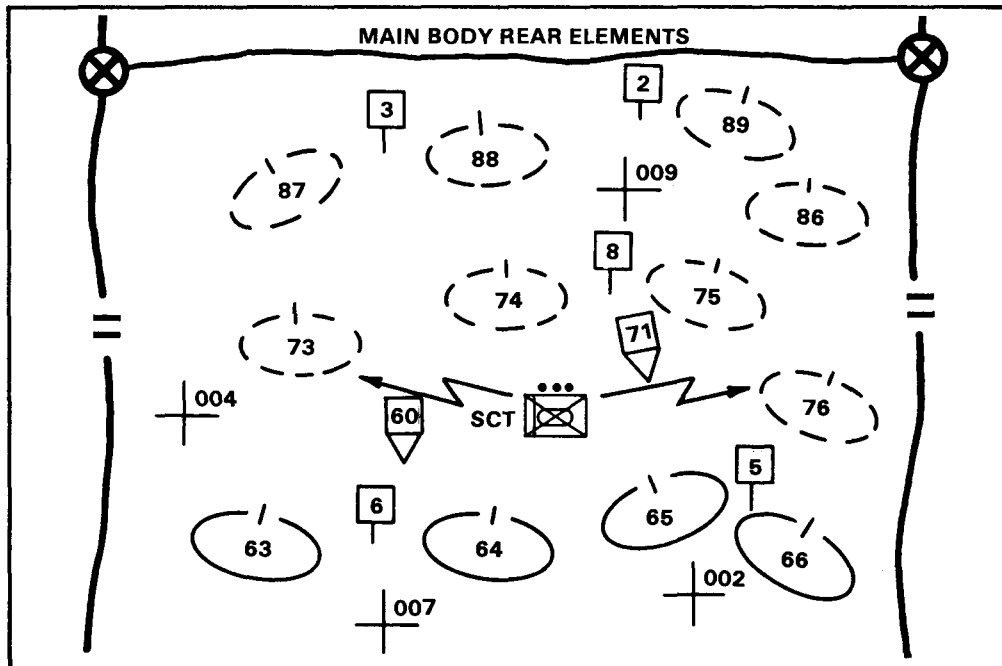

Figure 5-21. Rear guard — battle positions.

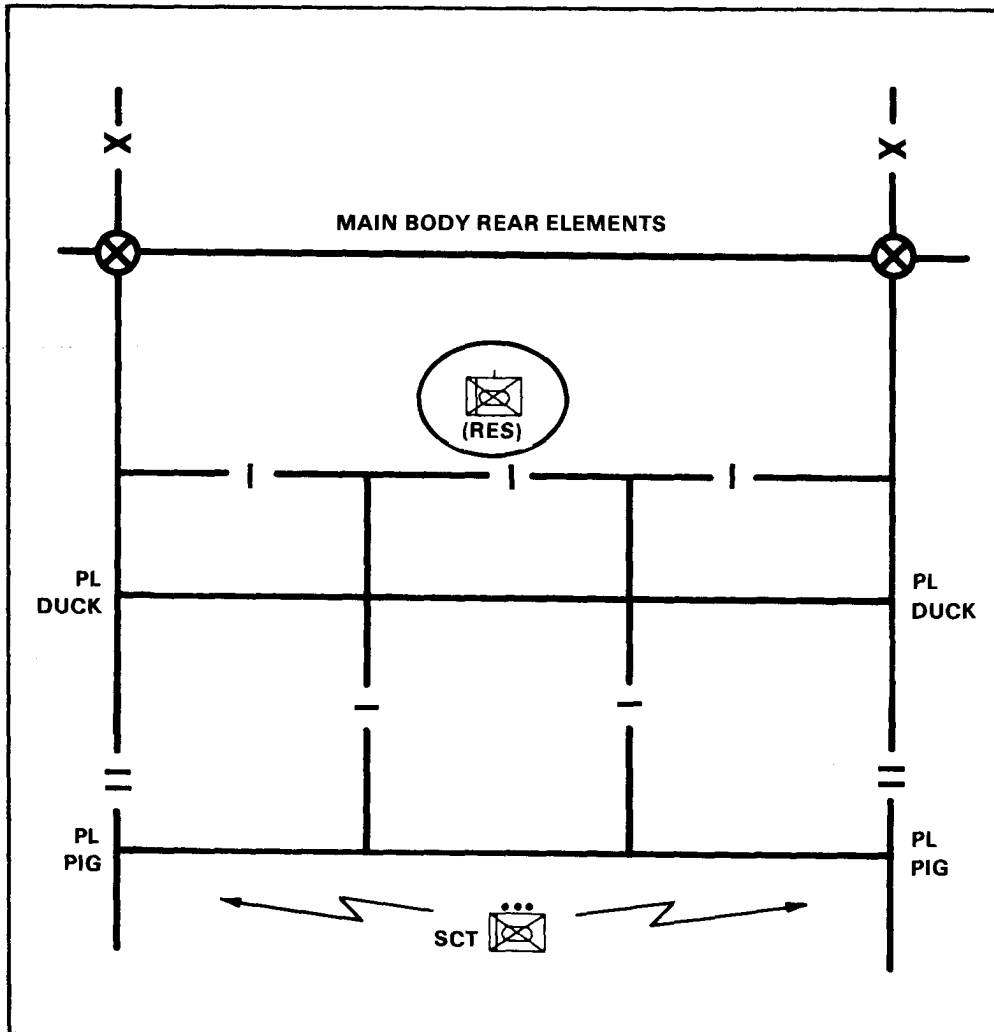

Figure 5-22. Rear guard — delay in sectors.

- (3) Battalion task force scouts are employed to screen between battle positions, to screen forward of battle positions, or to reconnoiter in-depth positions and routes. Additional duties may include liaison with main body rear elements or making contact with flank guard units. The rear guard's responsibility begins at the main body rear boundary and extends as far from this boundary as conditions (METT-T) allow. As a minimum, the farthest elements of the rear guard should beat least 3,000 to 4,000 meters to the rear of the main body rear boundary; the limiting factor on this distance is the range of the main body's supporting artillery.

Section VIII. OBSTACLE REDUCTION

In combat, the battalion commander can expect to be confronted by a variety of existing and artificial obstacles. Obstacles must be rapidly overcome to retain the initiative and maintain momentum. The commander must quickly decide whether to bypass, breach, or force through the obstacle. Forcing through is done only when no other way to overcome the obstacle exists; it results in high losses of personnel and equipment. The urgency of the mission is the deciding factor. In any event, obstacles must not be the focus of attention. They should be planned for and breached or bypassed quickly, almost in stride.

5-25. BYPASSING OBSTACLES

Obstacles are always bypassed when possible. When enemy “firesacks” can be avoided, bypassing an obstacle prevents friendly troops and vehicles from being exposed to enemy direct and indirect fire (see Figure 5-23). Scouts are deployed laterally around an obstacle to reconnoiter the limits of the obstacle, bypass routes, available cover and concealment, enemy locations and weapons, and enemy counterattack routes into the area on the far side of the obstacle and over bypass routes. Overwatch elements must immediately be established to provide protection for the scouts. This must be planned and rehearsed to save time and prevent confusion. Normally, the lead company establishes the overwatch. At the same time, scouts are reconnoitering laterally for bypass routes; and infantry and engineers are reconnoitering the obstacle, since bypass may not be possible. Aviation assets provide assistance in locating bypass routes, overmatching ground elements, and preventing enemy reinforcement or counterattack.

5-26. BREACHING OBSTACLES

Threat defensive doctrine emphasizes employment of obstacles in depth during defensive operations. Obstacles that will normally be encountered are—

- Minefields.
- Log obstacles such as abatis, log cribs, stumps, and posts.
- Tank ditches and craters.
- Wire obstacles.
- Chemical obstacles.

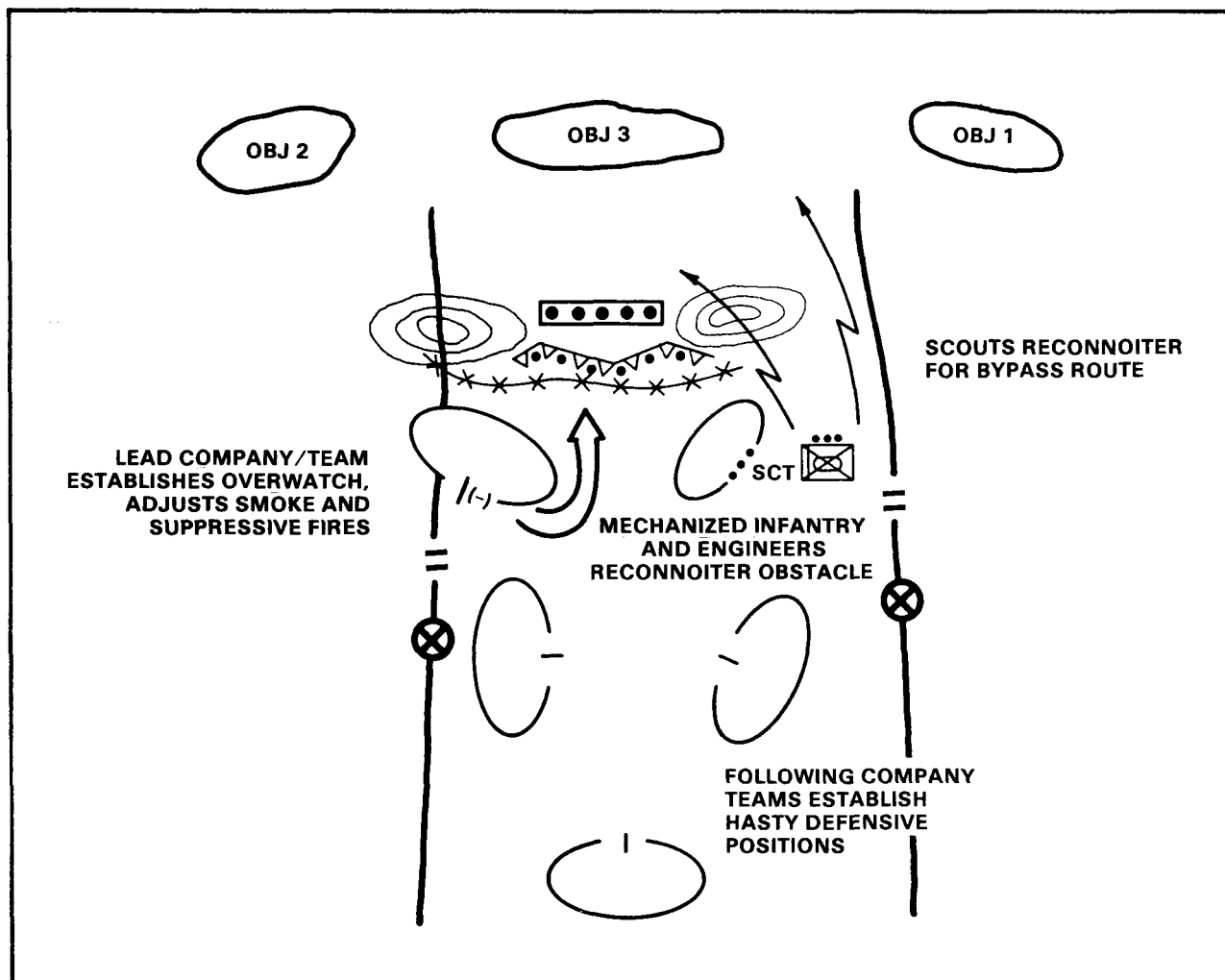

Figure 5-23. Bypassing an obstacle.

a. Methods of Breaching.

- (1) If bypass cannot be done, two methods of breaching may be employed.
 - (a) **Hasty (in-stride) breaching.** Hasty breaching is used when the momentum of the attack must be kept up. It will usually be conducted under fire; therefore, speed is extremely important. Combat engineers are located with the breaching force of the battalion to perform hasty breaches. However, time and distance factors may require hasty breaches by maneuver units without direct engineer participation.

- (b) **Deliberate breaching.** This is done when the hasty breach has failed or speed is not critical and time and additional resources are available. Engineers normally do the breach. Maneuver units provide security, reconnaissance, and overwatch for breaching forces.
- (2) Whether conducting a hasty or deliberate breach, the battalion uses established battle drills, habitual relationships, and SOPs.
- (3) The task force must look beyond the first obstacle belt to locate subsequent obstacle belts. The commander must prevent the battalion from being pinned between obstacle belts.

b. Organization.

- (1) The battalion task force normally organizes into three elements in anticipation of conducting breaching penetrations.
 - (a) **Support force.** The support force is the lead company/team(s). It provides close, continuous overmatching fires to support the breaching force initially, and then the assault force. As required, some of the support force may have their fires directly controlled by the assault force to ensure coordination of fires.
 - (b) **Breaching force.** The breaching force is the second element of the TF formation. It creates lanes in the enemy's obstacle system and forward defenses to allow passage of the assault force through the obstacle. The breaching force may be required to widen the lanes later to allow continuation of the operation. The breaching force is normally task organized with engineers and infantry. They are overmatched by the support forces.
 - (c) **Assault force.** The mission of the assault force is to attack through the breach and destroy the enemy protecting the obstacle (see Figure 5-24).
- (2) Detection of the obstacle is the most critical task. Various methods of detection are available, including air and ground reconnaissance. Normally, the scouts or lead unit in the attack will detect the obstacle first. Engineers should be positioned with the lead element to quickly assess the obstacle. The scouts may be augmented by one or more engineers for the same purpose. When possible, nighttime prebreaches are accomplished. If a unit runs into an obstacle, it must accomplish these four critical tasks:

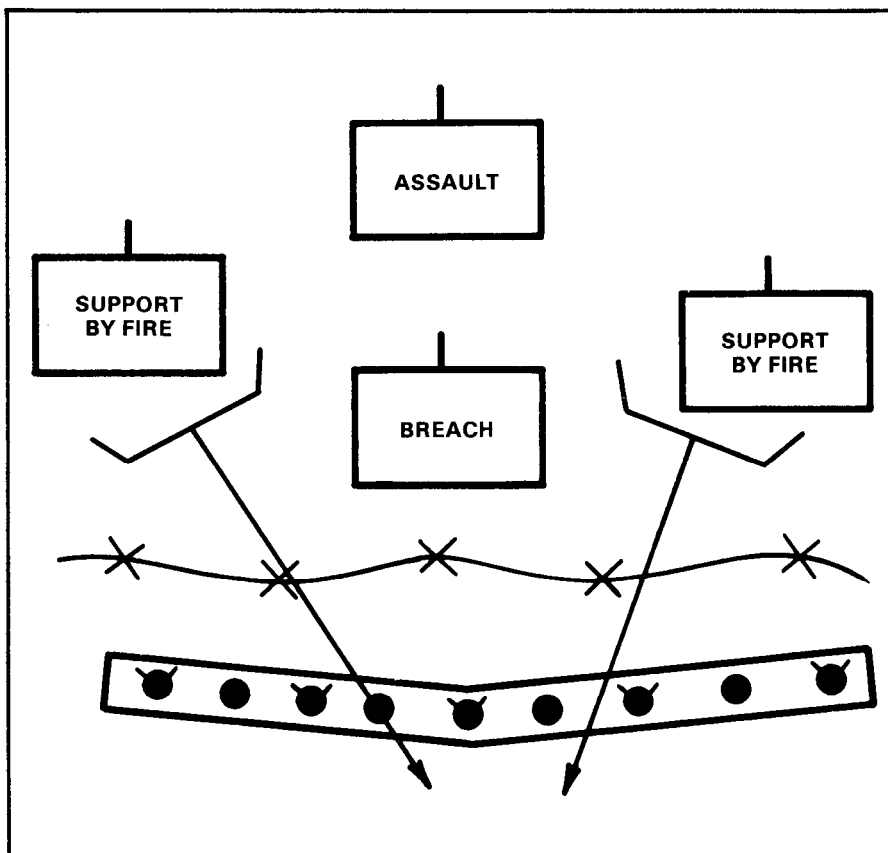

Figure 5-24. Organization for breaching an obstacle.

- (a) The lead unit immediately reports and establishes overwatch, and/or returns fire, including immediate suppressive indirect fires. Normally, the battalion heavy mortars provide HE and smoke.
 - (b) The battalion seeks a bypass.
 - (c) The lead unit reconnoiters the obstacle.
 - (d) The battalion begins a hasty breach if bypass is not possible.
- (3) The lead company becomes the support force and provides overwatch. If the decision to breach is made, scouts provide flank security and the breaching force conducts the breaching operation. Battalions may be augmented with obstacle breaching equipment such as rocket-propelled line charges, bangalore torpedoes, and AVLB. These items should be well forward and attached to the breaching force.

- (4) After the support force is in position, and is calling for indirect HE and smoke, the breaching force moves to the near edge of the obstacle.
- (5) During breaching, company teams should maintain dispersion to avoid a “pile-up” in front of the obstacle. Tactical dispersion is a must.
- (6) Once near the obstacle, the breaching force establishes its own overwatch, and breaching-equipped vehicles begin breaching operations. APCs and BFVs remain near the obstacle during breaching operations so the breaching team is afforded cover and transport if heavy indirect fire impacts. Only one lane must be breached initially, but at least two vehicle lanes are usually required for a task force.

c. Techniques of Conducting a Breach.

- (1) The initial objective of a breach is to make a safe route to the far side. This is done by breaching foot and vehicle lanes through the obstacle. The number and type of lanes breached depend on—
 - The size of the breaching force.
 - The depth and density of the obstacle.
 - The equipment available.
 - (a) **Foot lanes.** If a mounted assault breach is not feasible, then at least one foot lane is needed for each assault company. This lane is normally 2 meters wide and is marked with white marking tape, flashlights, or chemical lights along its centerline. Full use is made of darkness, smoke cover, breaching devices (mechanical or explosive), and covering fires. Initial lanes may be breached in defiles that give cover and concealment to assault troops, even though these lanes may not be widened into vehicle lanes later. The bangalore torpedo will clear foot lanes through mines and wire obstacles. It clears a path 3 to 4 meters wide through wire entanglements. It will clear a narrow foot path through a minefield by exploding most of the antipersonnel and single-pulse-fuzed antitank mines of the minefield. Once there are foot lanes through the minefield, assault forces move through rapidly to neutralize any nearby enemy positions and secure the far side of the obstacle.
 - (b) **Vehicle lanes.** After the first breach is made, foot lanes may be widened to one-way vehicle lanes at least 5 meters wide. Vehicle lanes also may be breached

separately from foot lanes. Existing roads are used when possible, clearing mines along their entire width. The mine clearing line charge (MICLIC) is a trailer-mounted, rocket-projected, explosive line charge towed by a variety of combat vehicles to within 50 feet of the minefield. When projected across the minefield and exploded, it clears a vehicle lane 5 to 8 meters wide and 100 meters long.

- (2) The task force must be prepared to breach obstacles without engineer support using organic equipment. Company teams must be capable of executing counterobstacle battle drills. Thus, attached tank companies may need an infantry platoon to assist in hasty obstacle breaching. Techniques of breaching using organic equipment are—
 - Pushing a destroyed vehicle through a minefield.
 - Driving through wire obstacles.
 - Using an M88 with its blade lowered to conduct “mine-skimming.”
 - Using mineroller and plow.
- (3) Each vehicle could carry a grappling hook with rope to facilitate breaching of wire obstacles.

d. Marking the Lane.

- (1) The path must be clearly marked in order for vehicles to follow safely and quickly through a breached lane. When available, a hand-emplaced minefield marking set (HEMMS) or cleared lane marking system (CLAMS) is used, but field commanders must be innovative in the use of expedient methods to accomplish the mission. Temporary marking is replaced by standard marking materials as soon as the tactical situation permits. Some commonly used and readily available field-expedient lane marking items are —
 - Engineer cloth tape 2 inches wide staked down with tent pegs or rocks.
 - Paint or oil (hang a 5-gallon canon the back of the leading tank and punch a nail-hole in the bottom so that the liquid streams out. This signature will only last long enough to get a few vehicles through.)
 - Plow.
 - Rocks.
 - Lime, flour, or other visible powder (summer).

- Cinders (on snow).
- Smoke grenades.
- Expended shell casings.
- Toilet paper.
- Chemical lights or flashlights (at night).
- Pickets with engineer tape or chemlight tied to them.

- (2) Distinctive markers must show where the lane begins and ends. There is a tendency for most drivers to start maneuvering before they are out of the minefield.
- (3) After the lanes are cleared, the assault team moves through the obstacle and deploys on the far side. This is done by establishing defensive positions and firing on known or likely enemy locations. The breaching force must establish far-side security to antitank weapons range and allow the assault force room to pass through and deploy (see Figure 5-25).

e. Hasty Breach of Log Obstacles.

- (1) Abatises are reduced by placing explosive charges at the point where the tree is still attached. After detonation, severed trees are removed by available vehicles, or by hand.
- (2) Log cribs can be dismantled by hand or forced through with bulldozers.

f. Hasty Breach of a Tank Ditch. A properly emplaced tank ditch is a formidable obstacle. Because of the equipment and effort required to construct the ditch and because of its importance to the defender, it is probably mined with antitank and antipersonnel mines, and reinforced with wire. In addition, tank ditches are always covered by direct and indirect fires (see Figure 5-26, page 5-68). When the battalion encounters a tank ditch, it must quickly and aggressively perform the following:

- Report.
 - Establish an overwatch with support force.
 - Dispatch scouts or reconnaissance patrols to locate a bypass.
 - Use elements of the breaching force to reconnoiter the obstacle.
 - Begin hasty breaching if bypass is not available.
- (1) The hasty breach cannot be started without first gaining fire superiority over the defending enemy and/or obscuring his field of fire with smoke and indirect fires. This is required during daylight and during limited visibility.

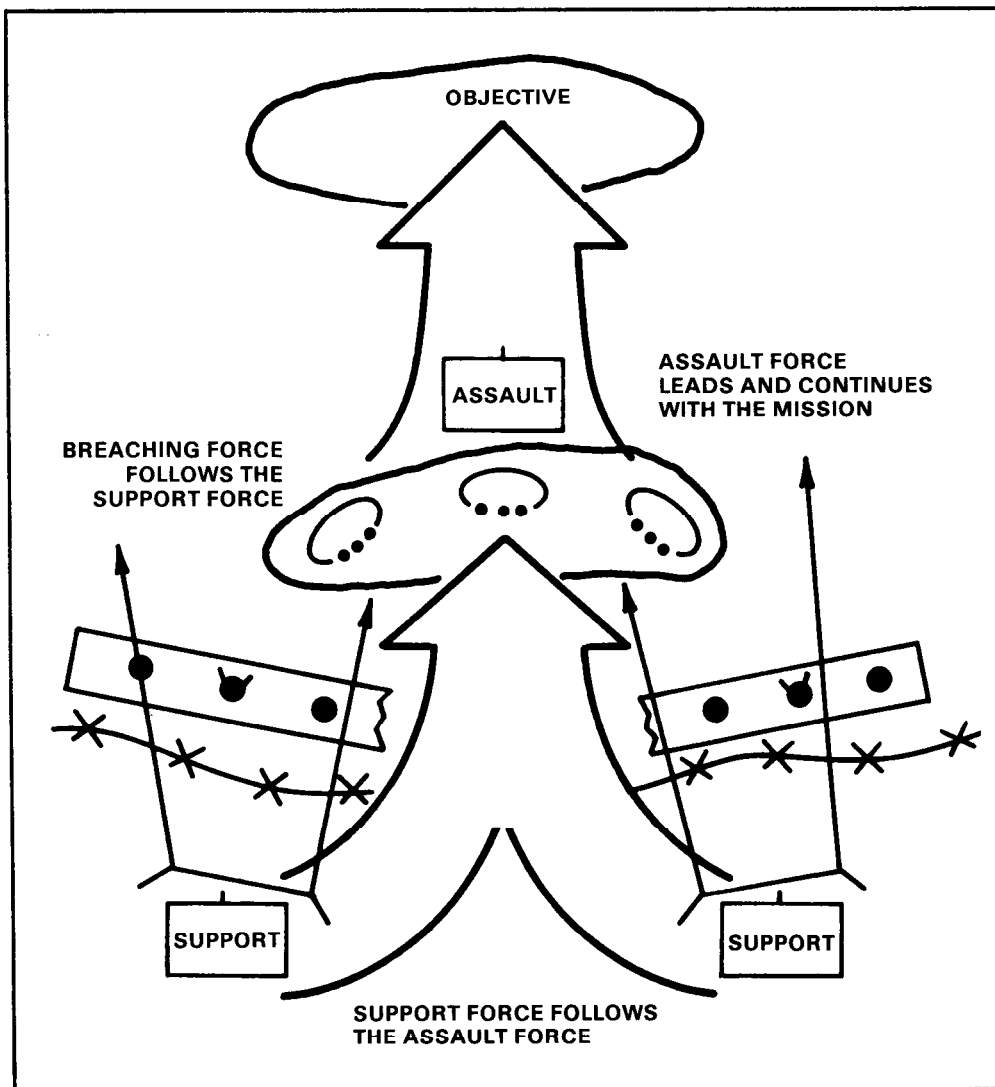

Figure 5-25. Assault force secures the far side.

- (2) Elements reconnoitering the obstacle attempt to locate weak spots. Any breaks in the wall or wire, or places where the ditch is partially filled or the banks are not steep, are potential crossing sites.
- (3) To begin the breach, artillery, mortars, CEVs, and tanks fire into and on top of the wall (spoil) on the enemy side. This is done to collapse the wall enough to partially fill the ditch, destroy wire, and detonate some mines. These fires are adjusted by the support force leader.

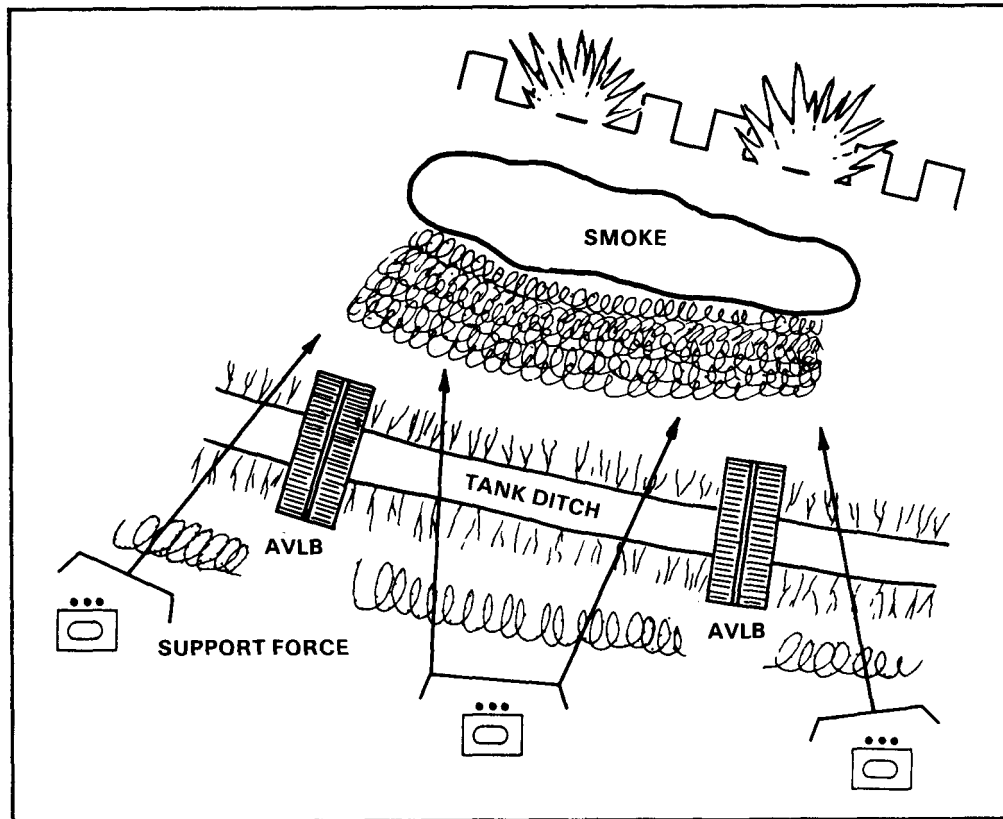

Figure 5-26. Actions at a tank ditch (bypass not possible).

- (4) Once the breaching force has cleared a lane to the ditch, engineers move forward with AVLBs. At least two are required. The breaching force assists in clearing mines and debris to allow the AVLBs to be positioned. AVLB can span gaps up to 60 feet.
- (5) If AVLBs are not available, then the tank ditch must be breached using CEVs, blade tanks, dozers, or explosive charges to break down the walls. Tanks may also drive up close to the edge of the ditch, and conduct repeated sharp turns to the left or right. Eventually the ditch walls will collapse on the rear side. Demolition can then be used to neutralize the far side.
- (6) Once the breaches are made, elements of the breaching force quickly cross and establish overwatch positions on the far side. As with minefield, the commander orders the assault force through to take the lead, followed by the breaching force, then the support force.

CHAPTER 6
COMBAT SUPPORT

The battalion task force commander uses combat support elements as combat multipliers to enhance the combat power of his maneuver companies. Knowing combat support capabilities, employing them appropriately, and synchronizing their operations are essential to applying superior combat power at the decisive time and place.

CONTENTS		
PARAGRAPH		PAGE
Section I.	RELATIONSHIPS AND RESPONSIBILITIES	6-2
6-1	Command and Support Relationships	6-2
6-2	Combat Support to Company Teams	6-3
Section II.	INDIRECT FIRE SUPPORT	6-3
6-3	Planning Considerations	6-4
6-4	Coordination	6-8
6-5	Targets	6-9
6-6	Multiple Targets and Targeting	6-11
6-7	Other Fires	6-13
6-8	Specialized Conventional Munitions	6-14
6-9	Mortars	6-16
6-10	Naval Gunfire	6-17
Section III.	TACTICAL AIR SUPPORT	6-17
6-11	Offensive Air Support	6-17
6-12	Close Air Support	6-19
6-13	Joint Air Attack Team	6-21
Section IV.	ARMY AVIATION SUPPORT	6-22
6-14	Army Aviation Assets	6-22
6-15	Synchronization of Attack Helicopters	6-22
Section V.	AIR DEFENSE SUPPORT	6-24
6-16	Passive and Active Air Defense	6-24
6-17	Relationships and Missions	6-25
6-18	Systems and Characteristics	6-25
6-19	Weapons Control	6-26
6-20	Early Warning	6-26
6-21	Employment Considerations	6-27
Section VI.	ENGINEER SUPPORT	6-29
6-22	Capabilities	6-29
6-23	Employment Considerations	6-30
6-24	Engineers Fighting as Infantry	6-32

PARAGRAPH	PAGE
Section VII. NUCLEAR, BIOLOGICAL, AND CHEMICAL SUPPORT	6-32
6-25 Chemical Company	6-32
6-26 NBC Reconnaissance Platoon	6-33
6-27 Smoke Employment	6-33
Section VIII. INTELLIGENCE AND ELECTRONIC WARFARE SUPPORT	6-41
6-28 Interrogation Team	6-41
6-29 Ground Surveillance Radar	6-42

Section I. RELATIONSHIPS AND RESPONSIBILITIES

Combat support elements provide the task force significant amounts of additional combat power. These elements support the task force under established command and support relationships. Regardless of the relationship of the combat support element to the task force, the task force commander is responsible for integration and synchronization of available combat support to accomplish his mission.

6-1. COMMAND AND SUPPORT RELATIONSHIPS

- a. Specific applications of the command and support relationships are in the discussion of combat support elements throughout this chapter. Table 6-1 provides an illustration of the relationship between the task force and combat support elements.
- b. The leader of a combat support element that is attached, under OPCON, or DS to the task force also serves as a special staff officer to the task force commander. During planning, preparation, and execution of the task force mission, he provides assistance, advice, and recommendations on employment of his unit to the task force commander and staff. He employs his unit as directed by the task force commander.

UNIT	ATTACHED	OPCON	DS	GS
Under Command/ Control of—	TF CDR	TF CDR	Parent Unit	Parent Unit
Task Organized by—	TF	Parent Unit	Parent Unit	Parent Unit
Receives Missions, Tasks, and Priorities from—	TF	TF	TF	Parent Unit
Positioned by—	TF	TF	Parent Unit*	Parent Unit*
Maintains Communications and Liaison with—	TF	TF and Parent Unit	TF and Parent Unit	Parent Unit
Receives CSS from—	TF***	Parent Unit**	Parent Unit**	Parent Unit

* With specific approval of the task force commander if within the task force area of operations. (Any unit in the task force area requires positioning approval.)

** CSS requirements beyond the capability of the parent unit are provided by the task force after specific request and coordination between the task force, parent unit, and brigade headquarters has been made.

*** Attached element brings an appropriate slice of combat service support equipment and personnel to supplement the task force's assets.

Table 6-1. Task force command and support relationships.

6-2. COMBAT SUPPORT TO COMPANY TEAMS

As a result of his estimate of the situation, the task force commander decides how to employ his combat support assets. He retains centralized control of the organic and attached combat support assets by specifying tasks and assigning priority of support to his subordinate company teams. However, in some circumstances a combat support element may need to be attached to a company team along with sufficient logistical support.

Section II. INDIRECT FIRE SUPPORT

The mission of fire support is to mass firepower to delay, disrupt, or destroy enemy forces in support of the scheme of maneuver.

6-3. PLANNING CONSIDERATIONS

- a. The task force commander and his FSO integrate the firepower of mortars, field artillery, close air support, and, when available, naval gunfire with the maneuver of combat units (including available attack helicopters) to defeat the enemy.
- b. One of the commander's greatest challenges is in synchronizing and concentrating all of his combat power at the critical time and place. There will be a multitude of targets to engage in a short time and a time lag from the time the decision is made to use supporting fires until the target is hit. The commander alone will not have the time to integrate all the weapons available to him in terms of concentrated combat power. The FSO assists the commander by developing the fire support plan concurrently with the maneuver plan. During the battle, the FSO and fire support section monitor the execution of fire support to ensure compliance with the commander's intent and to provide continuous support.
- c. In using fire support, the task force commander considers the following.
 - (1) **Fire support to complement maneuver systems.** Fires are used to accomplish missions that maneuver forces cannot, or that would otherwise divert maneuver forces from the main effort, such as suppressing an enemy position to allow concentration of maneuver forces elsewhere.
 - (2) **Surprise.** Massed surprise fires are most effective — the destruction that can be achieved by supporting fire is proportional to the preparedness of the enemy.
 - (3) **Most effective roles.** To best integrate fire support, the task force commander must know the capabilities and limitations of all supporting fires and ensure that fire support is used where and when it will be most effective. The combined fires of an FA battalion and the battalion's mortar platoon can cover less than a square kilometer and, therefore, must be judiciously planned.
- d. The planning and coordination processes begin when the mission is received or assumed, and they never stop. The commander, XO, S3, S2, and FSO interact throughout the planning and execution of the mission to ensure that fire planning is a continuing process.
- e. As the task force commander develops his plan for the employment of maneuver forces, he and the FSO develop the best use of fire support resources by determining:

- Which subordinate units to weight with fire support.
 - What targets to attack.
 - What fire support means to use.
 - What target effect to achieve.
 - What priorities to set for engaging targets and allocating fires.
- f. The commander must ensure that he clearly states his intent for fire support, that his fire support plan is developed accordingly, that all available fire support is considered, and that each phase of the maneuver plan is supported by the fire plan. The FSO must ensure that he understands the commander's requirements for fire support. Areas that the commander must coordinate with the FSO include the following.
- (1) Scheme of maneuver — area of operation, timing of advance, rate of movement, passage of lines, army aviation in sector.
 - (2) Priority of fires — which unit has priority of artillery and/or mortar fires.
 - (3) Targets of concern — those targets which if not fired upon will seriously impede mission accomplishment.
 - (4) Priority targets — what the priority targets are and how long they will be in effect.
 - (5) Effects of fire —
 - (a) *Suppression* limits the ability of personnel in the target area to perform their jobs. The effects of suppressive fire last only as long as the fires continue.
 - (b) *Neutralization* temporarily knocks the target out of action, producing 10 percent or more casualties. Most planned missions are neutralization fires.
 - (c) *Destruction* renders the target ineffective for a prolonged period of time. Destruction requires large quantities of ammunition or special munitions.
 - (6) Use of mortars — mission, target effects, control, displacement, locations, and ammunition mix.
 - (7) Close air support — in coordination with the FAC, what is available, when it is available, and how it will be used (including target selection and desired effects).
 - (8) Fire support coordination measures — existing or proposed permissive or restrictive control measures established by higher headquarters or the task force itself.

- (9) Ammunition restriction — limitation on the use of smoke, improved conventional munitions, or other ammunition (including established CSRs).
- g. At battalion task force level, the FSO is assisted by the FSS and company FISTs. They provide personnel for continuous planning and coordination of supporting fires.
 - (1) The FSS, battalion S3 Air, and advisers from the other fire support means are collocated in the battalion main CP for the planning and coordination of fire support and form the battalion fire support element (FSE). A TACCS from the TACP is part of the FSE and, if naval air or naval gunfire support is available, the FSE may also include a supporting arms liaison team (SALT) or shore fire control party (SFCP). The FSE coordinates and works closely with the brigade FSE, the FSE of other battalions, the DS field artillery battalion FDC, the S2 and the S3, the mortar platoon leader, the engineer platoon leader, and the company FISTs.
 - (2) The company FIST provides the fire support planning and coordination required by the company. The FISTs are provided by the DS FA battalion. The FIST is supervised by a field artillery lieutenant (company FSO) who is the company commander's FSCoord. Occasionally, spotter teams for naval gunfire (NGF) and forward air controllers for CAS will collocate at the company to advise and assist the company FSO in the use of their assets.
- h. The planning process determines how fire support will be used — what type of targets will be attacked, when, and with what means. The plan is flexible to accommodate the unexpected in combat.
 - (1) The depth and detail of fire support planning depends on how much time is available. Many of the fire support actions that occur in response to battle situations are established in SOPs or directed in FRAGOs.
 - (2) Fire support planning is continuous and concurrent at all levels.
 - (3) The fire support plan outlines the way artillery, mortars, and close air support will be used to complement the scheme of maneuver, and it provides instructions for executing those fires. It ranks targets in priority order, matches them with the available fire support systems, eliminates duplication with brigade targets, and allows fires to be executed quickly, without specific direction from the commander once the battle starts. A task force fire support plan may include:

- A general concept of how fires will support the battle.
 - A target list that includes locations where fires are expected or likely to be used. Known enemy locations should be carefully targeted, but too many targets complicate the fire plan and delay fires.
 - A priority of fires telling which element will receive fire support in case of conflicting needs.
 - A priority of targets telling which type of mission to fire first.
 - An allocation of priority targets and FPFs, if available.
 - An execution matrix for indirect fire weapons.
 - Informal airspace coordination areas.
 - Coordination measures for providing troop safety and synchronizing supporting fires.
- (4) The fire support plan is developed by the FSO with assistance and input from the FAC, company FSOs, heavy mortar platoon leader, S2, and S3. A fire plan is constantly refined or modified as the operation continues, so as to provide responsive fires to the task force wherever they are needed.
- (5) At task force level, the FSO disseminates, in the OPORD, a fire plan to support the task force. This plan usually contains all the elements listed above, and it is modified as company team fire plans are received. Updated fire plans are sent back to FISTs and disseminated to the mortar platoon, DS battalion FDC, and brigade FSE.
- (6) Company FSOs accompany the company team commanders to receive the task force OPORD. This allows the company FSOs to hear the concept of the operation simultaneously with their commanders. Within minutes after the OPORD is given, they can get together to develop their fire support plans. This arrangement also allows the task force FSO to brief the company FSOs on plans the task force commander wants implemented. Written fire plans are disseminated, questions answered quickly, and conflicts resolved with minimum confusion.
- i. The task force commander and FSO may develop an event-oriented scheme of fire support in conjunction with developing the selected course of action. This fire support plan will require a specific FO, company FSO, or other element to fire a specific indirect fire system at a designated target when or if a specific event occurs. For example, when the lead platoon of Team B

reaches Highway 40, the B team FSO will fire group A1B; when Company C begins crossing phase line Red, an FO attached to the scout platoon will fire smoke from the mortar platoon on targets AB2712 and AB2713; when the enemy reaches and attempts to breach the obstacle at NA395678, the Team A FSO will fire FASCAM on target AB2203; if the enemy moves to the south of checkpoint 6, the Company D FSO will shift fire from target AB2521 to engage the lead elements of the enemy column. This scheme of fire support is a result of IPB, and forms the basis of the fire support execution matrix.

6-4. COORDINATION

- a. Effective fire support depends on centralized planning and decentralized execution and coordination. Based on the commander's intent and concept of operations, the FSOs and FISTs execute the plan during the battle with minimum specific instruction. The battalion FSOs coordination includes all of the following actions.
 - Ensure that the DS battalion FDC, the mortar platoon FDC, and any other supporting elements have the correct fire support plan and understand their portion of it and the supported unit's mission. Fire support rehearsals are conducted before the battle.
 - Verify that the task force mortars are in position to support.
 - Keep the brigade FSE and the supporting field artillery main CP informed of the tactical situation.
 - Select fire support means to attack targets during the battle.
 - Ensure that the task force commander and S3 are kept informed concerning any degradation of fire support.
 - Modify the fire support plan during the battle to react to battlefield changes, and make sure that FISTs are aware of changes.
 - Coordinate requests for additional fire support with higher level fire support elements.
 - Monitor execution of the fire support plan. Normally, the task force FSO does not personally direct adjust fires. He usually directs a company FSO to do so.
- b. The task force FSO must ensure that the plan developed remains supportable. He must immediately inform the battalion commander if there is not enough fire support allocated to make the

- plan work, or if circumstances dictate changes in the plan. To do this, he must be forward with the tactical CP during the battle, and will normally ride with the commander.
- c. The FSO must keep abreast of the tactical situation and coordinate all fire support affecting his zone, including that requested by the task force. He ensures that fires do not jeopardize troop safety, interfere with other fire support means, or disrupt adjacent unit operations. For this coordination, the FSO relies on the FSE at the main CP to keep him abreast of all information including fire support coordination measures, fire support asset locations, and fire support status.
 - d. During the battle, shifts in priorities of fire, changes to the fire plan to support a changed scheme of maneuver, and requests for immediate CAS are all made well forward by the FSO and FAC at the tactical CP. The FSE at the main CP continues its planning responsibilities and provides backup support to the tactical CP.
 - e. The task force FSO will normally be limited to operating on one fire support net when forward. The FSE must keep the FSO and other elements of the task force informed of fire support status and keep the FA abreast of the tactical situation of the task force. Likewise, the FSE must be kept informed of the forward tactical situation and of actions of the mortar platoon. Frequently, the FSE will have to relay calls for fire. The FSE must ensure communications with the forward FIST and the supporting FA system. In the event of loss of the FSE, the FSO must designate the least committed FIST to assume the FSE functions.
 - f. Lateral coordination between the battalion and company FSOs, the FSE, and the mortar platoon is the key to responsive and effective fires. The TF fire support net is used for this coordination.

6-5. TARGETS

Every target can be classified as either a target of opportunity or a planned target.

- a. A *target of opportunity* is one that has not been planned.
- b. A *planned target* is one on which fire is prearranged. Artillery and mortars precalculate firing data to expedite the execution of fires. To enhance accuracy, resection, hasty survey, GLLD polar location, or registration may be used to determine precise target locations. A planned target may be scheduled or on-call.

- (1) A *scheduled target* is a planned target on which fire is to be delivered at a specific time or upon occurrence of a specific event or maneuver phase.
- (2) An *on-call target* is a planned target to be fired on request rather than in accordance with a time schedule or specific event.
 - (a) A *priority target* is a planned target that takes precedence over other targets. A firing unit is prepared to engage it whenever the unit is not firing another mission. The maneuver commander designates priority targets. He should provide specific guidance to the FSCOORD as to when certain targets become priority targets, when they cease to be priority targets, the desired effects on the target, and any special type of ammunition to be used (such as smoke or VT). Priority targets are usually allocated one per artillery battery or mortar platoon. FA priority targets are allocated to the task force by the brigade commander. FA and mortar priority targets may be suballocated to company teams or other elements by the task force commander. A type of priority target used in a defensive situation is the final protective fire.
 - (b) *Indirect final protective fires (FPFs)* are a type of priority target used to create a barrier that impedes enemy dismounted movement across defensive lines or areas. This fire is integrated with the battalion commander's defensive plans. The brigade commander allocates priority targets to a maneuver battalion task force, and they may be further allocated to companies for use as FPFs. The task force commander may also allocate one FPF from the mortar platoon or one for each mortar section. The size of the FPF depends on the type of weapon:
 - 107-mm mortar platoon (6-gun): 300 by 40 meters.
 - 107-mm mortar section (3-gun): 150 by 40 meters.
 - 155-mm howitzer battery (6-gun): 300 by 50 meters.
 - 155-mm howitzer platoon (4-gun): 200 by 50 meters.
 The maneuver commander is responsible for the location of each FPF. It may be any distance from the friendly position that supports the current tactical plan (normally 200 to 400 meters). Authority to call for the FPF is given to the maneuver commander (the company

commander or platoon leader) to whom the FPF is allocated. The FSO is responsible for:

- Reporting the desired location of the FPF to the FDC.
- Adjusting the (by weapon) on the desired location.
- Transmitting the call to fire FPF to the supporting FDC.

6-6. MULTIPLE TARGETS AND TARGETING

Targets and targeting are discussed in detail in FM 6-20 and in FM 101-5-1. The following discussion covers only multiple targets and targeting techniques of most concern to the task force commander. Multiple targets call for special considerations. When fire is desired on several targets, groups, series, or programs of targets may be established. As with other targets, they may be planned at TF level, but must be approved by the DS battalion.

- a. **Group of Targets.** A group of targets consists of two or more targets on which simultaneous fires are desired. A group is graphically portrayed by circling the targets and identifying them with a group designation (Figure 6-1). The group designation consists of the letters assigned to the maneuver brigade or the division artillery TOC with a number inserted between them. The fact that targets are included in a group does not preclude the attack of individual targets within the group.

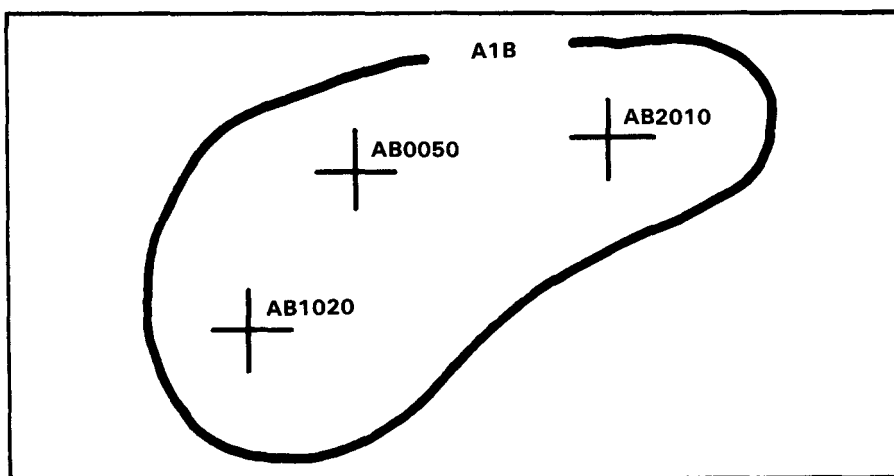

Figure 6-1. Example symbol for a group of targets.

- (1) **Offense.** This method is used when the battalion commander wants to attack several targets simultaneously or to suppress some enemy positions as he attacks others.

(2) **Defense.** In the defense, a group of targets can be used to destroy enemy stopped at minefield, or to destroy vehicles waiting to cross rivers or bridges. Individual targets in the group can be selected based on how the battalion commander thinks the enemy would form at these activities.

b. **Series of Targets.** A series of targets is a number of targets or groups of targets planned to be fired in a predetermined sequence to support the scheme of maneuver. A series may be either on call or scheduled. Graphically, a series is shown as individual targets or groups of targets within a prescribed area. The series is given a code name (Figure 6-2). Once a series is initiated, targets and groups of targets within the series are fired on a predetermined time sequence. Simultaneous engagement of targets in a group within a series is not mandatory. Phasing of targets within a series is as requested by the initiator or as determined by the fire planner, based on the nature of the targets and the desires of the force commander. The fact that a series of targets has been formed does not preclude the attack of individual targets or groups of targets within the series.

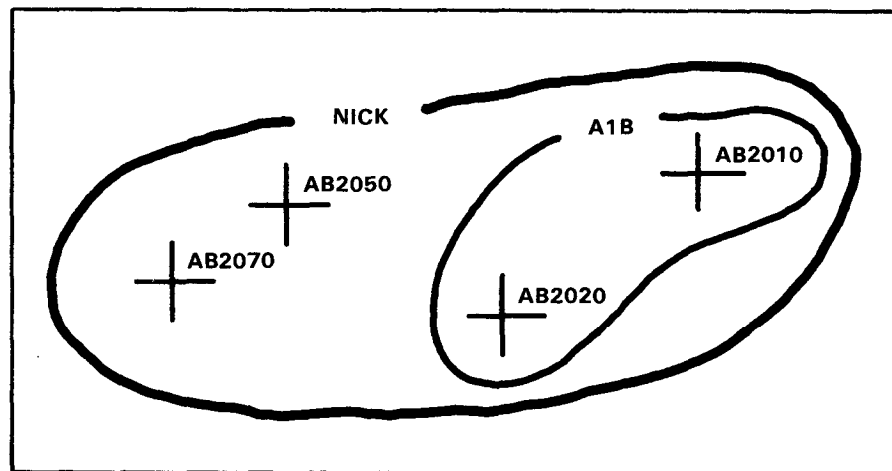

Figure 6-2. Example symbol for a series of targets.

(1) **Offense.** The series should be planned to support the assault timing on the objective. The series allows for fires to shift automatically to engage individual targets or groups of targets as the task force fights across an objective. The series can also be planned for targets beyond the objective.

(2) **Defense.** In the defense, the series allows for fires which, once again, are tied to speed; but in this case it is the speed at which the enemy will attack. A series of linear targets

may be planned to destroy the enemy attack echelons. Attack of linear targets 1,000 meters apart (3 minutes at 20 kilometers per hour) will keep fire automatically falling on the enemy.

- c. **Programs of Targets.** A program is a number of planned targets of a similar kind. All targets in a particular program are of the same type (for example, all enemy ADA, all mortar targets). A program may be scheduled or on call. Once a program is initiated, targets within the program are fired on a predetermined time sequence as listed in the schedule. At battalion level in both the offense and defense, a suppression of enemy air defenses (SEAD) program is the typical program fired.

6-7. OTHER FIRES

Commanders have several other fire support techniques available to complement the task force maneuver. Those most commonly used by the task force commander are preparation fires and interdiction fires.

- a. **Preparation Fires.** These fires provide an intense volume of fire delivered in accordance with a time schedule to support an attack. The preparation is normally planned at brigade or higher echelon. The battalion provides input for development of preparation fires.
 - (1) The fire normally commences before LD time. It may start at any prescribed time or may be on call. The duration of the preparation is influenced by fire support needs of the entire force, number of targets and firing assets, and ammunition available.
 - (2) A preparation is phased to permit successive attacks on certain types of targets. The first phase provides for the early attack of hostile fire support means and all observation systems. The second phase includes attack of command posts, communication facilities, assembly areas, and reserves. The final phase includes attack of defensive areas in the forward portion of the enemy position and targets that pose an immediate threat to the attacking force.
 - (3) When assigning fire support systems to targets in the preparation, planners make sure that some firing units remain available to attack targets of opportunity.
 - (4) Plans for firing preparations are continually updated to delete old targets and incorporate new ones. The division

or brigade commander, with the advice of his FSCOORD, makes the final determination as to whether the preparation should be fired.

- (5) The task force FSO must ensure that the preparation fires, especially those fired during the final phase on forward enemy positions, do not interfere with the task force scheme of maneuver. This is critical when the task force commander plans to infiltrate dismounted infantry forward of the LD before LD time. The FSO will ensure that any fires within the task force area of operations have the approval of the task force commander.
- b. **Harassing Fires.** Harassing fires are delivered on confirmed and suspected enemy locations for the purpose of disturbing the rest, curtailing the movement, and lowering the morale of enemy troops by the threat of casualties or loss of equipment. Fires may also be delivered on selected terrain for the purpose of denying the enemy the unrestricted use of these areas or to delay enemy second-echelon elements and prevent them from joining the battle.

6-8. SPECIALIZED CONVENTIONAL MUNITIONS

The task force commander must know the capabilities of several types of munitions that can aid maneuver operations.

- a. **Artillery-Delivered Smoke.** Artillery-delivered smoke is used to obscure or screen. WP provides a quick smoke build-up. HC, under the right weather conditions, provides sustained concealment.
 - (1) **Obscuration fire.** Placed on or near the enemy, this category of firepower uses smoke and WP ammunition to isolate the enemy and obscure his view of the battlefield. Because smoke is susceptible to changes in wind direction and the configuration of the terrain, its use must be coordinated with the maneuver commander and all other friendly units affected by the operation.
 - (2) **Screening fire.** Screening fire also involves the use of smoke and WP. Screening fire, however, is used to mask friendly maneuvering elements in order to disguise the nature of their operations.
- b. **Illumination.** Even with the greater capability of night observation devices of US forces over potential adversaries, illumination fires are planned to assist command and control and, to a lesser extent, target acquisition. Although always

planned, illumination fires are normally on order of the TF commander. The following are considerations for employing illumination:

- (1) Illumination fires are often necessary to assist dismounted operations.
 - (2) Since the amount of illumination in basic loads is often low, expenditures must be monitored.
 - (3) Wind and other atmospheric conditions can affect the time it takes to get effective illumination.
- c. **Scatterable Mines.** The family of scatterable mines (FASCAM) gives the commander a rapid, flexible, and effective means of delaying, canalizing, harassing, or wearing down enemy forces. Field artillery delivered scatterable mines are used in both defensive and offensive operations.
- (1) The brigade commander may release authority for the task force commander to employ short-duration FASCAM minefield. FASCAM employment is then planned by the task force commander and S3 in coordination with the engineer, S2, and FSO. Scatterable mines are included in the maneuver and obstacle plan. Upon approval of this plan, the FSO integrates field artillery delivered scatterable mines into the task force fire support plan. The scatterable mines are then fired as directed by the task force commander.
 - (2) The standard low density (target of opportunity) field artillery delivered scatterable minefield requires that a total of 30 rounds be fired to form a pattern roughly 400 x 400 meters. Employment time is generally 15 minutes (planned) to 30 minutes or longer (unplanned) from the call for fire. The submunitions are set to self-detonate in either less than 24 hours (short duration) or more than 24 hours (long duration). Exact self-destruct times are classified and are in TM 43-0001-28-1. Authority to employ long duration self-destruct scatterable mines is normally not delegated to task force level.
 - (3) A FASCAM minefield is observable on the ground. These mines are most effective when tied into existing or reinforcing obstacles, and as with other obstacles, FASCAM minefield must be covered by observation and direct and indirect fires.
 - (4) The firing unit is responsible for reporting the location of the minefield to the brigade FSE. The brigade then informs higher, lower, and adjacent units of its location.

- (5) The task force FSE notifies the engineer and other elements of the main CP. The main CP notifies subordinates and maintains the location and status of the minefield until it self-destructs.
- (6) Aerial employment of scatterable mines may be requested from the division's aviation brigade. (See TC 6-20-5 for more information on employment of scatterable mines.)
- d. **Laser Guided.** The Copperhead round is effective against stationary targets out to 5,000 meters from the laser designator (aerial or ground). Depending on the skill of the operator, Copperhead can hit moving targets at 3,000-4,000 meters. However, it takes almost 5 minutes from the initial call for fire for the round to be fired, which limits the utility of this round for targets of opportunity. In addition, the requirement for the laser designator to "spot" the target for the final 13 seconds of flight restricts the utility of this round.

6-9. MORTARS

- a. The mortar platoon can operate as a platoon or as two firing sections. When operating in split sections, the configuration is one FDC and three gun tracks per section. The size of the sections may vary but they must consist of at least one gun track and an FDC.
- b. The mortar platoon leader assists the FSO in developing fire plans, but during operations his function is leading his platoon.
- c. The S3 is responsible for the positioning of mortars, but he normally delegates this positioning authority to the FSO. The mortar platoon leader recommends positions to accomplish his assigned missions. Because of range limitations, mortars must be emplaced well forward to provide continuous and effective fire support. This frequently puts mortars in company positions in the defense or moving with companies in mobile operations. The mortar platoon leader is responsible for continuous coordination with the company in whose area he is positioned or with whom he is moving.
- d. The normal mission of the platoon is to provide fire support to the entire task force (general support) under the direction of the FSO. During the planning phase and subsequent coordination, the FSO determines the targets that are to be engaged by mortars. The FSE monitors the mortar FDC nets.
- e. In fast-moving offensive or defensive operations where there is a need for decentralized control, the mortar platoon or a mortar

section may be given a direct support mission or attached to one company. In this case, the mortar element is on the net of the supported company and moves and positions to support that element at the direction of the company FSO.

- f. Prepositioned resupply should be considered for mortars during the defense. It may be placed on both initial and supplementary positions. In addition, the combat trains normally include emergency mortar resupply. (Detailed coverage of mortar platoon operations is in FM 7-90.)

6-10. NAVAL GUNFIRE

- a. When operating near a coastline with gunfire support ships within range, naval gunfire can be an effective fire support means.
- b. US Army units have only a limited organic capability to control naval air or naval gunfire. This capability is normally provided to a division by the US Marine Corps in the form of an air naval gunfire liaison company (ANGLICO). There are two organizations within the ANGLICO. Depending on which organization is available, the battalion task force will receive either a shore fire control party (SFCP) or a battalion supporting arms liaison team (SALT) and firepower control teams (FCT). These ANGLICO elements have the mission to request, coordinate, and control naval air and naval gunfire.

Section III. TACTICAL AIR SUPPORT

Tactical air support provided by the USAF consists of offensive air support (OAS), counterair, air interdiction, and tactical airlift (Figure 6-3, page 6-18).

6-11. OFFENSIVE AIR SUPPORT

- a. OAS is the element of tactical air support normally conducted in support of ground operations. It consists of tactical air reconnaissance, battlefield air interdiction, and close air support.
 - (1) Tactical air reconnaissance is the acquisition of intelligence information using visual observation and/or sensors in aircraft.
 - (2) Battlefield air interdiction is air action against enemy forces and resources that are in a position to directly affect friendly forces.

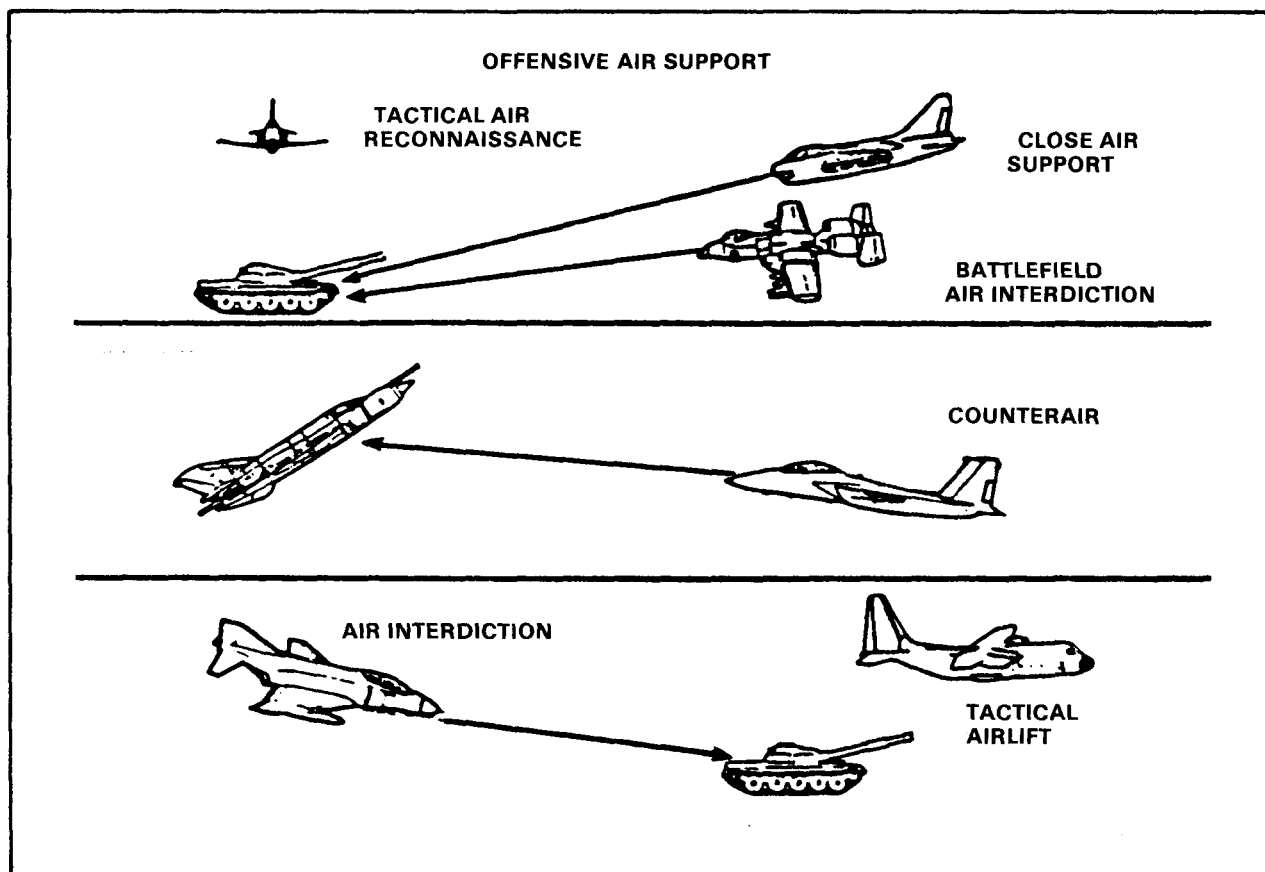

Figure 6-3. Tactical air support.

- (3) Close air support (CAS) is air action against targets close to friendly forces. Each mission must be carefully controlled and requires detailed integration with the fire and movement of those forces. This is the role in which USAF aircraft will normally support the task force. CAS provides a variety of ordnance and high payloads. The payload of a single A-10 is the equivalent of firing five to seven volleys from a 24-tube, 155-mm howitzer artillery battalion.
- b. The use of aircraft to support ground forces is subject to the following planning considerations.
- (1) Air support is not available at all times. Even when planned, it may be diverted to a higher priority mission (immediate).
 - (2) Immediate requests may restrict indirect fires and will come with whatever ordnance has already been loaded — not necessarily the optimum weapon for a particular target.

- (3) Air support may be limited by weather and enemy air defense systems.
- (4) Different support aircraft have varying capabilities to remain on station (loiter time).
- (5) Target identification is difficult, so marking of enemy and friendly locations is required when in close contact.
- (6) As long as the enemy has an effective air force, the emphasis will be on counterair. As the battle progresses and the enemy's air capability is reduced, the emphasis will shift to CAS or other OAS.

6-12. CLOSE AIR SUPPORT

- a. A tactical air control party (TACP) operates with the task force to advise the commander and his staff on integration of close air support with ground operations and to coordinate and direct close air strikes. The TACP consists of a forward air controller (FAC) and two tactical aircraft command and control specialists. Normally, the FAC operates with the command group in a tracked vehicle provided by the task force.
- b. Tactical air strikes are normally controlled by forward air controllers. The FAC is a fighter pilot who is familiar with the ground tactical situation and is trained to control strikes. In an emergency, when a FAC is not available, an artillery fire support team or the leader on the scene can perform the FAC function. The basic requirement is to locate and describe the target and friendly position for the fighter pilot. This information may be relayed to the pilot, using any means available. Normally, the fighter aircraft employs only UHF radio equipment for voice communication. The ground commander can use FM to contact aerial FACs, ALOs, and Army aircraft, all of whom have a UHF relay capability.
- c. CAS missions may be either preplanned or immediate. Preplanned missions are requested a day ahead through S3 Air channels. Preplanned missions allow detailed coordination and integration of maneuver, CAS, and other combat support elements into the tactical plan. They also allow ordnance loads to be tailored precisely to the enemy forces to be attacked. At task force level, preplanned CAS missions are usually planned in support of deliberate attacks because times on targets are fixed. Preplanned missions do have a measure of flexibility in that the location of the strike can be adjusted by the TACP after the aircraft arrive.

- d. Requests for planned CAS missions are developed and listed in priority order during the planning phase. The FSO, S2, and ALO determine the suitability of the target for air attack and consider potential airspace conflict. CAS requests are then forwarded to brigade. The brigade informs the battalion of the missions that were approved, and the fire support plan is adjusted.
- e. Immediate missions are most frequently used by the task force. Immediate requests are filled by aircraft on ground alert or by diverting aircraft from other missions. Requests for immediate CAS go directly from the task force FAC through Air Force channels and are processed unless intermediate monitoring headquarters disapprove the request within 5 minutes. Immediate missions normally take at least 30 minutes to arrive on station.
- f. The FAC must position himself to control the friendly aircraft. He notifies the task force commander that friendly aircraft are inbound. This warning is retransmitted to the task force to prevent mistaken engagement of friendly aircraft during the strike. He gives the aircraft personnel a briefing on the friendly and enemy situation. Positive identification of friendly forces must be made before the strike. This may require marking actions by forward elements (for example, colored smoke grenades) or marking of the target area by artillery, and mortars.
- g. The FAC and FSO coordinate airspace coordination areas (ACAs) with brigade and the task force's senior air defense representative. ACAs are normally developed and coordinated by brigades with recommendations from the task force. ACAs are either two-dimensional (informal) or three-dimensional blocks of airspace whose purpose is to give friendly aircraft the airspace needed to enter, attack enemy targets, and exit. Friendly indirect fire weapons are not allowed to fire into ACAs. The size of ACAs is a function of the type of aircraft, terrain, and CAS tactics required. ACAs are selected to allow both effective CAS tactics and minimum restriction of indirect fires. ACAs must follow prominent terrain to allow identification by pilots and have sufficient room for aircraft maneuver. A planning figure for ACA width that permits aircraft to employ proper attack tactics is 5 to 6 kilometers. Ingress and egress corridors can be as narrow as 1 kilometer and are usually keyed to prominent terrain features such as ridgelines, valleys, or roads.
- h. Insofar as possible, ACAs are coordinated to decrease a friendly aircraft's vulnerability. In addition, engagement priorities for direct fire weapons are given to destruction of enemy ADA weapons when CAS is being used.

- i. Because of the difficulty in coordinating optimum ACAs, timing ACAs is important. They should be implemented just before arrival of aircraft and be cancelled immediately as the aircraft leave.

6-13. JOINT AIR ATTACK TEAM

- a. The joint air attack team (JAAT) is a combination of US Army attack helicopters and US Air Force close support aircraft (normally A-10's) operating together to locate and attack high priority, lucrative targets. Simultaneously employing attack helicopters and A-10's against the same target array increases the lethality and survivability of both systems. The JAAT operates in concert with field artillery or mortars, air defense artillery, and ground maneuver forces against enemy armored formations, command vehicles, and enemy air defenses. Information flow between the maneuver commander, the attack helicopter team leader, and the FAC is essential.
- b. The JAAT is best employed against armor formations on the move. It is least effective when attacking strongly fortified, dug-in positions. During offensive operations, the JAAT can best be employed against counterattacks. During defensive operations, the team is used to destroy or disrupt enemy formations before they reach the FLOT, to reinforce committed ground maneuver units, to blunt enemy breakthroughs, to provide vital intelligence about enemy strengths and locations, or to form an independent force to attack enemy forces attempting to bypass the battle area.
- c. A JAAT is rarely formed and executed at the battalion level. JAATs are coordinated and executed by brigades because it takes at least 30 minutes to coordinate and get one assembled. The JAAT is controlled by the attack helicopter leader. When JAATs are employed in the task force sector, designation of specific engagement areas, coordination of supporting fires, designation of enemy and friendly locations, and the other specifics of directing the JAAT will be made by the task force commander through the attack helicopter leader.
- d. The task force commander, with the advice of his FSO and FAC, may initiate the request for a JAAT mission through the normal close air support channel (immediate if necessary), specifying the JAAT mission. Task force requests may be approved and executed at brigade level if the attack helicopters are in an OPCON status.

Section IV. ARMY AVIATION SUPPORT

Army aviation assets can move rapidly about the battlefield providing combat, combat support, and combat service support as missions require.

6-14. ARMY AVIATION ASSETS

- a. Aviation assets are centralized at division and corps level. The aviation brigade is normally employed by division as a brigade and no less than an aviation battalion.
- b. Army aviation provides the division commander a responsive, mobile, and flexible combat multiplier. Attack helicopters can mass rapidly and concentrate their firepower against enemy armor and mechanized units. Scout helicopters aid the ground commander in command and control and perform reconnaissance and observation missions. Utility helicopters provide the commander the assets needed to conduct air assault operations and move supplies and equipment to critical points on the battlefield. The division aviation brigade is the primary aviation resource for the division's maneuver brigades and their tank and infantry battalion task forces. The aviation brigade provides the division commander with an antiarmor and reconnaissance capability and troop and equipment movement capability not impeded by terrain.

6-15. SYNCHRONIZATION OF ATTACK HELICOPTERS

- a. **Employment.** A maneuver brigade may receive an attack helicopter battalion (ATKHB) OPCON for a specific mission or time period. The battalion is the smallest aviation unit that is placed OPCON to a brigade. This allows the ATKHB commander to cycle his companies into the fight until the mission is complete. The ATKHB is normally employed under brigade control. When a battalion task force is in heavy contact and receives attack helicopter support from brigade, the ATKHB is used to attack targets in designated engagement areas. The maneuver battalion will rarely receive aviation assets to solely support its tactical plan, but may normally be required to work closely with aviation units in support of a brigade or division scheme of maneuver. Working with the battalion task force commander, the ATKHB commander maneuvers his forces to attack. Coordination is made

by either the ATKHB commander or the attack helicopter company commander with aircraft actually on station. If at all possible, this coordination should be face to face. (See FMs 1-100 and 1-112.)

b. Coordination.

- (1) **Ground and air.** During the normal course of aviation support to the division, elements of the aviation brigade will use ground and air controlled by the battalion. To fully synchronize operations, ground and aviation commanders should coordinate:
 - Current enemy situation.
 - Friendly situation and location of friendly units.
 - The ground commander's mission and scheme of maneuver.
 - Fire control and restrictive fire control measures.
 - Suppression of enemy air defense weapons.
 - Available indirect fire support (and unit locations).
 - Target priority, firing positions, and engagement areas for the attack helicopters.
 - The low-level entry and exit routes to be used by the aviation unit.
 - Selection of holding areas and proposed attack positions for the attack helicopters.
 - Location of the aviation unit's FARP.
 - Visual or other signals or markers to be used.
 - Call signs and frequencies to be used.
- (2) **Air passage of lines.** When coordination for an air passage of lines is necessary, the exchange of information between the air and ground units should include the following elements.
 - (a) The disposition and scheme of maneuver of friendly forces (maneuver units, ADA, and artillery unit).
 - (b) The location of passage points along the FEBA or FLOT. Attack helicopters will use multiple passage points for cross-FLOT operations. All FEBA units must be aware of heavy aviation activity, forward and rearward, and positively identify friend from foe.

- (c) The estimated time of passage. This may be either a short period or extended over a few hours, depending on the time required to conduct a forward passage of lines to the engagement area, return through friendly elements to the FARP, and then re-cross friendly lines en route back to the battle area.
- (d) The type and, if available, the number of aircraft to make the passage. The number of helicopters maybe difficult to estimate because of maintenance, battle losses, or FARP rotation.

Section V. AIR DEFENSE SUPPORT

An effective system for the dissemination of timely early warning greatly enhances the effectiveness of both active and passive air defense measures.

6-16. PASSIVE AND ACTIVE AIR DEFENSE

- a. **Passive Measures.** Passive air defense measures consist of all the measures taken to preclude the enemy from locating the unit. Target detection and acquisition from high-performance aircraft is difficult. In most cases, enemy pilots must be able to see and identify a target in order to attack. The task force should follow certain guidelines.
 - (1) When stopped, occupy positions that offer natural cover and concealment, dig in, and camouflage vehicles that are exposed; when moving, travel by covered and concealed routes.
 - (2) Disperse vehicles as much as possible, to make detection and attack difficult.
 - (3) Wipe out track marks that lead to a position.
 - (4) If moving when an enemy aircraft attacks, disperse and seek cover and concealment.
 - (5) Do not fire on a hostile fixed-wing aircraft unless it has identified a friendly vehicle or location. Premature engagement will compromise friendly locations.
 - (6) Require air guards in each section or in each position.
 - (7) Establish an air warning system in the SOP; include both visual and audible signals.

- b. **Active Measures.** Air defense for the task force is provided by its organic individual and crew-served weapons, and by nonorganic supporting air defense artillery units. The firepower of the task force's machine guns, 25-mm guns, and small arms massed against an attacking aircraft is a formidable air defense system. TOWs and tank main guns can also be used against slow moving helicopters. Use of small arms against attacking aircraft is described in FM 44-8.

6-17. RELATIONSHIPS AND MISSIONS

- a. The brigade commander may retain all available ADA under his control, or assign a portion of the ADA to the task force with a support relationship such as DS or attached. Normal task force organization may include a section of Stingers and a platoon of air defense gun systems.
- b. The senior air defense officer functions as a special staff officer during the planning process. He provides his estimate and recommendations to the task force commander. ADA elements with a GS mission may, in many instances, provide incidental coverage over the task force area, and should be considered in the planning process.
- c. To properly employ air defense assets, the commander must —
- Assign tactical missions to the ADA element.
 - Establish priorities for air defense; for example, main effort, choke points, axes.
- d. The ADA unit leader positions his weapons as necessary to support the task force. The task force provides CSS to the attached ADA elements and coordinates with the ADA headquarters for the additional CSS equipment and personnel required for the ADA attached element.

6-18. SYSTEMS AND CHARACTERISTICS

This paragraph contains an overview of air defense weapons systems most often placed in support of the task force.

- a. **Stinger.** The Stinger man-portable air defense system (MAN-PADS) is used to counter high-performance, low-level ground attack aircraft, helicopters, and observation and transport aircraft. A Stinger section includes a headquarters element with a section chief and a driver and three to five Stinger crews. Each two-man Stinger crew has an M998 with six infrared homing

(heat-seeking) Stinger weapons in the basic load. The range of the stinger is in excess of 4,000 meters.

- b. **Vulcan.** The Vulcan system is used for forward area air defense against low altitude aircraft. Because its aerial range is only 1,200 meters, it is normally employed in conjunction with Stinger. Each Vulcan carries a four-man crew and two Stingers. The Vulcan's maximum rate of fire is 3,000 rounds per minute, but it only carries 1,100 rounds in the weapons and 1,000 rounds ready to load. Ammunition resupply for the four-squad Vulcan platoon is provided by a 5-ton cargo truck or M548. The platoon also has an M113 and M998.

6-19. WEAPONS CONTROL

- a. Air defense rules of engagement are directives that specify the circumstances under which an aircraft can be engaged. Weapons control status is established by higher headquarters. Stinger crew leaders and Vulcan squad leaders are responsible for deciding whether an aircraft is hostile or friendly. Weapons control status describes the relative degree of control exercised over air defense weapons:
 - **WEAPONS FREE.** May fire at any aircraft not positively identified as friendly (least restrictive).
 - **WEAPONS TIGHT.** May fire only at aircraft positively identified as hostile.
 - **WEAPONS HOLD.** Do not fire except in self-defense or in response to a formal order (most restrictive).
- b. Weapons control status is disseminated by the airspace management elements at division and corps. The task force commander has the authority to impose a more strict weapons control status than that dictated by higher headquarters; however, he may not go to a less restrictive status.

6-20. EARLY WARNING

- a. The early warning system for the division is standardized throughout the division and should be published in the TF SOP. Standard air defense warnings (alert postures) are
 - **RED** — Attack by aircraft or missiles is imminent or in progress.
 - **YELLOW** — Attack by aircraft or missiles is probable.
 - **WHITE** — Attack by aircraft or missiles is improbable.

- b. When ADA elements are in direct support or attached to the TF, they assist in early warning since they monitor the division early warning net. The senior air defense officer or NCO enters the TF command net to pass early warning information.
- c. Early warning for the task force may also be obtained over the brigade command and O&I nets. The air defense liaison officer at the brigade TOC monitors the division early warning net and relays information and early warning of enemy air activity in the brigade area.
- d. Early warning is immediately broadcast to task force subordinate elements by the main CP on the task force command net. It should include warning and direction of attack. The warning may be a simple statement or codeword to indicate an air attack. The direction of attack may be given as a cardinal direction, as a quadrant, or by using a clock system. Example: "Dynamite (the unit's codeword for air attack), ten o'clock."
- e. Early warning is also initiated by persons within the task force. The first person who observes a hostile aircraft must initiate the early warning by passing it over the TF command net. The warning must be passed in turn to higher and lower nets.
- f. Once the alert is terminated, that information is passed.
- g. If friendly aircraft are in the area, that information should also be passed.

6-21. EMPLOYMENT CONSIDERATIONS

- a. Determination of air avenues of approach is accomplished by the joint efforts of the S2, AD officer, and ALO and disseminated to subordinates. Primary characteristics of air avenues are:
 - Rotary and fixed-wing aircraft use terrain mask to avoid ADA fires and radar detection.
 - Overflight of friendly positions is avoided.
 - Major terrain features are used to assist in navigation.
- b. Threat attack helicopters with stand-off ATGM capabilities are employed in pairs. Synchronized with ground elements, they can be expected to attempt flanking attacks using concealed routes to concealed firing positions. The mobility of the attack helicopter threat increases the need for all-round security, passive air defense measures, and forward positioning of air defense weapons.
- c. Threat CAS capability includes smart munitions and other advanced ordnance loads. The threat's primary use of CAS is

against positions in depth, such as when the task force is in reserve. In such roles, the use of passive measures is of critical importance.

- d. The task force's employment of ADA support is based on the commander's air defense priorities. These are developed with the assistance of the ADA officer. These priorities change during the course of an operation. At task force level, priorities are based upon an analysis of criticality to mission accomplishment, vulnerability, and threat.
- e. ADA elements supporting the task force can be kept under the centralized control of the platoon leader or attached to company teams.
 - (1) Whenever possible, centralized control is favored because it allows a better coordination of ADA support.
 - (2) Attaching Stingers is appropriate in mobile operations to get Stinger coverage well forward and allow the Stinger gunners to move under armor protection. In a situation where there is a considerable threat from artillery, decentralized Stinger employment should be considered. A technique is to have the stinger gunner ride on the tank company's fire support vehicle (FSV) or on the mechanized infantry company's FSV or XO's vehicle.
- f. When employed under centralized control, the normal mission given to ADA elements is general support to the task force with priorities to a unit or tasks. ADA elements may protect critical areas as well as units. Examples are withdrawal and counter-attack routes in the defense or choke points in the attack. When the area of operation is small or the task force rate of movement is sufficiently slow, the ADA element may provide area coverage for the entire task force. When given the mission of providing such support, the ADA leader and the S3 coordinate the positioning of ADA elements with forward company teams or flank guards.
- g. Based on the commander's priorities, the AD leader attempts to satisfy as many of the following employment guidelines as possible —
 - Balanced fires.
 - Weighted coverage against the most likely approach.
 - Early engagement.
 - Defense in depth.

- Mutual support.
 - Overlapping fires.
- h. Infiltrating dismounted infantry is especially vulnerable to attack helicopters if discovered in open terrain. Dismounted Stinger gunners should accompany dismounted infantry elements when vulnerability and criticality point to such employment.
- i. ADA Class V immediate resupply should be carried in the task force combat trains. This can be on trucks provided from the ADA parent unit or on task force trucks.
- j. Vulcans can provide excellent suppressive and anti-infantry fires. The ground range of the Vulcan is 2,200 meters (direct fire) to 4,500 meters (indirect fire). However, their use in such roles must be weighed against the degradation of their primary mission. Limited basic loads normally restrict such use to critical situations. (Additional information on Vulcan/Stinger tactical employment is in FM 44-3 and FM 44-16.)

Section VI. ENGINEER SUPPORT

The brigade commander normally allocates at least an engineer platoon to the task force and augments it with additional assets depending on the task force mission.

6-22. CAPABILITIES

- a. Engineers are a combat multiplier. They provide skills and equipment necessary to assist the task force in accomplishing mobility, countermobility, and survivability tasks.
- (1) **Mobility** support seeks to improve movement of maneuver forces and critical supplies by reducing or eliminating obstacles, breaching minefield, and improving routes for maneuver and supply.
 - (2) **Countermobility** support involves obstacle construction to delay, canalize, disrupt, or kill the enemy. It also increases target acquisition time and, therefore, the effectiveness of direct and indirect fire weapons systems.
 - (3) **Survivability** support refers to the construction of vehicle fighting positions and dismounted fighting positions with overhead protection to reduce the effectiveness of enemy weapons.

- b. Combat engineers are primarily used for hand-emplacing and breaching obstacles, and augmenting the TF reconnaissance effort.
- c. Certain key equipment is employed by the combat engineers.
 - (1) The engineer platoon has organic mine detectors, demolition kits, carpenter and pioneer tool kits, and one 5-ton dump truck. The platoon will also have two M9 armored combat earthmovers (ACEs) with bulldozing capability and the mine clearing line charge (MICLIC). MICLIC is a trailer-mounted, rocket-projected explosive line charge which is towed within 50 feet of a minefield to clear a lane 5 to 8 meters wide and 100 meters long.
 - (2) Additional engineer equipment that can be requested from the engineer company includes:
 - (a) **Small emplacement excavator (SEE).** The SEE has a backhoe, bucket loader, and other attachments such as a handheld hydraulic rock drill, chain saw, and pavement breaker.
 - (b) **Armored vehicle launched bridge (AVLB).** The AVLB is a tank chassis modified to transport, launch, and retrieve a 60-foot span, Class 60 bridge. The bridge is capable of carrying military load classification (MLC) 60 track loads across a 17-meter gap and MLC 70 track loads across a 15-meter gap.
 - (c) **Combat engineer vehicle (CEV).** The CEV is a basic M60A1 tank with a hydraulically operated dozer blade, a 165-mm turret-mounted demolition gun, a retractable boom, and a winch. The gun provides direct fire support that can be used in obstacle reduction or against bunkers or buildings.
 - (d) **Ground-emplaced mine scattering system (GEMSS).** The GEMSS is trailer-mounted. Its 800 on-board mines have a built-in self-destruct capability. The antitank mine has a magnetic influence fuze. The antitank mine is activated by tripwires. For most antitank minefield, three 60-meter-wide belts separated by 50 to 100 meters of unmined area will be emplaced. A well-trained crew can emplace a 1,000-meter minefield in one hour.

6-23. EMPLOYMENT CONSIDERATIONS

Engineer assets may be controlled by the task force under the senior supporting engineer or may be attached to subordinate companies.

- a. Even when under task force control, the senior supporting engineer must coordinate the execution of engineer tasks, as well as movement and positioning of engineer elements with the company team in whose area they are employed.
- b. During mobile operations, the platoon is employed under task force control and positioned to be able to move quickly to likely obstacles. When accomplishing breaching operations in enemy contact, engineers are attached to the company team designated breaching force for the duration of that mission. Engineers may be assigned to scouts or reconnaissance patrols to assist in terrain and obstacle reconnaissance.
- c. While the engineers provide support to the task force, it provides support to the engineers. This support is in the form of security for engineer work parties, additional manpower, and CSS. The task force engineer with the S4 must develop and coordinate a plan with the supporting engineer's parent organization that ensures the supply of Class III, IV, V, and IX to support both engineer support elements and the supplies needed to accomplish engineer tasks. Some engineer equipment, such as bulldozers, will receive high maintenance priority in the defense.
- d. Engineer elements will frequently shift from supporting one company to another. Companies are given priority of equipment use for a specified period or for the construction of a specified number of fighting positions. The gaining company is responsible for locating the operator and guiding him to the new location.
- e. In the offense, engineers assist the task force's maneuver over existing terrain and obstacles. The engineers assist in —
 - Crossing gaps.
 - Bridging rivers.
 - Breaching or constructing bypasses around minefield, fortified positions, and other obstacles.
 - Emplacing minefield on exposed flanks.
 - Preparing positions for overwatch.
 - Constructing and maintaining combat roads and trailers.
- f. The engineer role in the defense is to use the terrain to enhance the mobility and survivability of the task force while simultaneously impairing the mobility of the enemy. These actions allow the task force to shape the battlefield to better target the enemy and to employ its forces to fight and defeat a numerically larger force. In the defense, engineers are a critical asset. The commander must decide whether engineers are to build obstacles,

prepare protective positions, or cut routes between battle positions. It is essential that tasks for special equipment such as bulldozers and bucketloaders be prioritized. Engineers must begin their work for the task force as soon as the defensive mission is received.

6-24. ENGINEERS FIGHTING AS INFANTRY

Engineers have a secondary mission of fighting as infantry. However, the decision to employ an engineer unit as infantry is made only in critical circumstances. This does not mean that engineers will never fight as infantry. In fact, engineers may have to fight as infantry in the normal execution of their mission. Engineers fighting as infantry do not have organic combat support, and they will require additional support in the form of mortars, antitank assets, and artillery.

Section VII. NUCLEAR, BIOLOGICAL, AND CHEMICAL SUPPORT

While the support discussed may not always be task organized down to task force level, the task force commander must know what is available so that he can request it should the need arise.

6-25. CHEMICAL COMPANY

- a. The chemical company provides the division with four decontamination platoons, a reconnaissance platoon, and one smoke platoon. Each decontamination platoon is equipped with three M12A1 power-driven decontaminating apparatus (PDDA) mounted on 5-ton trucks. The smoke platoon is equipped with 12 mechanical smoke generators mounted on six M113's. Additionally, there are two organic lightweight decontamination systems per battalion task force, with the support platoon's chemical specialist as the operator.
- b. Every combat battalion has a chemical officer and NCO assigned to the battalion S3 section, and each company has a chemical NCO. Their duties are described in FM 3-100.
- c. During offensive operations, a decontamination platoon may be attached to or placed in direct support of a brigade. Sometimes more than one platoon supports a brigade, particularly when the brigade is making a main attack.
- d. During withdrawal operations, NBC decontamination platoons operate either under division control or in DS to brigades.

Decontamination squads are used in area support roles. They operate in an assigned sector and support all units in that sector. They locate potential decontamination sites and direct contaminated units to those sites.

6-26. NBC RECONNAISSANCE PLATOON

One NBC reconnaissance platoon is organic to the division chemical company. When persistent contaminants are expected, division may attach an NBC reconnaissance element to a maneuver brigade.

- a. In the offense, a reconnaissance squad may move with the leading battalion task force along a route where the threat of contamination is greatest.
- b. In the defense, reconnaissance squads operating in the main battle area are used to determine the extent of contamination and to locate sites for deliberate decontamination.

6-27. SMOKE EMPLOYMENT

Smoke can degrade effectiveness of both personnel and weapons systems. Smoke can have both psychological and physiological effects on personnel, and it may defeat or degrade optical or electro-optical sights and target acquisition devices. When improperly used, smoke can also attract the attention of the enemy. The task force commander must consider using smoke to aid his scheme of maneuver, avoid developing a pattern of using smoke, and plan to counter enemy use of smoke.

- a. **Purpose.** During offensive operations, smoke is used to conceal units and individual weapon systems. The commander can maneuver behind a smoke screen and deceive the enemy about his strength and position. Smoke can also blind enemy observers and hinder enemy target acquisition. This not only lessens the effectiveness of sighting devices but also hinders the use of antitank optically guided missiles.
 - (1) During defensive operations, smoke can be used to separate and isolate attacking echelons. This can create gaps in enemy formations and disrupt planned movements. Smoke is also used to slow and blind individual units and weapon systems. This may force enemy infantry to dismount from mechanized vehicles. Smoke may also be used to conceal occupation of defensive positions.
 - (2) Smoke helps to disorient and confuse the enemy. To be effective, it must be employed correctly.

- (a) Smoke is useless unless employed in quantity. A smoke cloud must be large and dense enough to meet the needs of the mission.
 - (b) Smoke effectiveness depends on weather conditions and wind direction and speed. If the wind is strong or in the wrong direction, it may preclude an effective smoke screen. A good time to employ smoke is during an early morning calm, before the sun heats the earth and hot air begins to rise. These early-morning conditions will cause smoke to linger near the ground.
 - (c) Smoke is valuable during limited visibility; smoke adversely affects passive and infrared night vision devices (NVDs). Combat operations become even more difficult when smoke is added to darkness and fog.
- (3) The S3 has staff responsibility for integrating smoke and other obscurants into the task force's operation plan. In doing so, he coordinates with higher headquarters, the fire support coordinator, the chemical officer, and the battalion S2. When planning the use of smoke, the degradation of enemy combat effectiveness must be weighed against possible negative effects on friendly command and control, target acquisition, and the potential for signaling the intent or location of the operation to the enemy.
- b. **Types.** The battalion employs four general applications for smoke on the battlefield: obscuration, screening, marking and signaling, and deception.
- (1) **Obscuration.** Smoke is placed on or near the enemy's positions to interfere with his observation and fire and navigation.
 - (2) **Screening.** Smoke is employed within areas of friendly operation, or in areas between friendly and enemy forces, to degrade enemy ground and aerial observation and fire. Screening is primarily intended to conceal friendly forces.
 - (3) **Marking and signaling.** Smoke is employed to begin or end actions on the battlefield and to mark reference points, targets, and unit locations. Smoke used for marking and signaling usually consists of colored or WP smoke.
 - (4) **Deception.** Smoke is used in coordination with other actions to create the illusion that some tactically significant event is occurring, in order to confuse or mislead the enemy. Some techniques are to use deceptive smoke in dummy river crossings, withdrawals, or air assault operations. Generally,

deceptive smoke is used in conjunction with other deceptive measures such as sound or electronic deception.

- c. **Sources.** The task force normally has ready access to six systems that can produce smoke for tactical operations. Because these systems are designed for different purposes, their use on the battlefield varies with the operation or situation. Smoke generator units may be attached to provide support to task force operations.
- (1) Mortars can create a high volume of smoke at midranges in a specific area. They are, in fact, the most rapid and effective means of indirect smoke delivery available to the maneuver commander. They are also used for spotting, marking, and signaling. The mortar platoon's basic load of smoke is established to support the operation.
 - (2) Field artillery cannons are used primarily to place two types of smoke-producing munitions rapidly on distant targets: white phosphorus (WP) and hexachlorethane (HC). Because of the limited number of smoke rounds in the FA basic load, use of artillery smoke must be carefully planned.
 - (3) Smoke pots produce large volumes of white or grayish-white smoke for extended periods. They are the unit commander's primary means of producing small area smoke screens that last 10 to 15 minutes. Pots may also be used to place smoke on water, since they are the only smoke-producing systems that float. Employment techniques include the following.
 - (a) Smoke pots can be ignited singly by using the means of ignition supplied with each pot. The M1 smoke pot is designed for manual ignition, but it may be modified for electric ignition. The ABC-M5 smoke pot has an integral electric ignition device and a friction igniter, and can be ignited manually or electrically. Floating smoke pots are ignited by fuzes. Two of the floating smoke pots, the AN-M7 and the AN-M7A1, can be fitted with M209 electric smoke pot fuzes for ignition. Circuits and connections for electric ignition are the same as for demolitions (see FM 5-25).
 - (b) When a number of M1 or ABS-M5 smoke pots at different locations must be ignited simultaneously, they can be prepared for electric ignition and connected into a firing circuit as described in FM 5-25. The AN-M7 and AN-M7A1 floating smoke pots can also be ignited electrically in multiples when the M209 fuze is used.
 - (c) A number of M1 or ABC-M5 smoke pots can be arranged to ignite in succession. This provides smoke for a longer

period than a single pot. For chain ignition, the pots can be placed in stacks and the top pot in the stack ignited; or they can be laid on their sides end to end and the pot with the exposed igniting device ignited (see Figures 6-4 and 6-5). Before stacking, the outer covers must be removed from all pots to expose igniting devices. Vertically stacked M1 smoke pots must be supported. The ABC-M5 smoke pot is especially designed for vertical stacking.

- (d) When the situation requires concealing the glare from a burning smoke pot, improvise a shield. The shield must permit the smoke to escape and conceal the glare of the pot. The smoke pot can be placed under a 55-gallon drum, laid in a covered trench, or shielded by other field expedients. Neither the drum nor the trench will completely screen the light from the burning pots. Further, a smoke pot enclosed in a shield produces slightly less smoke than an unshielded pot. Compensate by using more smoke pots.

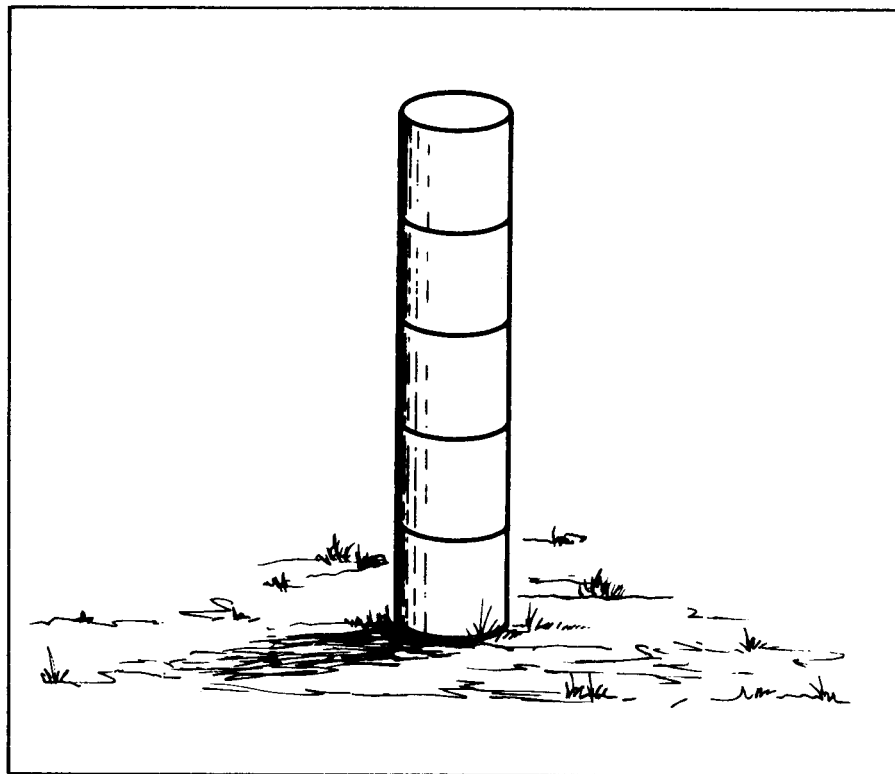

Figure 6-4. Smoke pots stacked vertically.

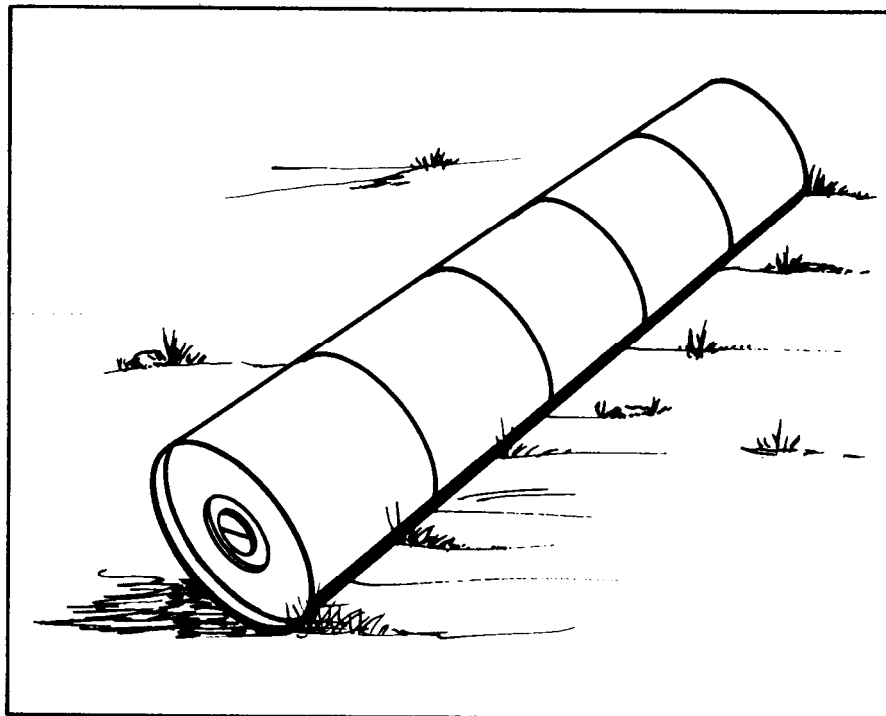

Figure 6-5. Smoke pots laid end to end.

- (4) Smoke grenades are manufactured in two varieties, white smoke and colored smoke. White smoke grenades are most often used to cover or screen individual vehicles while colored smoke grenades are used to mark or spot specific positions. Smoke grenades should not be used to screen units larger than one or two squads.
- (5) Vehicle smoke grenade launchers generate a limited amount of smoke rapidly to conceal or screen individual vehicles from enemy gunners. The vehicle commander usually launches grenades, as soon as he is fired upon.
- (6) The vehicle engine exhaust smoke system (VEESS) is currently fielded on M1 and M60A3 tanks, the M2 and M3 fighting vehicles, and the M88A1 recovery vehicle. The system injects diesel fuel into the engine exhaust system to produce smoke. The system consumes fuel at a rate of one gallon per minute of operation.

d. Planning Considerations.

- (1) The use of smoke should be planned for every operation and for all conditions including day and night. What is important

is to plan for all eventualities and have smoke available, rather than attempt to react to situations without being prepared. A major consideration when planning and employing smoke is that smoke is not an unlimited resource. It should be used when needed and not employed indiscriminately.

- (2) To put smoke where it is wanted and to keep it there, smoke operations must be planned, controlled, and adjusted much like artillery fire. In addition, the commander must ensure that his use of smoke does not adversely affect an adjacent unit. Smoke affects vehicles equipped with thermal sights; they can still engage through smoke, but with limited capability. Smoke also degrades the capabilities of laser rangefinders.
- (3) Smoke limits maneuver capability. Because smoke restricts observation of surroundings, it reduces a driver's ability to sense direction, location, and his relationship to other vehicles. Dismounted guides may be needed to guide combat vehicles through dense smoke, especially when obstacles are encountered or suspected.
- (4) Smoke should not be routinely placed on suspected enemy positions. A more efficient use of smoke would be to place it close to the enemy but between friendly and suspected enemy positions; doing so increases the chances of obscuration.

e. Offensive Use of Smoke.

- (1) During offensive operations, smoke is normally used to screen the attacker. Five basic techniques for unit smoke operations during an offense are discussed below. There will probably be a chance to employ a number of these techniques during each operation. It may be necessary to develop variations to these techniques to satisfy different mission requirements. Deception is the key. The longer the deception, the greater the chances for success in an operation.
 - (a) **Blind enemy observers.** This technique is effective when conducting a movement to contact or when enemy contact is likely. There are two ways to employ this technique using mortar and field artillery as a means of smoke delivery. One way is to place smoke directly on all known or suspected enemy observer positions. The other way is to produce a smoke screen between known or suspected enemy observer positions and the unit. Either way, the smoke cloud must be maintained until the unit reaches its objective or passes the danger area.

- (b) **Obscure vehicles from enemy direct fire gunners.** This technique is used by combat vehicle commanders to degrade the ability of enemy antitank guided missile gunners.
- (c) **Conceal a bypass.** There are two ways to employ this technique. One way is to screen the bypassing unit while it is moving around the enemy. The second way is to make the enemy believe he is the object of an attack by placing smoke directly on him.
- (d) **Screen an assault.** This technique is used to cover a unit while it is attacking. It is employed by having elements on one flank produce a lateral smoke screen.
- (e) **Cover a breaching operation.** This technique is employed by developing two simultaneous smoke clouds, which are placed directly on the enemy and between the enemy position and the breaching force. It is essential to maintain continuous smoke in both areas, since minefield are normally covered by direct and indirect fire.

(2) Smoke may also be used during offensive operations to —

- Disorient the enemy in his defensive positions.
- Defeat infrared tracking systems.
- Screen the attacker's flank.
- Screen the location of passage points of lines.
- Create a deception.
- Aid in securing water crossings, beachheads, or other amphibious assaults.
- Mark or silhouette enemy positions (on the position).
- Mark friendly positions (away from the position, if possible).

f. Defensive Use of Smoke.

- (1) There are three basic techniques for battalion smoke operations during defensive operations. It may be necessary to develop variations to these techniques or to use a number of them in a single operation.
 - (a) **Slow the advance of attacking forces.** This technique causes the attacker to slow the momentum of his attack.

- (b) **Separate and isolate attacking echelons.** This technique develops a lateral smoke screen between two echelons. The smoke prevents the second echelon from seeing the first echelon fight and from providing it effective overwatch. The smoke also slows the second echelon.
- (c) **Cover movement.** Smoke is produced in front of the battle position so combat vehicles can move without being observed. As smoke dissipates, a new smoke screen is established between the enemy and any displacing vehicles.

(2) Smoke may also be used during defensive operations to —

- Cause confusion in enemy formations.
- Assist in disengagement.
- Obscure enemy observation posts.
- Degrade the enemy's ability to adjust fires.
- Isolate elements of enemy forces for concentration of fires.
- Conceal a concentration of forces.
- Obscure enemy direct fire systems.
- Degrade the performance of precision-guided munitions.
- Mark enemy positions.
- Mark friendly positions.
- Screen a counterattack.
- Assist in deception.

g. **Threat Countermeasures to Smoke Operations.** Threat forces train extensively to overcome the operational difficulties encountered with fighting in a smoke environment. They categorize their countermeasures into three areas: tactics against enemy defensive use of smoke, tactics against enemy offensive use of smoke, and electro-optical devices that can acquire targets in a smoke environment.

- (1) **Threat tactics against defensive use of smoke.** When US forces employ smoke to conceal friendly positions or to confuse the attackers, the Threat relies on maintaining momentum as a means of survival. The Threat believes that battlefield smoke favors the attacking elements; hence,

Threat forces train extensively in a smoke environment so that a rapid rate of advance can be maintained.

- (2) **Threat tactics against offensive use of smoke.** Training for defense in a smoke environment calls for withdrawing from the area of heaviest smoke concentration and attempting to flank the enemy and engage him in a crossfire. Where retention of terrain is required, the Threat may reinforce units within the smoke area with second-echelon or reserve elements.
- (3) **Threat electro-optical devices.** Realizing the importance of smoke as an optical or electro-optical countermeasure, the Threat has developed a variety of sophisticated battlefield surveillance systems. Threat forces are known to have active night vision devices (with near-infrared light sources) and passive image intensifiers.

Section VIII. INTELLIGENCE AND ELECTRONIC WARFARE SUPPORT

In order for the task force commander to make the most efficient use of his combat power, he must have information concerning enemy dispositions and probable course(s) of action. The primary means to obtain information in the task force area are subordinate maneuver companies, patrols, scouts, OPs, and FISTs. The task force S2 is responsible for coordination, information collection and dissemination by planning use of task force reconnaissance and surveillance (R&S) resources. He also requests support from higher headquarters (human intelligence [HUMINT], signal intelligence [SIGINT] including electronic intelligence [ELINT], and overhead photography) to fill the commander's intelligence requirements. Additionally, immediate requests for air coverage (Army and/or Air Force) may be requested via S3 Air's or TACP's communications channels. Other timely sources of intelligence information include forward and adjacent ground maneuver and aviation units, and the artillery nets monitored by the FSE.

6-28. INTERROGATION TEAM

Interrogation teams are normally GS to the division, or DS to the brigade. If an interrogation team is placed in direct support of a task force for a specific mission and time, the commander positions it near the prisoner of war (PW) collection point in the combat trains.

6-29. GROUND SURVEILLANCE RADAR

GSR provides a highly mobile, near all-weather, 24-hour capability (night and poor daylight visibility) for battlefield surveillance. One or two GSR teams may be attached to a task force.

- a. As a rule, only GSR teams are provided to the task force. Teams are attached to the task force and employed by the battalion S2. Combat information collected by each team is passed to the battalion S2, who analyzes and disseminates it to the commander, S3, FSE, and subordinate units within the task force.
- b. GSR equipment can be either vehicle-mounted or ground-mounted, and it complements other combat surveillance and target acquisition means in the battalion. Its employment is coordinated with the employment of patrols and observation posts, and with infrared and other sensory devices.
- c. The primary advantage of radar is its ability to detect objects and provide accurate target locations when other surveillance means cannot. Radar is used primarily for operations during limited visibility (darkness, haze, fog, or smoke).
- d. Radar can penetrate light camouflage, smoke, haze, light rain, light snow, darkness, and light foliage. Heavy rain or snow restricts radar detection capabilities; however, a well-trained operator can minimize these effects. Radar is limited to line-of-sight.
- e. Ground surveillance radar is ineffective against air targets unless the air target is flying close to the ground, because it is designed to detect only moving targets in the presence of a background.
- f. The radar is vulnerable to direction finding and jamming by enemy electronic combat and other deception means.
- g. Ground surveillance radar may be employed in all types of tactical operations. The two types of surveillance missions employed by radar personnel are search and monitor. The radar section is capable of performing a variety of tasks, including —
 - (1) Searching avenues of approach, possible enemy attack positions, assembly areas, or other sectors or areas on a time schedule, at random, or continuously to report location, size composition, and nature of enemy activity.
 - (2) Monitoring point targets, such as bridges, defiles, or road junctions; and reporting quantity, type, and direction of movement of targets through the point.

- (3) Monitoring and searching final protective fire areas or barrage locations to permit timely firing.
 - (4) Extending the observation capabilities of patrols by enabling them to survey distant points or areas of special interest.
 - (5) Assisting the visual observation of units during daylight by making initial detection of partially obscured (hazy) targets at long ranges.
 - (6) Assisting in the movement control of units during limited visibility operations.
 - (7) Increasing the effectiveness of fire support. When targets have been detected with reasonable certainty by radar, the fire support means may immediately take the target under fire. Well-trained radar operators can estimate the density of enemy activity in a given area and the rate of enemy movement, thereby assisting in weapons selection.
 - (8) Determining rate of movement of a target by plotting the location of the target at two known points and the time it took the target to move from one point to the other.
- h. In order for radar teams to provide good coverage, they must understand the mission, scheme of maneuver of the supported unit, and the most likely targets expected in the area of operations. Teams must be assigned a specific sector of surveillance, the desired degree of overlapping coverage, and frequency of coverage. To prevent detection by enemy direction finding equipment and enemy electronic countermeasures, operators turn on equipment only when needed.
 - i. The battalion S2 advises the commander on where and how ground surveillance radar can best be employed to support the scheme of maneuver. Once this has been determined, the S2 assigns areas and methods of search and locations when GSR is retained in support of the battalion. Each team reports information to the supported unit or S2. Additionally, the S2 ensures that GSR positioning and coverages are integrated with other reconnaissance and surveillance means (patrols, scouts, OPs, TOW sights, NVDs) to ensure full coverage of the task force area of operations and interest.
 - j. The S2 directs the general positioning of the radars; the exact location is selected by the section leader or senior operator and is reported after the radars are in place. Forward slopes of radar sites must be covered by other observation means, because the slopes will be dead space to the radar. GSR teams displace only on order of the GSR section leader or supported unit commander.

- k. When time permits, alternative and supplementary positions are selected and prepared. Radar surveillance cards are prepared by the senior radar operator, who gives a copy to the battalion S2.
- l. Radar should be kept as far forward as the tactical situation and terrain will permit. Displacement should not be delayed arbitrarily until the radar teams can no longer provide effective support. Timely displacement will enable forward units to maintain fire on withdrawing enemy units or to detect enemy activity indicating a counterattack. When feasible, teams displace by bounds.
- m. Highly mobile, fast-moving offensive operations may preclude the continuous and effective use of radar. However, many of the possible uses are discussed below.
 - (1) **Movement to contact.** During the movement to contact, radar may be employed with reconnaissance and security elements on an exposed flank or to provide additional observation and security. To provide continuous flank surveillance, it may be necessary to employ radars in pairs and move them by bounds.
 - (2) **Penetration.** Radar may be employed profitably in a penetration by locating enemy defenses before the attack. This information is used by the commander to avoid enemy strengths and capitalize on enemy weaknesses. Radar teams may locate enemy activity to facilitate use of preparatory fire, and may survey enemy positions to establish whether there is any reinforcement, shifting, or withdrawal of enemy units just before the attack.
 - Once enemy contact has been established, radar may be used to provide surveillance forward of the line of contact or on an exposed flank. It may be positioned to provide surveillance over critical areas on avenues of approach during the attack.
 - During limited visibility, radar may be employed to vector or guide friendly attacking elements. It may be used in tracing the movement of forward friendly units to establish and confirm their specific location at any given time and to coordinate supporting fire with the advance of friendly elements.
 - (3) **Envelopment.** In the envelopment, radar may be able to detect large gaps or assailable flanks. It may be possible to employ the radar with security elements of the enveloping force to provide early warning of enemy activity.

- (4) **Consolidation and reorganization.** On order, radar teams displace to positions previously selected by a visual or map reconnaissance. During the consolidation and reorganization, primary emphasis is on immediately placing the equipment in operation. Thereafter, positions are improved and equipment is dug in and camouflaged as the situation permits. Since the radar teams on the objective will be surveying the area beyond the objective, they must be informed of friendly patrols and other elements sent forward to maintain contact with the enemy.
 - (5) **Exploitation or pursuit.** In the exploitation or pursuit, radar teams are employed essentially as they are in the movement to contact. Additionally, radar teams attached to an enveloping force may be sited to locate withdrawing enemy elements or to assist in identifying friendly units during linkups.
 - (6) **River crossing operations.** Radars are used in a river crossing as in normal offensive operations. When smoke is used by friendly forces engaged in a river crossing, radar may be used to detect enemy troop activity on the far bank including withdrawal, reinforcement, or shifting of units.
 - (7) **Infiltration.** When gaps in enemy defenses have been located, attacking elements may infiltrate through the enemy position. Radar teams may be employed effectively in conjunction with infiltration by surveying infiltrating lanes for enemy activity and determining the progress of infiltrating units. Short-range radar teams may be employed with infiltrating units in the enemy rear area. Infiltrating elements may use a radar team to enable them to locate enemy activity and avoid discovery. However, radar emissions may compromise the location of friendly units. The determination of whether radar teams should be employed by an infiltrating element depends on the urgency of obtaining information of the enemy in the area, as opposed to the need for avoiding discovery. If radar is employed with infiltrating elements, it may also be used to assist linkup with attacking forces.
- n. GSR is used in both the covering force area and the main battle area. GSR assets are placed in general support of the task force to screen avenues of approach and gaps between company teams.

CHAPTER 7

COMBAT SERVICE SUPPORT

The combat service support mission to sustain the combat power of the task force under dispersed and sometimes isolated conditions is increasingly critical to success on the battlefield. Combat service support is performed as far forward as the tactical situation permits. Weapons and systems are armed, fueled, fixed, and manned in forward positions to reduce the time required to return them to combat. The task force commander, mainly through his XO, S4, and S1, anticipates and plans requirements for CSS and employs his service support assets to ensure accomplishment of present and future missions. When possible, higher headquarters preconfigures and delivers materials before requests are generated ("push packages"), especially in the bulk resupply of Classes III, IV, and V.

CONTENTS	
PARAGRAPH	PAGE
Section I. CSS FUNCTIONS AND ORGANIZATION	7-2
7-1 Overview	7-2
7-2 S1 Section	7-4
7-3 Medical Platoon	7-5
7-4 S4 Section	7-5
7-5 Support Platoon	7-6
7-6 Maintenance Platoon	7-6
Section II. PLANNING	7-7
7-7 Principles	7-7
7-8 Support of Combat Operations	7-8
7-9 Support of the Offense	7-8
7-10 Support of the Defense	7-10
7-11 Continuous Support	7-10
7-12 Task Force Logistics Estimate	7-11
Section III. OPERATIONS	7-11
7-13 Task Force Trains	7-12
7-14 LOGPAC Operations	7-14
7-15 CSS for Cross-Attachments	7-18
7-16 Trains Security	7-22
7-17 Command and Control	7-22
7-18 Communications	7-23
Section IV. SUPPLY	7-23
7-19 Supply Operations	7-24
7-20 Classes of Supply	7-24
7-21 Support of Night Operations	7-27

PARAGRAPH	PAGE
Section V. MAINTENANCE	7-28
7-22 Maintenance Terms	7-28
7-23 Categories of Maintenance	7-29
7-24 Maintenance Forward	7-29
7-25 Maintenance Concepts	7-30
7-26 Maintenance Operations at Night	7-33
Section VI. FIELD SERVICES	7-33
7-27 Mortuary Affairs	7-33
7-28 Clothing Exchange and Bath	7-34
7-29 Salvage	7-34
7-30 Laundry and Renovation	7-34
7-31 Airdrop/Airlift	7-34
Section VII. PERSONNEL AND HEALTH SERVICES SUPPORT	7-35
7-32 Personnel and Administrative Services	7-35
7-33 Chaplain Activities	7-36
7-34 Legal Services	7-36
7-35 Finance Services	7-36
7-36 Public Affairs	7-37
7-37 Postal Services	7-37
7-38 Prisoners of War	7-37
* 7-39 Health Service Support	7-37
Section VIII. RECONSTITUTION	7-40
7-40 Reorganization	7-41
7-41 Regeneration	7-41

Section I. CSS FUNCTIONS AND ORGANIZATION

The burden of CSS is removed from the company team commander, as much as possible, and placed under control of the task force. The company team commander concentrates on fighting his unit to accomplish the tactical mission. The CSS responsibility at company team level is mainly to report and request requirements, and to ensure that CSS is properly executed once it arrives in the team's area.

7-1. OVERVIEW

- a. The task force commander ensures that CSS is provided, not only for his organic and attached elements, but the task force commander ensures such for any OPCON.

or supporting units. The task force provides mission-essential CSS to a supporting unit. The S4 coordinates other CSS for the supporting unit, and verifies who is to provide this CSS and how it is to be requested. When a large attachment joins the task force, the attachment should bring an appropriate slice of CSS assets from its parent unit. These assets are controlled by the task force S4. The attached unit leader must coordinate with the task force S1 and furnish him with a copy of his unit battle roster. Thereafter, the attached unit submits reports and requests resupply according to the task force SOP.

- b. The task force combat trains CP is the focal point of combat service support for the unit. The combat trains CP, under the supervision of the S4, anticipates, requests, coordinates, and supervises execution of combat service support.
- c. The three categories of CSS are logistics support, personnel service support, and health services support.
 - (1) The four functional areas of task force logistics are—
 - Supply.
 - Transportation.
 - Maintenance.
 - Field services, which includes graves registration, clothing exchange, bath, salvage, laundry, textile renovation, airdrop and airlift, and bakery.
 - (2) Personnel service support includes a variety of functions that support a commander's ability to accomplish his mission and contribute to the welfare and morale of the soldier. Some major CSS personnel service functions are—
 - **Personnel and administration services**, which includes strength and personnel accountability, replacement operations, casualty reporting, awards and decorations, and personnel management.
 - **Chaplain activities**, which includes conduct of services, personal and religious counseling, and pastoral care.
 - Legal services.
 - Finance services.
 - Public affairs.
 - Postal services.
 - Enemy prisoner of war (EPW) support.

- (3) Health services support includes treatment and evacuation, medical supply support, and preventive medicine.
- d. The task force receives service support from various elements within and outside the task force.
- (1) **Within the task force.** The XO, assisted by the command sergeant major, is responsible for coordinating all CSS in the task force. The S4 is responsible for the logistical support of the task force and for preparing paragraph 4 of the OPORD. He is assisted by the S4 section and the support platoon. The S1 is responsible for personnel service support within the battalion and he coordinates the actions of the medical platoon. To assist him in this effort, he has a personnel and administration center (PAC). Maintenance support is the responsibility of the battalion maintenance officer (BMO), who directs the activities of the maintenance platoon.
 - (2) **Outside the task force.** The principal source of external support to the task force is the forward support battalion (FSB). It is organized with a headquarters and headquarters detachment, a supply company, a maintenance company, and a medical company to provide support to a maneuver brigade. Additional support can be provided by the main support battalion (MSB) of the division support command (DISCOM).

7-2. S1 SECTION

The S1 section is responsible for personnel services and the general administration of the task force. The S1 is assisted by the PAC supervisor and the personnel staff NCO (PSNCO). The S1 section has personnel at both the combat trains CP and the field trains. The S1 and his staff in the combat trains CP primarily perform the critical tasks of strength accountability and casualty reporting as well as command post functions. The S1 personnel in the field trains perform replacement operations, administrative services, personnel actions, legal services, and finance services. The S1 also has primary staff responsibility for EPW operations and medical planning. He coordinates with the S2 for interrogation of prisoners and the S4 for processing captured equipment and transportation requirements. The S1 coordinates with the medical platoon leader to ensure that patient treatment and evacuation is planned and coordinated throughout the task force area.

7-3. MEDICAL PLATOON

- a. The medical platoon sorts, treats, and evacuates casualties, or returns them to duty. It stocks medical supplies for the task force and provides all Class VIII support. It is also responsible for maintaining and evacuating battalion medical equipment. The medical platoon's survivability and mobility are increased by the use of armored evacuation vehicles and aid stations.
- b. The medical platoon leader (a physician), with the aid of a physician's assistant (PA), operates the battalion aid station. The medical operations officer, a medical service corps officer, coordinates the operations, administration, and logistics of the medical platoon. This includes coordinating patient evacuation to the supporting medical company and providing support to company teams.

7-4. S4 SECTION

- a. The S4 section is responsible for supply, transportation, and field service functions. It coordinates requisition and distribution of supplies to company supply sections and turns in captured supplies and equipment as directed. Personnel in the section are in the field trains and the combat trains CP. They are cross-trained with personnel of the S1 section in critical tasks to permit continuous operations. The S4 section is supervised by the S4, who is assisted by the battalion supply sergeant.
- b. In combat, the S4 concentrates on seven classes of supply: Classes I, II, III, IV, V, VII, and IX. The support platoon leader, working with the S4 and HHC commander, coordinates the requisition, receipt, preparation, and delivery of Classes I, III, and V. The supply section coordinates the requisition, receipt, and delivery of Classes II, IV, VII, and IX.
- c. The S4 section and the support platoon are responsible for obtaining water and maps. Using task force transportation, water is obtained from the water supply point in or near the BSA or from forward sources tested and approved by the medical platoon leader. Maps are stocked by the supply and service company of the main support battalion, and they are requested through the supply company of the forward support battalion. The S2 is responsible for distributing maps as required. Classified maps are obtained through G2 channels.

7-5. SUPPORT PLATOON

- a. The support platoon has a headquarters section, a transportation section which includes a decontamination specialist, and mess sections. The transportation section is organized and equipped to transport fuel, ammunition, and supplies to the companies. The section normally transports a portion of the unit basic load of ammunition plus fuels and lubricants. The transportation section has a POL vehicle supervisor and, in armor battalions, an ammunition sergeant. It also has drivers assigned to operate the section's cargo vehicles. The mess section is organized and equipped to prepare meals for all elements of the task force. The support platoon also has the task force decontamination vehicle and operator to assist in unit decontamination.
- b. Although the support platoon leader works for the S4, he is under the supervision of the HHC commander in the field trains. The platoon leader is assisted by the support platoon sergeant, who is also the truck master of the transportation section.

7-6. MAINTENANCE PLATOON

- a. The maintenance platoon performs unit maintenance on all task force equipment except COMSEC and medical equipment. The platoon leader is the battalion maintenance officer. He is assisted by the maintenance technician and the battalion motor sergeant.
- b. In armor and mechanized infantry battalions, all organizational maintenance assets, including communication-electronics equipment maintenance, are consolidated in the maintenance platoon. The responsibility for operator and crew maintenance, however, remains with the companies.
- c. The administration section maintains Class IX (repair parts) and The Army Maintenance Management Systems (TAMMS) records. The prescribed load list (PLL) stocks are maintained for each company at the UMCP and managed by the administration section's PLL clerks. To facilitate rapid repair, selected high usage PLL items may be on the tracked vehicles supporting a company team.
- d. The recovery support section provides limited welding, metalworking, and backup recovery support to the maintenance teams.
- e. The maintenance services section provides maintenance support to the rear elements of the task force, plus backup support to company maintenance teams.

- f. Company maintenance teams provide maintenance support to each of the maneuver companies. This support includes automotive, turret, and communications-electronics maintenance, as well as recovery.
- g. Based on the weapons systems within a company team, maintenance teams are task organized by the BMO. Insofar as possible, a maintenance team will habitually support the same company. When tracked vehicles from the maintenance team are positioned forward of the UMCP, the company commander establishes priorities of work and positions the team (usually accomplished through the unit 1SG). When a company is detached from the battalion, the BMO detaches a supporting maintenance package that includes the personnel, tools, test equipment, and PLL stocks necessary to support the company.

Section II. PLANNING

CSS planning is conducted to ensure support during all phases of an operation. The CSS plan is developed concurrently with the tactical plan. Supporting CSS plans areas detailed as planning time permits. Using SOPs and planning for contingencies will greatly assist the CSS staff officer in the planning efforts. Task force orders address only deviations from the routine planning priorities established in the SOP.

7-7. PRINCIPLES

- a. CSS functions are anticipative in nature and are performed as far forward as the tactical situation permits. Support must be continuous, using immediately available assets. Ammunition, fuels, parts, end items, maintenance personnel, and replacements are "pushed" forward to the combat trains, unit maintenance collection point, and logistical release points (LRPs).
- b. CSS planning is a continuous function. Coordination among tactical planners and those planning combat support and CSS is essential and addresses all factors that can have a significant effect on the tactical mission.
- c. CSS staff officers and commanders must act rather than react to support requirements. Personal involvement, remaining abreast of the tactical situation, and on-the-scene appraisal of the situation by CSS personnel is critical to mission accomplishment.

7-8. SUPPORT OF COMBAT OPERATIONS

- a. To ensure effective support, CSS operators and planners must understand the commander's tactical plans and intent. They must know—
 - **What** each of the supported elements will be doing.
 - **When** they will do it.
 - **How** they will do it.
- b. After analyzing the concept of operations, CSS planners must be able to accurately predict support requirements. They determine—
 - What **type** of support is required.
 - What **quantities** of support are required.
 - The **priority** of support, by type and unit.
- c. Using the requirements, support capabilities are assessed:
 - **What** CSS resources are available (organic, lateral, and higher headquarters).
 - **Where** the CSS resources are.
 - **When** CSS resources can be available to the maneuver units.
 - **How** they can be made available.
- d. Based on this analysis, CSS plans are developed that apply resources against requirements. See Appendix B and FM 101-10-1.

7-9. SUPPORT OF THE OFFENSE

- a. If offensive momentum is not maintained, the enemy may recover from the shock of the first assault, gain the initiative, and mount a successful counterattack. Therefore, the CSS priority must be to maintain the momentum of the attack.
- b. A successful attack may develop into an exploitation or a pursuit, and CSS planners must be flexible enough to support either type of operation. The following techniques and considerations apply to CSS offensive planning.
 - (1) Position essential CSS assets, such as ammunition, POL, and maintenance, well forward in the combat trains, and ensure that basic loads remain replenished.

- (2) Establish maintenance priorities based on the commander's guidance or intent and the factors of METT-T. Priorities may change as different phases of an operation are completed.
 - (3) Recover damaged vehicles only to the main supply route for further recovery by TF assets.
 - (4) Plan for increased consumption of petroleum, oil, and lubricants (POL).
 - (5) Push planned and preconfigured logistic packages of essential CSS items.
 - (6) Plan for increased vehicular maintenance, especially over rough terrain.
 - (7) Make maximum use of company maintenance teams and maintenance support teams in forward areas.
 - (8) Request unit distribution at forward locations.
 - (9) Increase use of meals-ready-to-eat (MRE).
 - (10) Use captured enemy supplies and equipment, particularly support vehicles and POL. (Before use, test for contamination.)
 - (11) Suspend most field service functions except airdrop and graves registration.
 - (12) Prepare for increased casualties and additional evacuation and graves registration requirements.
 - (13) Select supply routes, logistics release points, and subsequent trains locations based on map reconnaissance.
 - (14) Plan and coordinate EPW operations; expect more EPWs.
 - (15) Plan replacement operations based on known and projected losses.
 - (16) Consider the increasing distances and longer travel times to ammunition supply points (ASPs) and ammunition transfer points (ATPs).
 - (17) Ensure that CSS preparations for the attack do not compromise tactical plans.
- c. These considerations apply to some degree to all offensive operations. The change from one type of operation to another, such as from a hasty attack to a pursuit, does not require a major shift in CSS plans and procedures. However, the priorities and requirements for support may change. The XO, assisted primarily

by the S4, organizes the task force's CSS assets to permit uninterrupted support. The main purpose of CSS in the offense is to maintain the momentum of the attack.

7-10. SUPPORT OF THE DEFENSE

- a. The immediate purpose of the defense is to cause an enemy attack to fail or, in contrast to offensive operations, to break the momentum of the attack.
- b. As in offensive operations, perhaps the most critical time in the defense is the preparation stage. General considerations to be made in preparing for defensive operations include the following.
 - (1) Pre-position limited amounts of ammunition, POL, and barrier material in centrally located battle position in the forward area. Make plans to destroy those stocks if necessary.
 - (2) Resupply during limited visibility to reduce the chance of enemy interference.
 - (3) Plan to reorganize to reconstitute lost CSS capability. Identify personnel from the field trains as potential replacements to reestablish the lost capability.
 - (4) Use maintenance support teams in the UMCP to reduce the need to recover equipment to the brigade support area (BSA).
 - (5) Consider the additional transportation requirements for movement of Class IV barrier material, mines, and pre-positioned ammunition, plus the CSS requirements of additional engineer units assigned for preparation of the defense.
 - (6) In defensive operations, pre-position ammunition on occupied and prepared positions. However, plans must be made for the control of this ammunition.

7-11. CONTINUOUS SUPPORT

CSS elements conduct sustainment operations continuously; when maneuver companies are not fighting, task force CSS elements take advantage of the lull to prepare the maneuver elements for the next operation.

- a. Maintenance, repair work, and normal services are done whenever the opportunity exists. Repairing damaged equipment and

returning it to the fight requires early diagnosis and identification of faults and is done as far forward as possible.

- b. Emergency resupply is conducted when needed, but routine resupply is usually conducted at night. Vulnerability and limited cross-country mobility of CSS vehicles dictate that LOGPACs use existing roads at night.
- c. Continuous CSS operations require careful personnel management. Routine details, perimeter guard, and operator maintenance use support personnel time not spent on the road. A carefully planned and strictly enforced rest-work schedule or sleep plan is necessary to ensure continuous capability.

7-12. TASK FORCE LOGISTICS ESTIMATE

- a. A logistics estimate is an analysis of logistic factors affecting mission accomplishment. Logistics planners use these estimates to recommend courses of action and to develop plans to support selected concepts of operation. The key concerns of task force logistics planners are the status of supply Classes III, IV, and V; and the operational status of tanks, BFVs, and other combat vehicles.
- b. Logistics estimates at the battalion level are rarely written. They are frequently formulated in terms that answer the following questions.
 - What is the current and projected status of maintenance, supply, and transportation?
 - How much of what is needed to support the operation?
 - How will it get to where it is needed?
 - What external (FSB) support is needed?
 - Can the requirements be met using LOGPAC operations or are other techniques necessary?
 - What are the shortfalls and negative impacts?
 - What courses of action can be supported?

Section III. OPERATIONS

The organization of trains varies according to the mission and support assets assigned to the task force.

7-13. TASK FORCE TRAINS

- a. Trains may be centralized in one location (unit trains), or they may be echeloned in three or more locations (echeloned trains) as shown in Figure 7-1. Unit trains are formed in assembly areas and during extended tactical marches. Forming unit trains with a centralized rear CP provides ease of coordination and control, and increases trains' security. Unit trains are controlled by the S4 with the assistance of the S1.

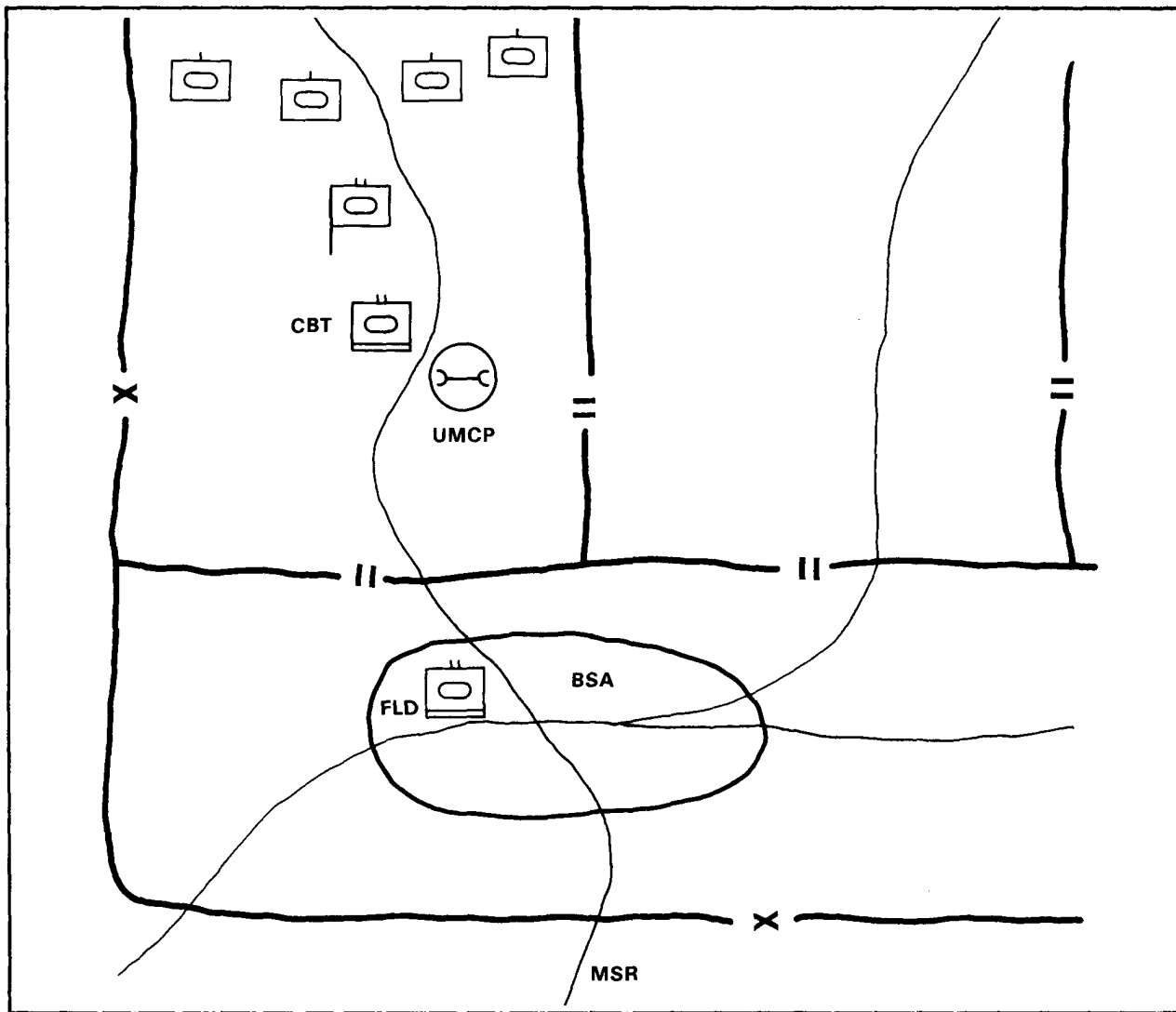

Figure 7-1. Echeloned trains.

- b. The task force CSS assets are normally echeloned into company combat trains, battalion combat trains, and battalion field trains. The battalion combat trains are organized to provide immediate critical support for the combat operation. Field trains are normally in the BSA and under the control of the HHC commander, who coordinates with the forward support battalion commander for security and positioning.
- c. The most forward CSS elements are the company combat trains. A medical evacuation team (routinely attached to the company) and the company maintenance team tracked vehicles, when forward, form the company trains. The company first sergeant positions these elements, tasks the medical evacuation team, and establishes priority of work for the company maintenance team.
- d. When operating in echeloned trains, the company supply sergeant usually operates from the field trains. Coordination between the company supply sergeant and the first sergeant is conducted through the combat trains CP to the HHC commander over the A/L net, and is supplemented by face-to-face coordination during LOGPAC operations.
- e. The battalion combat trains include the combat trains CP, medical platoon elements, decontamination assets, all uploaded Class III and V vehicles, elements of the communications platoon, and the nearby UMCP, with some supporting elements from the FSB. The combat trains are controlled by the S4, assisted by the S1. Elements of the combat trains operate on the A/L net and, when possible, are linked to the combat trains CP by landline.
- f. The battalion combat trains should be close enough to the FLOT to be responsive to the forward units, but not within range of enemy direct fire. The combat trains can expect to move frequently to remain in supporting distance of the combat elements. The following factors govern the positioning of the combat trains.
 - (1) Communications are required between the combat trains CP, the main CP, the field trains CP, brigade rear CP, and forward units.
 - (2) Room for dispersion and cover and concealment from both air and ground observation are desired.
 - (3) The ground must support vehicle traffic.
 - (4) A suitable helicopter landing site should be nearby.
 - (5) Routes to logistical release points or to company positions must be available.
 - (6) Movement into and out of the area must not be restricted.

- g. Built-up areas are good locations for trains. They provide cover and concealment for vehicles and shelter that enhances light discipline during maintenance. When built-up areas are used, battalion trains elements should occupy buildings near the edge of the area to preclude being trapped in the center.
- h. The UMCP is established and supervised by the BMO to provide forward maintenance support to the task force. It is normally located near the battalion combat trains. The UMCP and battalion combat trains may combine to form a base cluster for defense.
- i. The field trains are usually in the BSA and are controlled by the HHC commander. Generally, the field trains include the PAC, the mess sections, the company supply sections, the HHC command post, and the remainder of those elements of the maintenance and support platoons that are not forward.
- j. The BSA is that portion of the brigade rear area occupied by the brigade rear CP, the FSB, and the task force field trains. CSS assets in the BSA include elements from the FSB, maneuver and combat support unit field trains, and selected corps (COSCOM) and division (DISCOM) resources, as required.

7-14. LOGPAC OPERATIONS

- a. The most efficient resupply of forward task force units is accomplished by logistics packages (LOGPACs). LOGPACs are organized in the field trains by the company supply sergeant under the supervision of the HHC commander and the support platoon leader. LOGPACs are organized for each company team and separate element in the task force and moved forward at least daily for routine resupply. When possible, all LOGPACs are moved forward in a march unit, under the control of the support platoon leader. Special LOGPACs are organized and dispatched as required by the tactical situation and logistical demands.
- b. The task force S4 must plan and coordinate LOGPAC operations to ensure that they fully support the commander's tactical plans.
- c. Task force SOP establishes the standard LOGPAC. Normally, a company team LOGPAC includes the following:
 - (1) **Unit supply truck.** This vehicle contains the Class I requirements based on the ration cycle — normally, one hot meal and two MREs per man. The supply truck tows a water trailer and carries some full water cans for direct exchange.

In addition, the truck carries any Class II supplies requested by the unit, incoming mail, and other items required by the unit. The truck may also carry replacement personnel.

- (2) **POL trucks.** Bulk fuel and packaged POL products are on these vehicles.
 - (3) **Ammunition trucks.** These vehicles contain a mix of ammunition for the weapons systems of the company team. Unit SOP establishes a standard load; reports and projected demands may require changes to this standard load.
 - (4) **Vehicles carrying additional supplies and replacements.** These vehicles join the LOGPAC as coordinated by the support platoon leader and supply sergeant.
- d. LOGPACs for platoon-sized attachments are usually loaded on a single truck. Water and Class III resupply is often accomplished by using 5-gallon cans and pods mounted on trailers.
 - e. When the company LOGPAC has been formed, it is ready to move forward under the control of the supply sergeant. The support platoon leader normally organizes a convoy for movement of all company LOGPACs under his control; in emergencies, he dispatches unit LOGPACs individually. The convoy may contain additional vehicles, such as a maintenance vehicle with Class IX to move to the UMCP, or an additional ammunition or fuel vehicle for the combat trains. The LOGPACs move along the MSR to a logistics release point (LRP), where the unit first sergeant or a unit guide takes control of the company LOGPAC.
 - f. From the LRP, the company first sergeant or guide controls the LOGPAC and conducts resupply as described in FM 71-1. The unit first sergeant informs his supply sergeant of requirements for the next LOGPAC. The supply sergeant collects outgoing mail, personnel, and equipment for movement to the rear. The LOGPAC then follows unit SOP and returns to the LRP or to the field trains.
 - g. LRP locations are determined by the S4, based on the tactical situation. They should be well forward and easily located. Normally, two to four LRPs are planned. LRPs, as well as the MSR, combat trains, and field trains locations, are included on the operations overlay, if possible. The combat trains CP notifies subordinates and the field trains CP, well in advance, which LRP(s) will be used. The LOGPAC convoy arrival time at the LRP and the length of time it remains are normally established by SOP. If the tactical situation dictates otherwise, the S4 must determine the time and notify units accordingly. LOGPACs may be scheduled to arrive shortly after arrival at a BP or intermediate

objective. M1 units may also require more frequent Class III resupply. Subordinates must ensure that the resupply vehicles are returned to the LRP as soon as possible so that the vehicles can return to the field trains and begin preparation for the next mission. Class III and V vehicles never sit empty. If the LOGPAC cannot be completed on schedule, the combat trains CP must be notified.

- h. At least one senior representative from the combat trains (S4, S1, or senior NCO) should be present at the LRP while it is in effect. His purpose is to meet with the unit first sergeants and support platoon leader for coordination of logistical requirements, to ensure that the LOGPAC release and return takes place efficiently. A brief meeting is normally held immediately before the first sergeant picks up his LOGPAC. Coordination may include—
 - Changes in logistical requirements reflecting any last-minute task organization.
 - Reports on personnel, logistics, and maintenance from the first sergeants.
 - First-hand updates on the tactical situation and logistical status.
 - Delivery, receipt, and distribution of unit mail.
- i. The company supply sergeant or support platoon leader moves the LOGPAC from the LRP back to the field trains. The supply sergeant and support platoon leader then begin organization of the next LOGPAC.
- j. Resupply of the scout and mortar platoons, the main CP, combat trains, and attached support units must be planned and coordinated. The HHC first sergeant coordinates and supervises resupply of these elements. The HHC first sergeant operates near the task force main CP when forward and at the field trains CP upon completion of daily resupply.
 - (1) The platoon sergeant of these elements or senior NCO at a facility must report his requirements to the HHC first sergeant or to the combat trains CP. The most desirable method of resupply is to form small LOGPACs for these elements, which the platoon sergeant picks up at the LRP in the same manner as a company first sergeant. Attachments larger than a platoon must come to the task force with sufficient CSS vehicles to carry their LOGPACs.
 - (2) In some cases, the HHC first sergeant delivers the LOGPAC to the main CP, combat trains, and scout and mortar

- platoons. Attachments can receive resupply at one of these locations or as previously coordinated.
- (3) Another option is for attachments to be resupplied from a nearby company team LOGPAC. The S4 coordinates this resupply **before** the LOGPACs are dispatched.
 - (4) Resupply operations for the scout platoon pose several unique problems. Special procedures may be necessary to resupply the scout platoon, including:
 - Resupplying the platoon by having each track individually pull off line and move to a resupply site. (This method may be feasible when the platoon is performing security for a stationary force.)
 - Resupplying the platoon near the combat trains as the platoon repositions between missions.
 - Designating one Class III vehicle in the combat trains to fuel the platoon on short notice.
- k. Units in direct support or under OPCON of the task force are responsible for the coordination of resupply of their elements operating forward with the task force, except as noted.
- (1) The ADA battalion or battery commander coordinates for the task force to resupply ADA units in direct support with some classes of supply. This may be directed in higher headquarters SOPs and usually includes Class I, III, and V, and common item IX.
 - (2) The task force provides engineer materials (Classes IV and V) to supporting engineer units. Additionally, engineer units under OPCON of the task force receive Class I, III, V, and IX support to the maximum extent possible. This support is coordinated through or directed by brigade before the OPCON directive becomes effective.
 - (3) The parent unit S4 or company commander of the supporting element coordinates with the task force S4 or HHC commander on resupply of the forward elements. Normally, the supporting units' resupply elements assemble in the BSA and move to the task force field trains area. The HHC commander then dispatches these resupply elements forward, along with the task force LOGPACs, to the LRP. At the LRP, the platoon sergeant of the forward supporting element takes control of the resupply element. These resupply elements maintain contact with the combat trains CP while forward in the task force area. If coordinated between the supporting parent unit and the task force, the resupply of

these forward elements is directly managed by the task force. The parent unit must provide the additional logistical assets necessary to supplement the task force's capabilities. No matter how support was coordinated, any element within the task force area of operation must either be under the task force commander's control or at least remain in contact with the task force combat trains CP, to avoid interfering with task force maneuver.

- l. While the LOGPACs are the preferred methods of resupply, there will be times when other methods of resupply are required.
 - (1) **Resupply from the combat trains (emergency resupply).** The combat trains has a limited amount of Class III and V for emergency resupply. The S4 coordinates emergency resupply from the combat trains and then refills or replaces the combat trains' assets.
 - (2) **Pre-stocking.** Pre-stocking is the placing and concealing of supplies on the battlefield. This is normally done during defensive operations when supplies are placed in subsequent battle positions.
 - (3) **Mobile pre-positioning.** This is similar to pre-stocking except that the supplies remain on the truck, which is positioned forward on the battlefield.

7-15. CSS FOR CROSS-ATTACHMENTS

- a. **Types.** There are two types of cross-attachment that require different CSS considerations — between task forces and within a task force.
 - (1) **Cross-attachment between task forces.** When a company is cross-attached, the CSS necessary to support it is also cross-attached. This slice is established by higher headquarters SOP and usually consists of medical and maintenance support and supply assets for Classes I, III, V, and IX (see Figure 7-2). Mess support cross-attachment is coordinated on a case-by-case basis. The cross-attachment of CSS assets is between task forces — these assets do not belong to the cross-attached company. If the company is employed pure, these assets are used to support this company. However, if this company is further task organized, the support assets may need to be task organized as well to provide the most efficient support within the task force.

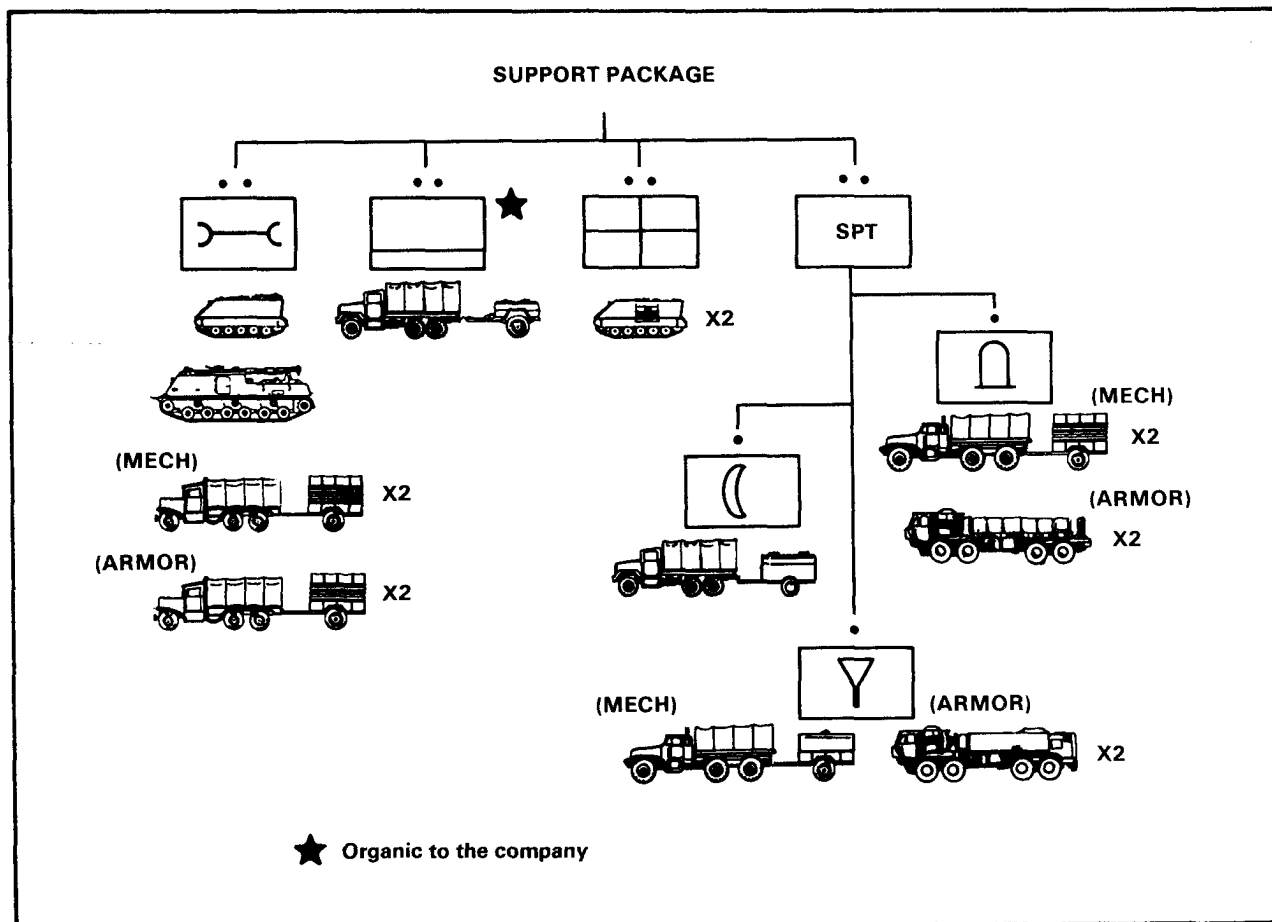

Figure 7-2. Detached company normal service support package.

- (a) **Mess support and Class I.** Companies are supported by a company mess team from the battalion mess section. The company mess team and its organic equipment may be detached to support the detached company. Under the combat field feeding system (CFFS), when a company is detached, only one cook and the equipment necessary to transport prepared meals are detached for mess support.
- (b) **Class III.** Fully loaded trucks from the support platoon, sufficient to refuel the company, are cross-attached. Usually, this means that for a mechanized infantry company, one tank and pump unit is needed; for a tank company, two heavy expanded mobility tactical trucks (HEMTTs) are needed.

- (c) **Class V.** Ammunition vehicles are cross-attached from the support platoon. These trucks should be loaded, prepared for the next LOGPAC operation. Usually, a mechanized infantry company requires two 5-ton trucks with trailers; a tank company requires two HEMTTs.
- (d) **Medical.** The medical aid/evacuation team that supports a company remains with the company when it is detached or cross-attached.
- (e) **Maintenance and Class IX.** One company maintenance team and a PLL clerk with a PLL truck and trailer are cross-attached to support the company. Selected high-demand repair parts are routinely carried on all company maintenance teams' tracked vehicles.
 - Consideration should be given to cross-attaching a team of mechanics (with transportation) from the battalion maintenance platoon services section to reinforce the repair capabilities of the company maintenance team.
 - The maintenance contact teams supporting the battalion to which the company will be attached must also be task organized to support the equipment mix.

(2) **Cross-attachment within a task force.**

- (a) When company teams are formed, the CSS requirements for each of the teams change from those of the base company organization. For example, a tank-heavy team (two tank platoons, one mechanized infantry platoon) has more personnel than the tank company and has different vehicles. These changes require support changes in the following areas:
 - **Class I and mess:** Support the additional personnel.
 - **Class III:** BFVs use less fuel than tanks — the operation determines how much less.
 - **Class V:** The tank company ammunition types (less one-third of the total), plus 25-mm, TOW, Dragon, and 5.56-mm to support the mechanized infantry platoon.
 - **Class IX and maintenance:** BFV PLL and BFV-trained mechanics are needed.
- (b) Task force CSS planners task-organize support assets to ensure that adequate bulk fueling capability and materiel-handling equipment are supporting the company teams. The S4's logistics estimate is the key in

this decision-making process. Additionally, the BMO may direct cross-attachments between company maintenance teams to facilitate forward repairs of all types of vehicles in the company teams, but this is less likely. Normally, the BMO directs that the attached company maintenance team continue to support the attached company (now a company team), and that repairs of the cross-attached platoon(s) vehicles be done in the UMCP by the wheeled assets of either the attached company maintenance team or the attached element from the maintenance services section.

- b. **Coordination and Control.** The coordination requirements for cross-attachment of CSS assets are established in higher headquarters' SOP. Usually, the coordination is between task force XOs using the brigade A/L net. This coordination should establish the numbers and types of supporting assets to be cross-attached, the time the attachment will occur, and the location(s) to which the attachments will move. Additional coordination, such as signals, signs and countersigns, and the requirements for guides, is also conducted as necessary.
- c. **Movement.** Movement from one task force area to the other may be done in one of two principal methods.
 - (1) **Movement under control of the cross-attached company commander.** If the cross-attached company is required to displace from its present location, the supporting CSS assets may be assembled to move with this unit.
 - (a) **Advantages.** It provides protection for the displacing CSS assets; it allows immediate refueling to the unit after its move; and it simplifies link-up with the receiving unit.
 - (b) **Disadvantages.** Time must be allowed for the company and the CSS assets to link up; and those elements positioned in the field trains may move a long distance, only to end up at another nearby field trains location.
 - (2) **Movement by element.** This method is frequently employed when the cross-attached company does not have to displace. In this case the company maintenance team wheeled vehicles, along with the PLL truck and any additional maintenance services section support, displace from one UMCP to another. The cross-attached support platoon elements displace from one field trains area to the other. These moves are made under the control of the senior NCO, who reports to the BMO or HHC commander at the gaining unit location.

- (a) **Advantages.** Assembly of the company and its supporting elements is not required; and the distance the field trains elements move is probably short.
- (b) **Disadvantages.** No protection is provided to the moving elements; and the attachment of CSS elements may occur piecemeal.

7-16. TRAINS SECURITY

- a. CSS elements behind the FLOT form base clusters and must be prepared to defend themselves against guerrillas and partisans, and forces that have broken through or bypassed the defense.
- b. The S4 is responsible for trains security when operating in a unit trains configuration. When trains are echeloned, the S4 is responsible for securing the combat trains, and the HHC commander is responsible for securing the field trains. If the task force commander collocates his field trains with the BSA, the HHC commander coordinates with the FSB commander and brigade rear CP to integrate the task force field trains into the BSA defensive plan. In all trains areas, a perimeter defense is normally planned. Elements in the trains are assigned a specific sector to defend. Mutually supporting positions that dominate likely avenues of approach are selected for vehicles armed with heavy machine guns. Reaction forces and OPs are established, based on the unit SOP. To enhance security, an alarm or warning system is arranged. Sector sketches, fire plans, and obstacle plans should be prepared. Rehearsals are conducted to ensure that all personnel know the part they play in the defensive scheme. The OIC at each location establishes a shift schedule for operations and security on a 24-hour basis.

7-17. COMMAND AND CONTROL

- a. CSS command and control is the responsibility of the task force XO. The S4 routinely coordinates all logistics operations, based on the XO's guidance. Command and control facilities are the combat trains CP and the field trains CP.
- b. The combat trains CP includes the S4 CP carrier (M577) with enough S1 and S4 personnel cross-trained to ensure continuous operation, and the communications platoon M577 and personnel. The combat trains must stay abreast of the tactical situation and task organization; monitor the TF command net to identify

CSS requirements; and receive requests, reports, and requirements from TF subordinate elements. Subordinate requirements are analyzed, consolidated, and forwarded to the field trains CP or to the appropriate supporting agency. The HHC commander coordinates and directs elements in the field trains to take action to meet the forward units' requirements.

- c. The field trains CP, established by the HHC commander, is the coordination and control center for the support platoon, PAC, maintenance platoon (-), and the battalion and company supply sections. Personnel from these sections operate the field trains CP under supervision of the HHC commander. The HHC commander coordinates all requirements for task force organic and attached elements with all units in the BSA and parent units as necessary.

7-18. COMMUNICATIONS

- a. At task force level, CSS communications may be by any combination of FM radio, RISE, courier, or wire. The A/L radio net is used for most CSS traffic. For lengthy reports, use messenger, wire, or radio teletypewriter (RATT).
- b. The combat trains CP is the NCS for the A/L net. The S4, S1, HHC commander, BMO, support platoon leader, medical platoon leader, company first sergeants, and others (as required) operate in the task force A/L net. The combat trains CP also operates in the brigade A/L net and in the task force command net (see Chapter 2).
- c. Communications are critical to expedite the CSS effort. Unit first sergeants must report their losses and requirements as soon as practical. When use of radio is not possible, messages are sent with resupply or evacuation vehicles. The combat trains CP and field trains CP maintain control of vehicles moving forward to the LRPs. Task force SOP establishes procedures for resupply without request in the event communications fail.

Section IV. SUPPLY

The supply system provides many types of supplies to the task force. The most important of these are ammunition, POL, and repair parts for weapons systems. To ensure continuous support, supplies are provided as far forward as the tactical situation will permit.

7-19. SUPPLY OPERATIONS

- a. The task force always maintains some combat-essential supplies and repair parts. These are called **combat loads, basic loads, and prescribed load lists**. The minimum stockage level is normally directed by division or higher. The purpose of these loads is to enable a unit to sustain itself in combat for a limited period, should there be an interruption in the resupply system. This period normally is 15 days for general supplies and repair parts and 3 to 4 days for Classes I, III, and V.
- b. The task force uses two methods to replenish its stocks.
 - (1) **Supply point distribution.** The task force, using organic transportation, goes to the supply point to pick up supplies. This is the normal method used by the task force support platoon to pickup supplies.
 - (2) **Unit distribution.** Supplies are delivered to a unit by transportation assets other than its own. The task force uses unit distribution to resupply its subordinate elements. When feasible, supplies are shipped directly from the issuing agency as far forward as possible, provided that the receiving unit has the materiel-handling equipment necessary to handle the shipping containers. This means that some supplies may be issued directly to the task force from COSCOM or even theater Army level, especially Class III and VII. This issue usually occurs no farther forward than the field trains.
- c. The task force uses the established requisition channels, regardless of the issue method chosen by higher headquarters.
- d. The S4 section is organized to process supply requests and to receive, issue, and temporarily store supplies. Distribution priorities for items in short supply are determined by the commander, based on recommendations by the S4 and the operational requirements of the task force.

7-20. CLASSES OF SUPPLY

Supplies are grouped into ten classes (Class I through X) and miscellaneous supplies.

- a. **Class I.** Subsistence items.
 - (1) Class I is automatically requested at brigade based on the daily strength report. The combat trains CP forwards the strength report to the field trains CP, which instructs the

mess section to prepare the rations. The support platoon gets subsistence from the FSB supply company's Class I point in the BSA. Rations are usually prepared in the field trains and delivered to the companies and attached units as part of the LOGPAC. MREs stored on combat vehicles are eaten only when daily Class I resupply cannot be accomplished.

- (2) Water is not a Class I supply item, but it is normally delivered with Class I. The HHC commander or support platoon leader coordinates with the FSB to pick up water from the MSB water supply point. Water is delivered to the units using water trailers. Also, forward water points can be tested and approved by the battalion surgeon. Each vehicle in the task force should carry water cans to be refilled or exchanged during Class I resupply and LOGPAC operations.
- b. **Class II.** Clothing, individual equipment, tentage, organizational tool sets and kits, handtools, and administrative and housekeeping supplies and equipment (including MOPP suits and decontamination items). The S4 section coordinates for supply sergeants to pick up Class II items from the FSB supply company in the BSA before normal LOGPAC operations. Expendable items, such as soap, toilet tissue, insecticide, clothing, and TA-50, are provided during the LOGPAC operations.
- c. **Class III.** POL (fuel, lubricants, and hydraulic oil).
- (1) Brigade S4's POL forecasts form the basis for division and corps stockage levels. POL is normally obtained by the battalion transportation section from the supply company's Class III supply point in the brigade support area. A formal request is not needed to obtain bulk fuel at a supply point. DISCOM fuel vehicles may be directed to deliver fuel to the combat trains area.
 - (2) Requests from companies are not required for POL and package products resupply. POL tankers move forward with each LOGPAC, with POL packaged products carried on each tanker. Requests are submitted to the combat trains CP for unusual requirements.
- d. **Class IV.** Construction materials including all fortification and barrier materials. Intensively managed construction and fortification materials are requested through the FSB and normally delivered by DISCOM or COSCOM transportation. Materials are carried as far forward as possible to reduce handling and should be prepackaged or preconfigured to suit the mission. Combat vehicles carry small amounts of these materials into battle. These combat loads can consist of wire, pickets, and lumber, as designated by unit SOP.

- e. **Class V.** Ammunition of all types. Class V supply is based on a required supply rate (RSR) and a controlled supply rate (CSR). The CSR is based on availability, and may therefore be lower than the RSR.
 - (1) The task force receives ammunition from the ammunition transfer point (ATP) in the BSA, which is operated by the FSB supply company. A backup ATP in the division support area is operated by the MSB supply and service company. The corps ASP is normally positioned near the division rear boundary. Both COSCOM and DISCOM trucks and helicopters can deliver ammunition directly to the battalion combat trains, if required.
 - (2) When ammunition resupply is required, the support platoon prepares a request for an amount based on unit expenditures (or projected requirements, in the case of prestocks) and the CSR. The request is validated by the division ammunition officer in the BSA. The ammunition is then picked up and transported to the field trains, where it remains loaded until needed for company resupply.
- f. **Class VI.** Personal demand and morale items, such as candy, cigarettes, soap, and cameras (nonmilitary sales items), and sundry packs. Requests for Class VI support are submitted by the S1 through supply channels when an Army exchange is not available. Resupply flow is the same as for Class I resupply.
- g. **Class VII.** Major end items, such as launchers, tanks, and other vehicles. Major end items are issued in combat based on battle loss reports. Large items may be delivered by COSCOM directly to the task force trains. The HHC commander sends ready-to-fight weapons systems forward with the LOGPAC. Smaller items are picked up by the support platoon at the distribution point in the brigade support area.
- h. **Class VIII.** Medical materiel, including repair parts peculiar to medical equipment. Medical supplies are obtained from the medical company in the brigade support area. Normally, these supplies are distributed by medical company ambulances returning from the BSA to the aid station and from the aid station to the company team by returning task force ambulances. Packaged and inventoried combat aid kits are replaced for used ones at the aid station. The medical platoon leader coordinates with the S4 for additional supplies as required or based on the S1 loss estimate and projection for mass casualties situations.
- i. **Class IX.** Repair parts and components, including kits, assemblies, and subassemblies — repairable or unrepairable — that are required for maintenance support of all equipment.

- (1) The task force stocks repair parts based on a combat PLL. The maintenance platoon administration section manages repair parts.
 - (2) Repair parts are issued in response to a specific request or by repairable (direct) exchange. The task force obtains repair parts from the Class IX supply point in the BSA. Parts are moved forward during routine LOGPAC operations or as required to the UMCP. The maintenance platoon requests Class IX items (less repairable exchange), and major Class IX subassemblies, such as engines and transmissions, by submitting requests to the maintenance company of the FSB. Repairable exchange for selected items (including components and subassemblies) is handled as a simple exchange with the MST of the unserviceable item, with an attached request for issue or turn-in, for a serviceable item. In combat, exchange and cannibalization is the norm to obtain critical Class IX supplies.
- j. **Class X.** Material to support nonmilitary programs such as agriculture and economic development (not included in Classes I through IX). Class X items are requested and obtained by the S4 based on civil-military requirements. Specific instructions for request and issue of Class X supplies are provided by division or higher.

7-21. SUPPORT OF NIGHT OPERATIONS

- a. While all classes of supply are affected by night combat, Classes I and III present the most significant problems. Class I supply points and kitchens must operate around the clock. At night, vehicles tend to operate in lower gear or idle for longer periods than during day, thereby requiring more fuel and oil.
- b. Other items of supply for night operations vary in demand depending on weather, terrain, and type of operation under consideration. For most tactical operations at night, units must expect an increased demand for —
 - Engineer tape and stakes.
 - Tarpaulin shelters.
 - NVD batteries.
 - Flashlights and filters (green, blue, red, and infrared).
 - Luminous tape and paint.
 - Red lens goggles.

- Replacement bulbs.
- Replacement NVDs.
- Chemical light sticks.

Section V. MAINTENANCE

Maintenance involves inspecting, testing, servicing, repairing, requisitioning, and recovering. Repair and recovery are completed as far forward as possible, at the lowest capable echelon. When equipment cannot be repaired on site, it is moved only as far as necessary for repair. When all maintenance requirements of the task force cannot be met, the XO determines maintenance support priorities for subordinate units based on operational requirements of the task force and on recommendations of the S4 and BMO.

7-22. MAINTENANCE TERMS

The following are explanations of some common maintenance terms.

- Maintenance Support Team (MST).** A mobile team from the FSB maintenance company organized and equipped to provide forward support.
- Unit Maintenance Collection Point (UMCP).** A facility operated by the battalion maintenance platoon. It is the first point to which task force maintenance teams recover equipment, and at which some direct support maintenance is performed.
- Controlled Exchange.** The removal of serviceable repair parts and components from unserviceable but repairable vehicles (end items) to get a like vehicle (end item) operational.
- Cannibalization.** The removal of serviceable and unserviceable parts and components from damaged equipment. Cannibalization is aggressively used to keep the maximum number of combat systems in the battle.
- Battlefield Damage Assessment and Repair.** The act of inspecting battle damage to determine its extent, classifying the type of repairs required, and determining the maintenance activity best suited to accomplish the repair. Battlefield damage repair involves the immediate repair of equipment by field-expedient methods.
- Company Maintenance Team (CMT).** A team from the maintenance platoon that is organized and equipped by modified

table of organization and equipment (MTOE) to provide forward unit maintenance support. It operates with the company and from the UMCP. These teams are tailored by the BMO to provide support according to the mix of weapons systems within a company team. Normally, the team deploys a recovery vehicle and a maintenance track forward with the company while the remainder of the team remains in the UMCP.

7-23. CATEGORIES OF MAINTENANCE

The Army maintenance system consists of three levels of maintenance: unit, intermediate, and depot.

- a. **Unit.** Unit maintenance consists of preventive maintenance tasks performed by the operator and crew and those performed by unit mechanics. Unit mechanics isolate faults with test equipment, make visual inspection, make minor adjustments, and repair end items by exchanging faulty modules and components. These actions can be performed on site or in the UMCP. Unit mechanics also perform recovery tasks.
- b. **Intermediate.** Intermediate maintenance can be either direct support or general support.
 - (1) **Direct support.** DS mechanics diagnose and isolate equipment or module failure, adjust and align modules and components, and repair defective end items. Maintenance support teams (MSTs), from the FSB operate from the UMCP. If equipment cannot be repaired in the UMCP because of time constraints, workload, or the tactical situation, it is recovered to the FSB maintenance company in the BSA for repair.
 - (2) **General support.** GS maintenance involves repair of modules and components by replacing internal pieces or parts, and repair of end items involving time-consuming tasks. GS is provided by division and corps in support of the maintenance system.
- c. **Depot.** Depot maintenance personnel rebuild end items, modules, components, and assemblies; perform cyclic overhaul; perform inspections; and complete modifications requiring extensive disassembly or elaborate testing.

7-24. MAINTENANCE FORWARD

- a. Combat power is maximized when disabled equipment is repaired as far forward and as quickly as possible. The BMO, in

coordination with the XO, directs the maintenance effort for the task force by using established time guidelines and by coordinating maintenance actions.

- b. Battle damage assessment and diagnosis indicate repair time. An item is repaired on site or recovered directly to the appropriate maintenance echelon in the appropriate support area based on —
 - Tactical situation.
 - Echelon of work required.
 - Availability of required repair parts.
 - Current workload in each area.
 - Maintenance time guidelines.
- c. Maintenance time guidelines establish the maximum time that unserviceable equipment will remain in various support areas. Table 7-1 lists typical maintenance time guidelines. These times are flexible and should not be considered restrictive.

Time for Repair (Hours)	Location
Less than 2	On site
2 to 6 (and can be towed until repaired)	UMCP
6 to 24 (or less than 6, if vehicle cannot be towed)	Field trains/FSB maintenance company (BSA)
24 to 36	DSA

Table 7-1. Maintenance time guidelines.

7-25. MAINTENANCE CONCEPTS

The following discussion of battlefield maintenance concepts places the various maintenance echelons into proper perspective. The discussion illustrates how echelons overlap to provide continuous maintenance support to the maneuver units.

- a. The BMO task-organizes the maintenance platoon based on his analysis of current and anticipated requirements. He is concerned with providing the appropriate support at each of three locations: the maneuver company, the UMCP, and the field trains.

- b. Normally, the BMO positions CMT recovery vehicles and M113's with crews to support each company. This provides a quick fix capability for those items that can be repaired in less than 2 hours and recovery capability for those items requiring more extensive repairs. The remainder of the CMT operates from the UMCP under the control of the BMO. The entire company maintenance team may go forward when the situation permits, to provide maximum support forward.
- c. The UMCP is normally task organized with the maintenance platoon headquarters (-), one PLL truck from the administration section, the remaining VTRs from the recovery section, track automotive and turret repair teams from the service section, the wheeled-vehicle assets from the company maintenance teams, and the DS MST. The task organization of the UMCP is modified, based on the BMO's analysis of the maintenance requirements and the tactical situation. The UMCP cannot become a collection point for nonoperational vehicles to the extent that it cannot move with an hour's notice. Anything that cannot be repaired in the UMCP or that cannot be towed by UMCP assets is recovered to the field trains or directly to the FSB maintenance company in the BSA.
- d. The remainder of the maintenance platoon is in the field trains under the control of the battalion motor sergeant.
- e. The battalion maintenance platoon organizes to support cross-attachment as well as pure battalion operations.
 - (1) To support this concept, the administration section configures four PLL trucks and trailers to carry the PLL needed to support one maneuver company each. These vehicles also transport enough packaged POL to support repair operations. One of the remaining PLL trucks and trailers is configured to carry the PLL associated with HHC tracked vehicles, and, in mechanized infantry only, anti-armor company. The remaining PLL truck and trailer is configured to carry the PLL for the battalion's wheeled vehicles; it operates from the field trains.
 - (2) Additionally, some high-demand, low-volume parts are carried on the company maintenance team's tracked vehicles. The selection of parts that are carried forward on the tracked vehicles, as well as the breakout of parts to be carried on each PLL truck and trailer, should be addressed in the battalion maintenance platoon SOP.
 - (3) Direct support maintenance element priorities are set by the BMO. Since the maintenance elements are equipped and

trained to support the unit, task-organizing direct support maintenance assets is not routinely done. PLL parts, special tools, and test sets are not easily split.

- f. The CMT tracked vehicles are forward in the company trains. These vehicles carry the tool boxes, some unit-level technical manuals, and a limited number of special tools and repair parts. (M1-M2 test equipment normally remains at UMCP because of its size: it may be sent forward as needed, based on the BMO's and CMT's assessments.) The CMT usually repairs the damage on-site if the repair can be accomplished within 2 hours.
- g. If a damaged vehicle cannot be repaired within 2 hours, it is recovered to the UMCP or the field trains. However, before a recovery vehicle is committed, other recovery means are attempted. The CMT recovers the vehicle only as far as a collection point, or the main supply route (MSR).
- h. The damaged vehicles recovered to the UMCP are repaired by maintenance platoon elements or MSTs from the FSB maintenance company. When not involved in on-site repairs, the company maintenance teams may also repair vehicles in the UMCP. This is especially true of work requiring diagnostic test equipment that cannot be taken into the combat positions.
- i. Vehicles that cannot be repaired within 6 hours, or that would otherwise overload the capability of the UMCP, are recovered to the field trains or directly to the FSB maintenance company collection point for repair. This recovery may be accomplished by the company maintenance team vehicle, tracked, recovery (VTR); by the company maintenance team VTR to a collection point or MSR, then by a maintenance platoon VTR; or by a combination of VTR and heavy equipment transporters (HETs). The BMO coordinates and directs the method to be used. The use of HETs is the preferred, but they are restricted by road requirements and availability. HETs are requested through the FSB maintenance company. Some crew members accompany the vehicle to the rear to assist mechanics in the repair of the vehicle and return it to the unit when repaired. They also man operational weapons systems on the vehicle to provide additional security to rear areas. Communications-electronic equipment installed in the vehicle is evacuated with the vehicle. Crewmen not accompanying the vehicle remove personal equipment and any special equipment before the vehicle leaves the area.
- j. The UMCP usually displaces with the other elements of the combat trains. During periods of frequent displacement, the BMO may direct that the UMCP displace by echelon. In this case, some assets of the maintenance platoon, including the BMO, complete repair on vehicles at the old UMCP before displacing forward

to the new location. Maintenance platoon assets not involved in repairs move with the remainder of the combat trains and establish the forward UMCP.

- k. During rapid forward moves, such as in the exploitation, the UMCP conducts only essential repairs and simple recovery. Other disabled vehicles are taken to collection points on an MSR and remain to be repaired or evacuated. Field trains and the maintenance company of the FSB displace forward to subsequent locations. The BMO coordinates the repair or evacuation with the battalion motor sergeant in the field trains.
- l. In the field trains, remaining elements of the battalion maintenance platoon perform other tracked and wheeled vehicle maintenance and Class IX resupply. The battalion motor sergeant coordinates requirements with the HHC commander and with the maintenance company of the FSB. He also coordinates maintenance requirements with the parent headquarters of any attached or supporting elements working with the task force.

7-26. MAINTENANCE OPERATIONS AT NIGHT

- a. The following techniques may be used during night maintenance operations. At night, maintenance is accomplished in lightproof or light-suppressing maintenance tents or other shelters. Permanent structures, such as warehouses, civilian garages, and barns, are preferred.
- b. If large shelters are not available, mechanics replace small components under a lean-to or some other lightproof shelter constructed of a tarpaulin or a poncho. Chemical light sticks provide adequate light for most repairs.
- c. Most maintenance work is accomplished in the fighting positions or in the UMCP. To prevent congestion and confusion, a staging area is designated for vehicles awaiting repair. Tow cables or tow bars remain attached to vehicles that cannot move under their own power. This makes it easier to move the vehicle on short notice.

Section VI. FIELD SERVICES

This section describes field services provided to the task force.

7-27. GRAVES REGISTRATION

Graves registration services are provided by the MSB supply and service company. Grave registration at task force level consists of

three functions: collection, identification, and evacuation. Casualty feeder reports (DA Form 1156) and witness statements (DA Form 1155) are completed by the soldier who has knowledge of the casualty and sent to the field trains with the returning LOGPACs. Military equipment is collected and turned over to the supply sergeant during LOGPAC operations. Remains are placed in human remains pouch, along with personal effects, and evacuated with returning LOGPAC vehicles to the field trains. If necessary, companies evacuate remains to the MSR and report the location to the combat trains CP. A collection point may be established, if necessary, at the combat trains under the control of the S4. In any case, remains are evacuated as rapidly as possible to the brigade collection point in the BSA. (See FM 10-63-1.)

7-28. CLOTHING EXCHANGE AND BATH

Clothing exchange and bath (CEB) services are provided by the MSB supply and service company. Clothing exchange (or gratuitous issue) and bath service is requested from the MSB through the brigade S4. A request for CEB service must specify the location of the unit making the request, the desired time for service, and the range of clothing sizes for unit members. The requesting unit must be prepared to furnish soldiers to help setup the CEB operation. Normally, there is one CEB point per BSA.

7-29. SALVAGE

Salvage services are provided by FSB supply company. A salvage collection point is established in the BSA by the FSB supply company. It receives serviceable, unserviceable (repairable), discarded, abandoned, and captured supplies and equipment. The salvage point will not accept COMSEC or medical supplies, toxic agents, radioactive materials, contaminated equipment, aircraft, ammunition, and explosives.

7-30. LAUNDRY AND RENOVATION

Laundry and renovation services are provided by corps CSS (COSCOM) when the tactical situation permits. This service is coordinated through the brigade S4.

7-31. AIRDROP/AIRLIFT

Airdrop/airlift support is provided by corps and division aviation brigade assets. The S4 requests airdrop/airlift support through the

brigade S4 and ensures that a drop or landing zone is prepared and marked.

Section VII. PERSONNEL AND HEALTH SERVICES SUPPORT

Personnel and health service support functions sustain the morale and welfare of the soldier. At battalion level, these include personnel and administrative (P&A) services, chaplain activities, legal services, finance services, public affairs, postal services, EPW support, and health services support.

7-32. PERSONNEL AND ADMINISTRATIVE SERVICES

P&A services are the responsibility of the task force S1; they include the following.

- a. **Strength Accounting.** Company teams and attached units submit a personnel daily summary report to the S1 in the combat trains CP. The S1 forwards a task force consolidated report through brigade S1 to the division G1/AG main. The PAC in the field trains is given an information copy. These reports are the basis for individual replacements and Class I resupply. Accurate strength reports also provide the commander and staff with information to plan operations. Daily reports are included in the task force SOP.
- b. **Casualty Reporting.** The S1 ensures that both strength and casualty reporting occur in a timely and accurate manner. Initial reports are usually verbal. Written reporting occurs as soon as possible after the event. It is initiated by the squad leader, tank commander, or any individual having knowledge of the incident. The casualty feeder report (DA Form 1156) is carried by all small-unit leaders to report battle casualties and nonbattle casualties. It provides initial information for notifying next of kin and for payment of benefits. When a soldier is reported missing or missing in action or when the remains are not under US control, a witness statement (DA Form 1155) accompanies the casualty feeder report. The first sergeant collects and forwards reports to the combat trains CP. The S1 cross-checks the reports, requests any needed clarification, adjusts unit strength reports, and forwards the reports through the PAC to the brigade S4.
- c. **Replacement Operations.** Replacement flow is monitored by the PAC in the field trains. The HHC commander establishes a replacement receiving point (RRP) in the field trains and notifies the brigade S1 of its location. All replacements or hospital

returnees are brought to the RRP for initial processing. The division AG is normally responsible for delivering replacements to the RRP. Replacements are briefed on SOPs and equipped with weapons and field gear before departing the field trains. They move forward to their unit with the LOGPAC.

- d. **Other Administrative Services.** During lulls in the battle, the S1 and PAC complete all other P&A actions necessary. If possible, these are accomplished by forming personnel contact teams that move forward to company locations. Special consideration is given to timely processing of awards and decorations.

7-33. CHAPLAIN ACTIVITIES

Chaplain activities are provided by the unit ministry team (one chaplain and one chaplain assistant) operating from the combat trains. The unit ministry team is dedicated to serving the spiritual needs of soldiers. Chaplain activities include essential subfunctions of providing worship opportunities; administration of sacraments, rites, and ordinances; pastoral care and counseling; advising the commander and staff on matters of religion, morals, and morale; ministry in support of battle fatigue; and religious support enhancing soldier morale and unit cohesion. Chaplains also routinely visit unit soldiers in nearby hospitals.

7-34. LEGAL SERVICES

Legal service support is coordinated by the S1 section. It is provided to the task force on a GS basis by the staff judge advocate of the division. It includes —

- Legal advice to commanders on all matters involving military law, domestic law, foreign law, international law, and administrative proceedings.
- Representation to accused and suspects in military justice matters and to personnel pending adverse military personnel action.
- Advice to soldiers on complaints, reports of survey, and the right to silence in administrative proceedings.
- Legal assistance to soldiers on personal civil legal matters.

7-35. FINANCE SERVICES

Finance support to the task force is usually provided by mobile pay teams (MPT) from the corps' area finance support unit. During low-intensity operations, the MPTs make combat payments to soldiers

in amounts established by the theater army commander, or in lesser amounts if the soldier so desires. The brigade commander may establish an amount less than the maximum for personnel of the brigade, based on the tactical situation and needs of the soldier. When and where the soldier is paid is determined by the commander, and coordinated by the S1.

7-36. PUBLIC AFFAIRS

Information (public affairs) support for soldiers and commanders in wartime is provided by the division public affairs office. Public affairs officers (PAOs) provide public affairs advice and service concerning all matters of soldier and media interest.

7-37. POSTAL SERVICES

A postal element, assigned to the Corps DS postal company, receives and separates mail by battalion, then turns it over to the brigade S1. The battalion mail clerk receives and sorts the mail by task organization and distributes it to the unit supply sergeant (assistant mail clerk), who delivers it to the first sergeant or to the soldier himself (accountable mail) during LOGPAC resupply.

7-38. PRISONERS OF WAR

The S1 plans and coordinates EPW operations, collection points, and evacuation procedures. Prisoners of war are evacuated from the task force area as rapidly as possible. The capturing company is responsible for guarding prisoners until relieved by proper authority, recovering weapons and equipment, removing documents with intelligence value, and reporting to the main and combat trains CPs. Prisoners may be evacuated to the vicinity of the combat trains or UMCP for processing and initial interrogation. Crews of vehicles undergoing repair or unoccupied mechanics are used as guards. Prisoners are then moved to the brigade EPW collection point on returning LOGPAC vehicles or by transportation coordinated by the S4. As necessary, the S2 reviews and reports any documents or information of immediate value. The S4 coordinates evacuation of large amounts of enemy equipment. Wounded prisoners are treated through normal medical channels but kept separated from US and allied patients.

7-39. HEALTH SERVICES SUPPORT

- a. **Planning.** Task force health services support is planned by the medical platoon leader or battalion surgeon and S1. It is provided

by the battalion medical platoon. Backup support is provided by the FSB medical company. To support task force operations, the medical platoon leader or battalion surgeon and medical operations officer must understand the scheme of maneuver as well as the support plan of the FSB medical company.

- b. **Organization.** The medical platoon is organized with a platoon headquarters, a treatment squad, an ambulance section, and a combat medic section. This organization facilitates quick evacuation of wounded soldiers so that they may be treated by trained medical personnel within 30 minutes of the time they are wounded.
- (1) The platoon headquarters and the medical treatment squad can form one or two battalion aid stations (BASS) capable of operating from or forward of the combat trains.
 - (2) The ambulance section operates from company trains and from the BAS. Tracked ambulances and crews habitually work with the same company, as do medics from the combat medic section. The senior combat medic is in charge of this company aid/evacuation team.

c. **Functions.**

(1) **Maneuver company aid/evacuation team.**

- Provides emergency medical treatment and protection for the sick and wounded.
- Assists combat vehicle crews in evacuating injured crewmen from their vehicles.
- Provides medical evacuation.
- Initiates a field medical card for the sick and wounded, and, time permitting, completes this card on deceased personnel.
- Screens, evaluates, and treats patients suffering from minor illnesses and injuries; returns patients requiring no further attention to duty; notifies first sergeant of those requiring evacuation to the BAS.
- Remains abreast of the tactical situation, and complies with the instructions of the unit first sergeant.
- Ensures that the company commander and the battalion surgeon are informed of the status of patients seen and the overall status of health and welfare of the company.
- Trains unit personnel to enable them to perform self aid and buddy aid.

- Provides trained combat lifesavers with medical supplies as required.
- (2) **Battalion aid station.** This facility has medically trained personnel to stabilize patients for further evacuation, to perform immediate lifesaving or limb-saving techniques, and to treat patients for minor wounds or illnesses and return them to duty. The BAS can operate two treatment teams for a limited time if the tactical situation requires it. Other functions of the BAS include—
- Receiving and recording patients.
 - Notifying the S1 of all patients processed and disposition of casualties as directed by SOP.
 - Preparing field medical records and verifying information on field medical cards.
 - Requesting MEDEVAC.
 - Monitoring personnel, when necessary, for radiological contamination before medical treatment.
 - Treating small numbers of chemical casualties.
 - Monitoring the activities of aid or evacuation teams.

d. **Medical Evacuation.** Evacuation is the responsibility of the next higher level of medical support; for example, the FSB medical company evacuates patients from the BAS, or coordinates from corps resources. Patients are evacuated no farther to the rear than their condition requires, and they are returned to duty as soon as possible.

- (1) Evacuation within the task force is routinely conducted by the medical platoon ambulance section. Outside the task force, evacuation may be conducted by ground or air.
- (2) Aerial means are used to evacuate patients as often as possible. Ground ambulances are used only for those patients who cannot be evacuated by air. Which means should be used is determined by the patient's condition, the availability of aircraft, and the tactical situation. Normally, the physician or PA treating the patient makes this determination.
- (3) The platoon leader may coordinate with the S4 for additional transportation; he ensures that temporary ambulances have medically trained personnel and medical supplies necessary for casualty movement. Returning supply vehicles can be used for transportation. In the event of mass casualties, any type of vehicle may be used. The battalion SOP should address how to get casualties to ambulance exchange points for transportation to the next level of medical treatment.
- (4) The unit that controls the sector has the implied task of providing medical assistance or evacuation to specialized platoons or personnel within the sector.

- e. **Medical Supply and Property Exchange.** The medical platoon maintains a two-day stockage of medical supplies IAW guidance from the brigade or division surgeon. To prevent unnecessary depletion of blankets, litters, splints, and so forth, the receiving medical facility exchanges like property with the transferring agency. Medical property accompanying patients from allied nations is disposed of in accordance with STANAG 2128, Appendix C.
- f. **Preventive Measures.** Experience in World War II, Korea, and Vietnam indicates that the majority of hospital admissions were for disease and nonbattle injury. Commanders can reduce disease and nonbattle injury by emphasizing preventive medicine, safety, and personal hygiene (see FM 21-10).
- * g. **Combat Lifesaver.** The combat lifesaver is a nonmedical soldier selected by the commander for medical training beyond basic first-aid procedures. Soldiers chosen and trained as combat lifesavers serve in this capacity when the situation permits, but mission accomplishment always takes priority.
 - (1) Combat lifesaver duties include stabilizing the casualty before he can be medically evacuated. Combat lifesavers also help evacuate casualties.
 - (2) When soldiers know they have combat lifesavers, it increases morale, because soldiers know they will be cared for if wounded.
 - (3) Units should strive to have one combat lifesaver for each team-sized organization. This includes armored vehicle crews, maintenance platoons, and all CPs as well as maneuver platoons and companies.

Section VIII. RECONSTITUTION

Planners must be prepared for mass casualties, mass destruction of equipment, and the destruction or loss of effectiveness of entire units. This section discusses reconstitution and shows how battalions or companies that have been catastrophically depleted or rendered ineffective are returned to combat effectiveness. Reconstitution consists of the actions to restore companies to a desired level of combat effectiveness commensurate with mission requirements and availability of resources. Reconstitution differs from sustaining operations in that it is undertaken only when a unit is at an unacceptable level of combat readiness, whereas sustainment operations are routine actions to maintain combat readiness. Commanders reconstitute by either reorganization or regeneration.

7-40. REORGANIZATION

Reorganization is the action taken to shift resources within a degraded company to increase its combat power. Measures taken include cross-leveling equipment and personnel, matching operational weapons systems with crews, or forming composite companies.

- a. Immediate battlefield reorganization is the quick and often temporary restoration of companies conducted during an operation; for example, reorganizing on the objective and implementing the established succession of command.

- b. Deliberate reorganization is a permanent restructuring of the unit. It is the type of reorganization considered during reconstitution planning. Deliberate reorganization is supported with higher echelon resources (such as maintenance and transportation), and additional replacements and other resources may be made available. Deliberate reorganization must be approved by the parent-unit commander one echelon higher than that reorganized. For example, the task force commander cannot approve the deliberate reorganization of an attached company, but the parent battalion commander or the brigade commander can approve it.

7-41. REGENERATION

Regeneration is incremental or whole-unit rebuilding through large-scale replacement of personnel, equipment, and supplies; reestablishing or replacing essential command, control, and communications; and conducting the necessary training for the rebuilt unit. The unit must be removed from combat to be regenerated. Divisions regenerate battalions or companies; corps regenerate brigades or battalions. To regenerate a unit, the division or corps commander must balance priorities for supplies, equipment, or other CSS, and he must task the support organizations to provide direct support to the regenerated unit.

* APPENDIX A

MECHANIZED INFANTRY AND ARMORED, LIGHT INFANTRY, AND SPECIAL OPERATIONS FORCES OPERATIONS

Employing mechanized infantry and armored battalions with light and special operations units can be a combat multiplier. These operations take advantage of the light unit's ability to operate in restrictive terrain such as urban areas, forests, and mountains. This increases the survivability of the overall force. At the same time, it has the advantage of the mobility and firepower inherent in mechanized infantry and armored units. Forces should be mutually supporting, based on the commander's concept of employment. This ensures mechanized and light assets are integrated and synchronized. Working with special operations forces (SOF) gives the commander access to time-sensitive intelligence. Also, SOF teams can help the brigade conduct combat missions. This appendix discusses what the mechanized infantry and armored battalion commander must consider in planning for and executing three types of tactical operations: those in which the battalion is provided with a light company, those in which the battalion is part of a light brigade, and those in which the battalion works with special operations forces.

CONTENTS	
PARAGRAPH	PAGE
Section I. ORGANIZATION	A-2
A-1 Capabilities and Limitations	A-2
A-2 Organization of Light Force Brigades	A-3
A-3 Organization of Light Force Battalions	A-6
A-4 Organization of Light Force Companies	A-8
A-5 Organization of Special Operations Forces	A-12
A-6 Safety Considerations	A-13
Section II. EMPLOYMENT CONCEPTS	A-13
A-7 Planning Considerations	A-14
A-8 Offensive Operations	A-16
A-9 Offensive Missions and Roles	A-19
A-10 Exploitation	A-20
A-11 Defensive Operations	A-21
A-12 Defensive Missions and Roles	A-22
A-13 Retrograde Operations	A-23
A-14 Retrograde Missions and Roles	A-24
Section III. INTEGRATION AND SYNCHRONIZATION OF SPECIAL OPERATIONS FORCES	A-25
A-15 Special Operations Command and Control Element	A-25

PARAGRAPH	PAGE
A-16 Employment of Special Operations Forces	A-26
A-17 Mechanized Infantry Battalion Tasks	A-26
Section IV. MILITARY OPERATIONS ON URBANIZED TERRAIN.	
A-18 Restrictions on Armored Vehicles	A-27
A-19 Role of Infantry	A-27
A-20 Light and Mechanized Infantry and Armored Operations	A-27
A-21 Offensive Considerations	A-28
A-22 Defensive Considerations	A-29

Section I. ORGANIZATION

Employing light infantry, mechanized infantry and armored, and SOF forces together does more than capitalize on the unique characteristics of each; it also helps offset their limitations. This means commanders must know each force's capabilities and limitations. The commanders must also apply the principles of war to combined light infantry, mechanized infantry and armored, and SOF forces operations, and must synchronize all combat, CS, and CSS units.

A-1. CAPABILITIES AND LIMITATIONS

The employment of a mixed force must be based on sound METT-T analysis. Commanders must effectively integrate light infantry, mechanized infantry and armored, and SOF forces by using them to complement one another.

a. **Light Force Capabilities.** Light forces are designed to do the following:

- (1) Seize, occupy, and hold terrain.
- (2) Move by aircraft, truck, or amphibious vehicle or, in areas identified as SLOW or NO-GO for mounted forces, move by foot.
- (3) Conduct operations along with mechanized infantry and armored forces.
- (4) Conduct air assault operations.
- (5) Take part in counterinsurgency operations within a larger unit.
- (6) Rapidly accept and integrate augmenting forces.

b. **Light Force Limitations.** Light forces are limited by the following factors:

- (1) They must depend on nonorganic transportation for rapid movement over long distances.

- (2) They are vulnerable to NBC unless they are dug-in or otherwise protected. Without protective clothing, light infantry soldiers are also vulnerable to prolonged NBC exposure.
 - (3) They require external (divisional) support when they must operate for an extended period.
- c. **Special Operations Forces Capabilities.** Special operations forces can do the following:
- (1) Infiltrate and exfiltrate specified operational areas by air, land, or sea.
 - (2) Conduct operations in remote areas and nonpermissive environments for an extended time, with little external direction and support.
 - (3) Develop, organize, equip, train, advise, and direct indigenous military and paramilitary personnel.
 - (4) Train, advise, and aid US and allied forces.
 - (5) Conduct reconnaissance, surveillance, and target acquisition.
 - (6) Conduct direct-action operations. These include raids, ambushes, use of snipers, and emplacement of mines and other munitions.
 - (7) Provide terminal guidance for precision-guided munitions.
 - (8) Conduct rescue and recovery operations.
- d. **Special Operations Forces Limitations.** Special operations forces are limited by the following factors:
- (1) They must depend on the resources of the theater army to support and sustain operations.
 - (2) They cannot conduct conventional combined arms operations. They can only advise or direct indigenous military forces who are conducting this type of operation.
 - (3) They lack an organic combined arms capability.
 - (4) They can provide security for operational bases only at the cost of severely degraded operational and support capabilities.

A-2. ORGANIZATION OF LIGHT FORCE BRIGADES

An infantry brigade is a combination of infantry battalions and other supporting units commanded by a brigade headquarters. The infantry brigade participates in division or corps operations IAW prescribed principles and concepts (FM 100-15 and FM 71-100-2). The only unit permanently assigned to a brigade is its HHC. The HHC provides command and control over units attached to or supporting the brigade. Minor personnel and equipment differences exist between HHCs. Figures A-1 through A-4 show examples of how brigades may be task-organized.

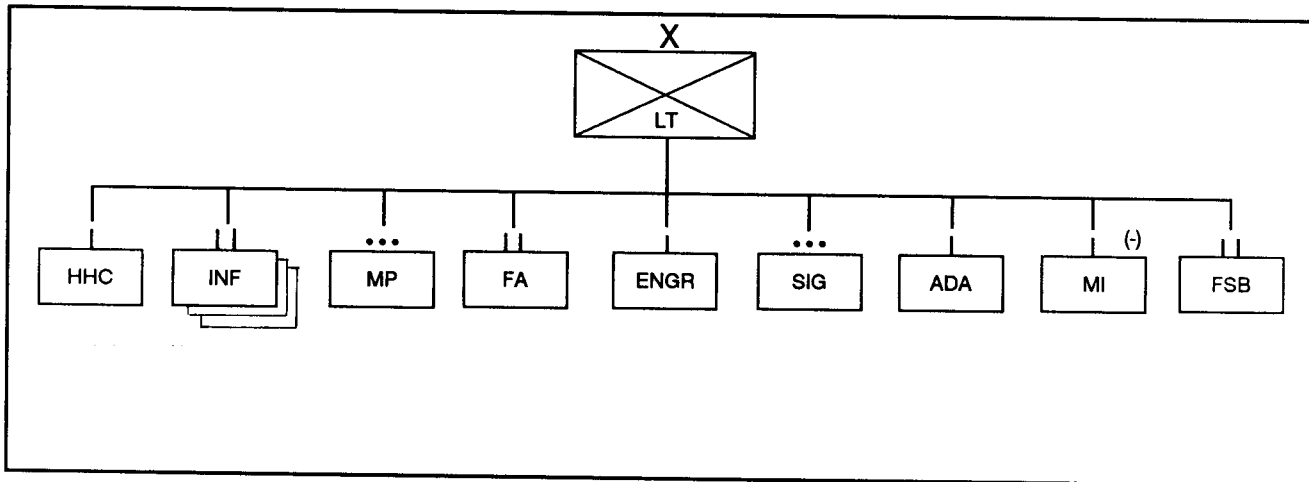

Figure A-1. Example light infantry brigade task organization.

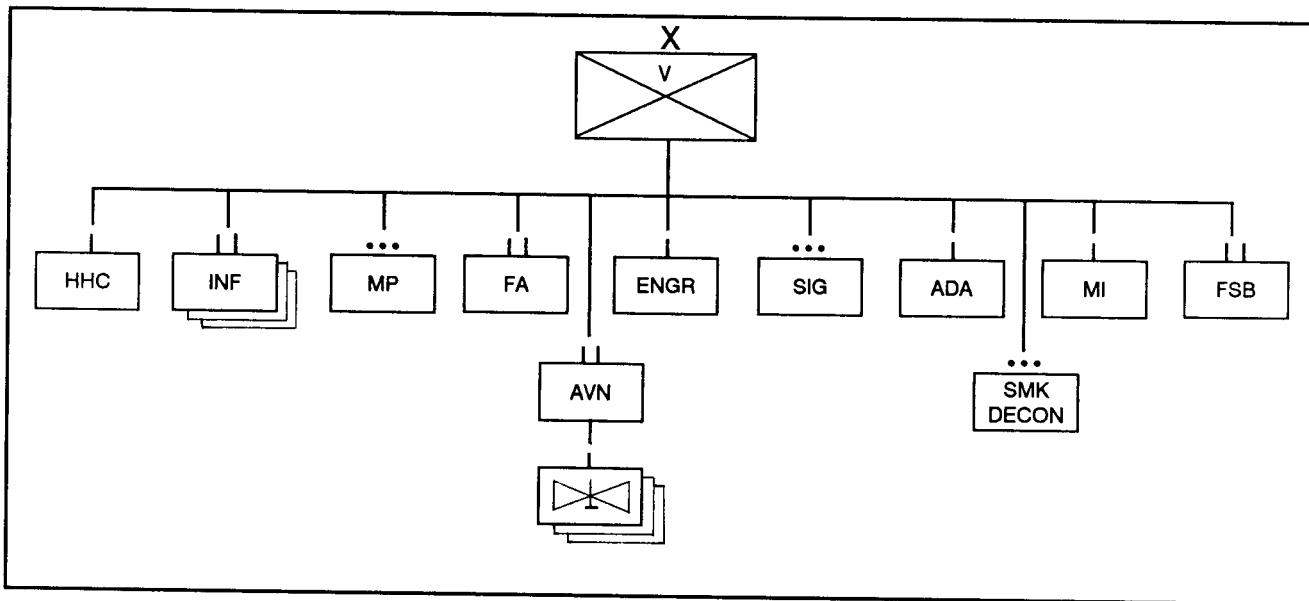

Figure A-2. Example air assault brigade task organization.

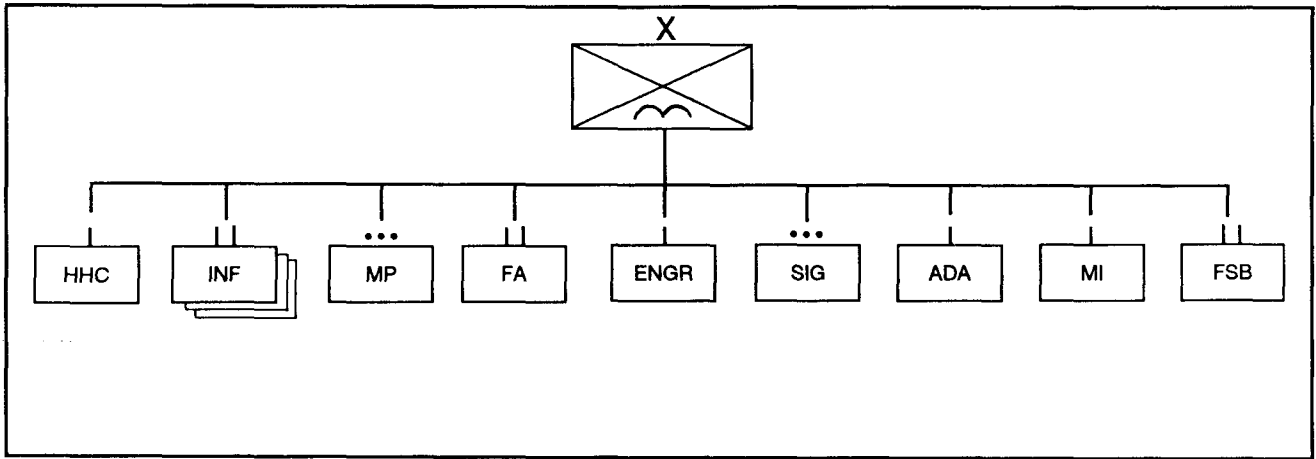

Figure A-3. Example airborne infantry brigade task organization.

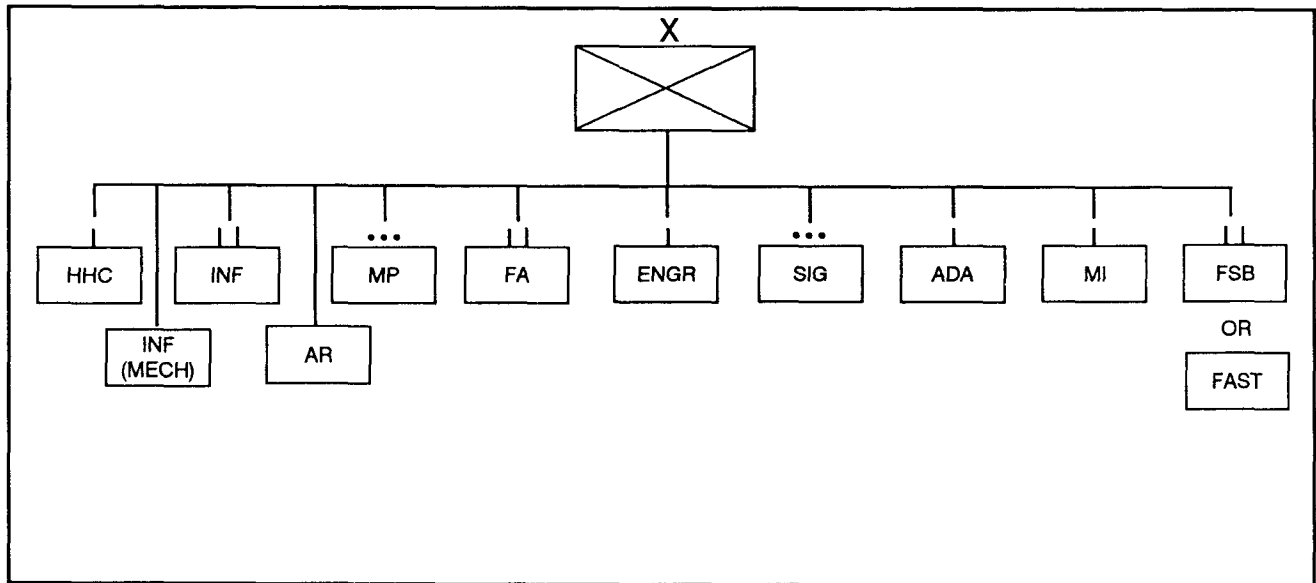

Figure A-4. Example infantry brigade task organization.

A-3. ORGANIZATION OF LIGHT FORCE BATTALIONS

An infantry battalion has a combination of combat, CS, and CSS assets. The battalion HHC contains all CS and CSS assets as well as the reconnaissance and mortar platoons. Depending on the battalion's organization, antiarmor units are either part of HHC or are consolidated in an antiarmor company. (Figures A-5 through A-9 show an example organization of a ranger battalion and of each of the four types of light force battalions.)

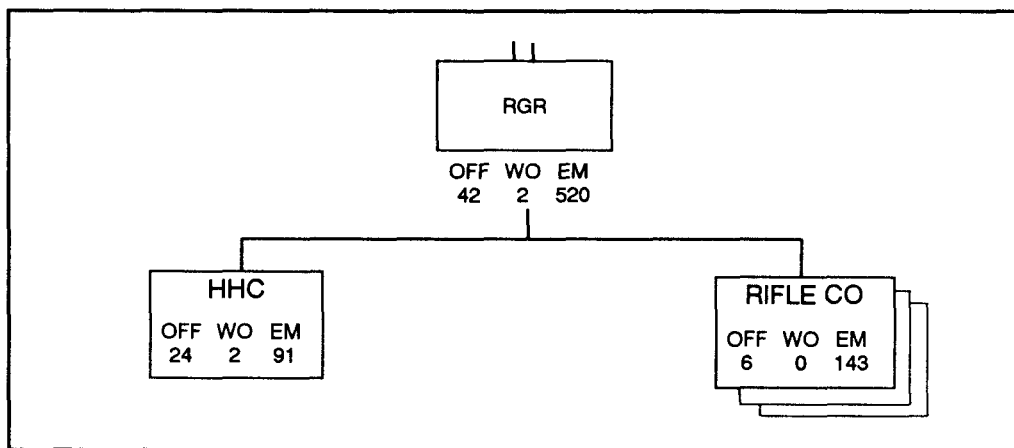

Figure A-5. Example ranger battalion.

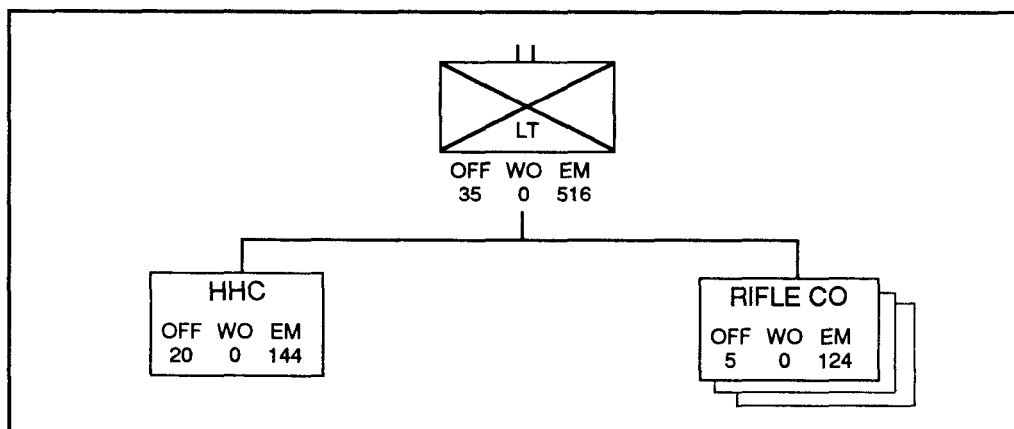

Figure A-6. Example light infantry battalion.

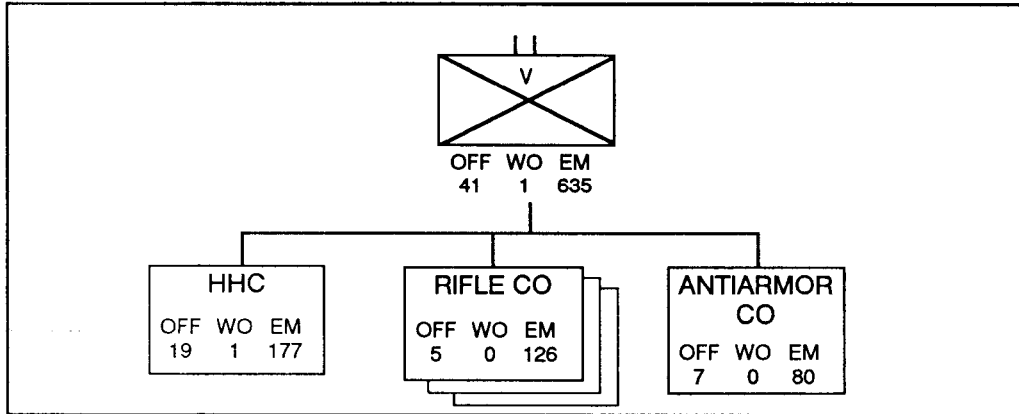

Figure A-7. Example air assault battalion.

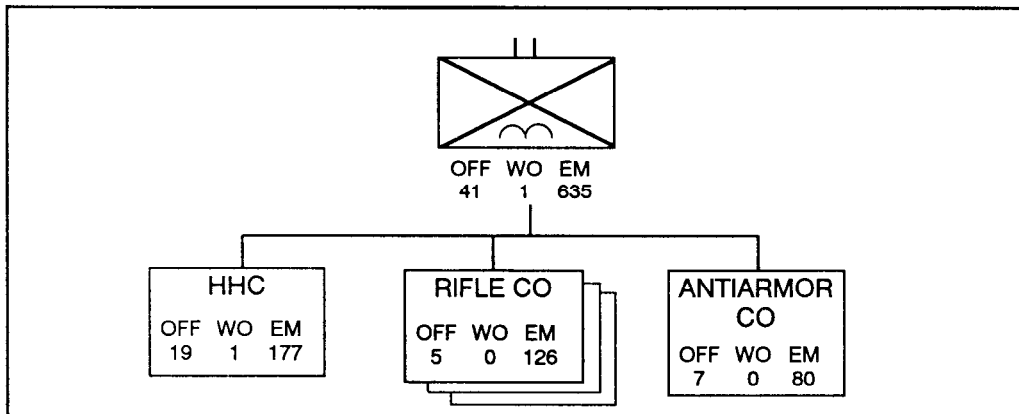

Figure A-8. Example airborne battalion.

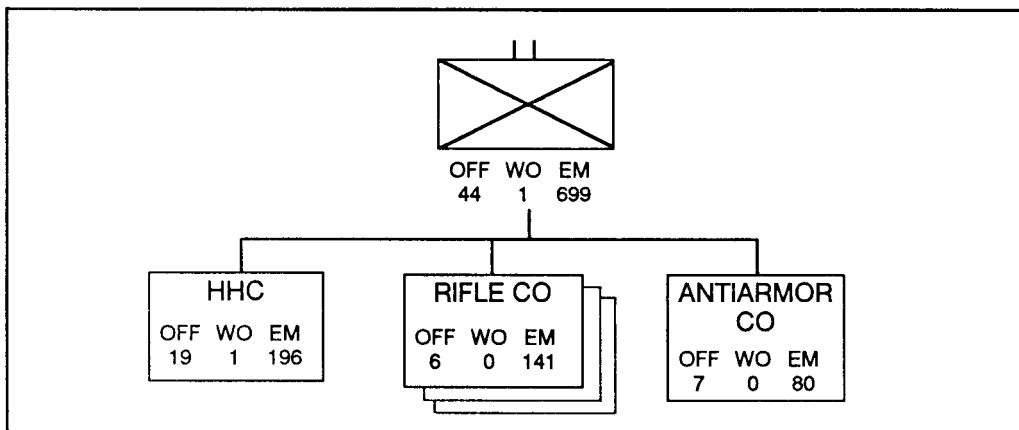

Figure A-9. Example infantry battalion.

A-4. ORGANIZATION OF LIGHT FORCE COMPANIES

The infantry company consists of a combination of nine-man infantry squads, machine guns, mortars, and antiarmor assets. The configuration of these assets depends on the type of organization. (Figures A-10 through A-14 show the organization of ranger companies and each of the four types of light force companies.)

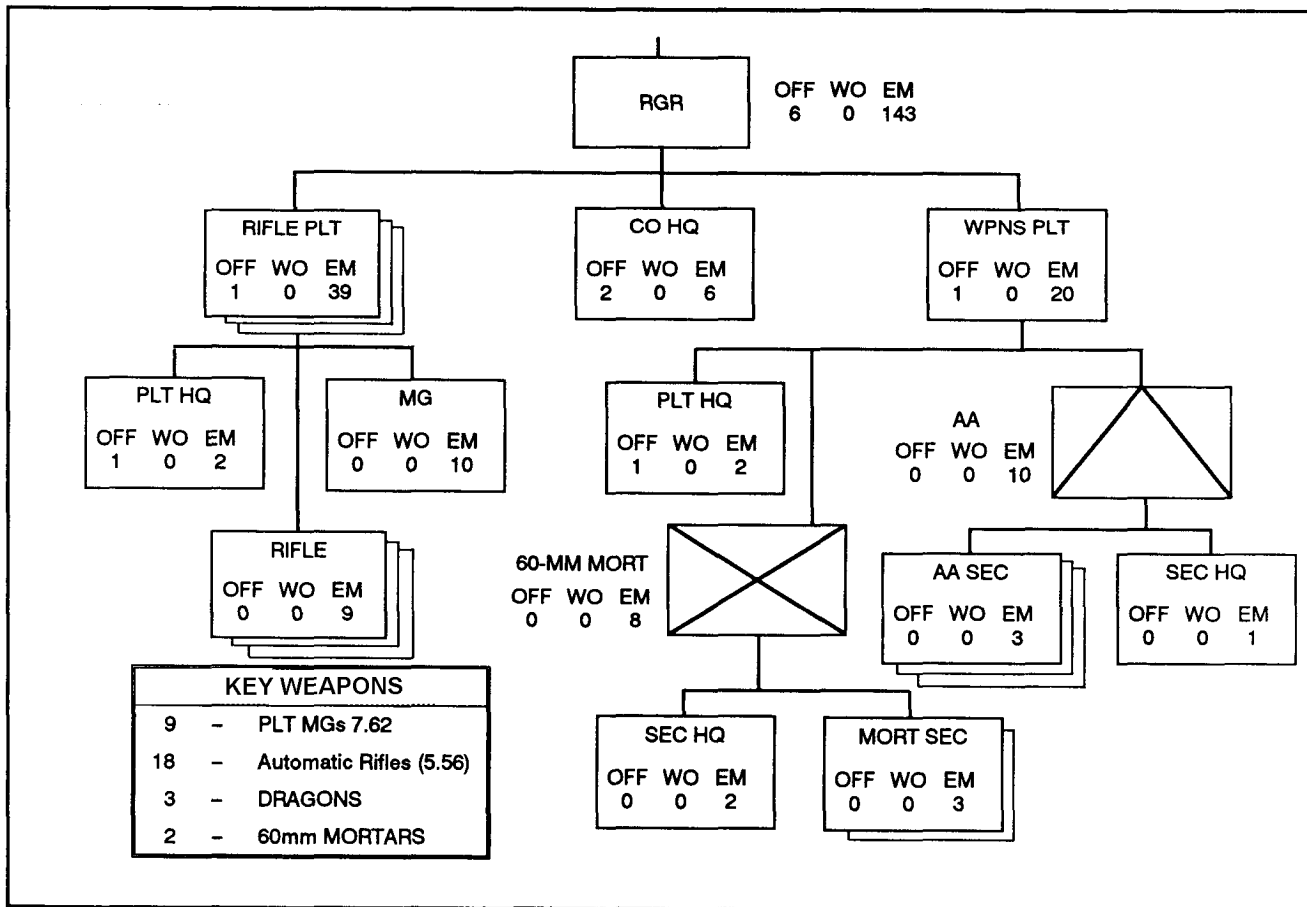

Figure A-10. Example ranger company.

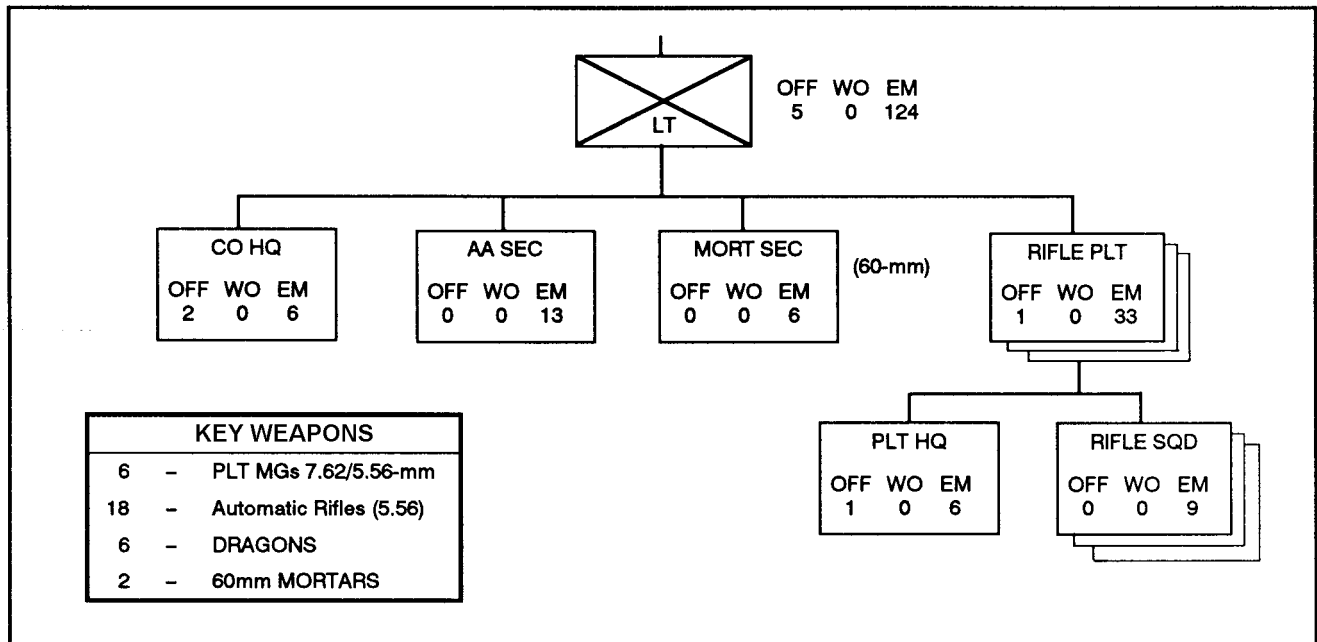

Figure A-11. Example light infantry company.

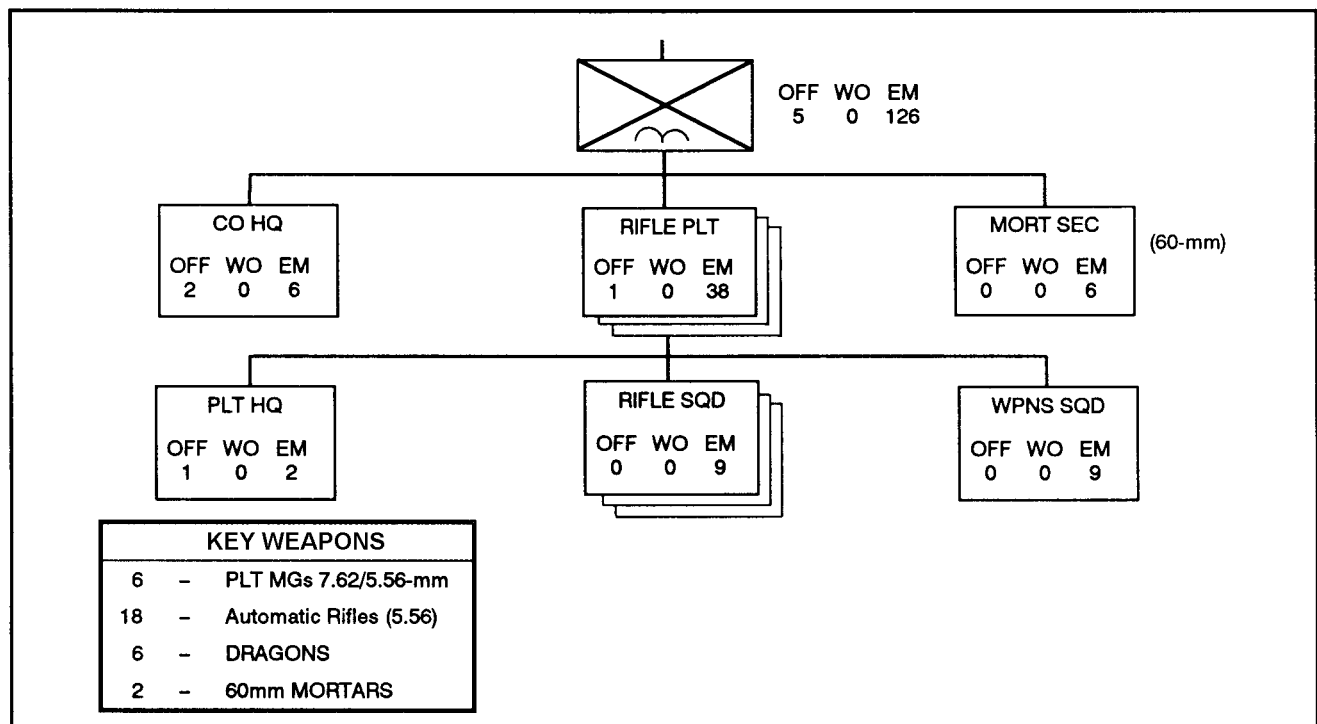

Figure A-12. Example airborne company.

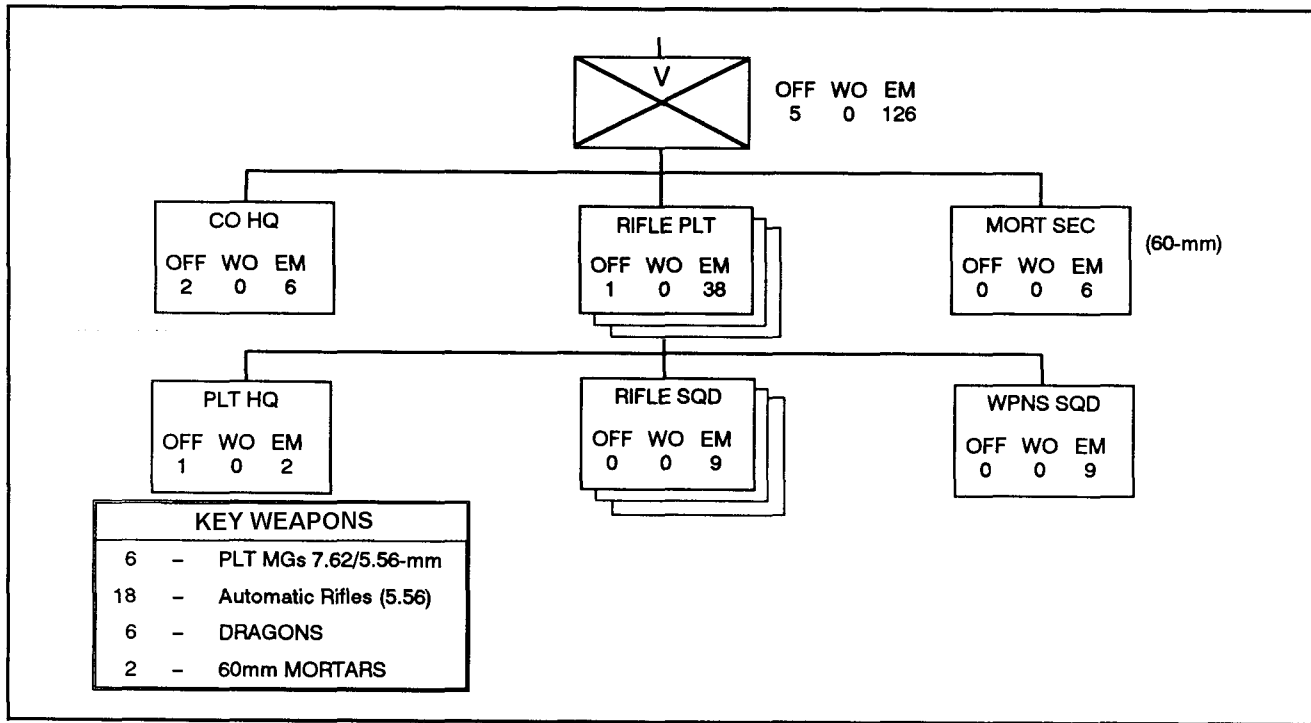

Figure A-13. Example air assault company.

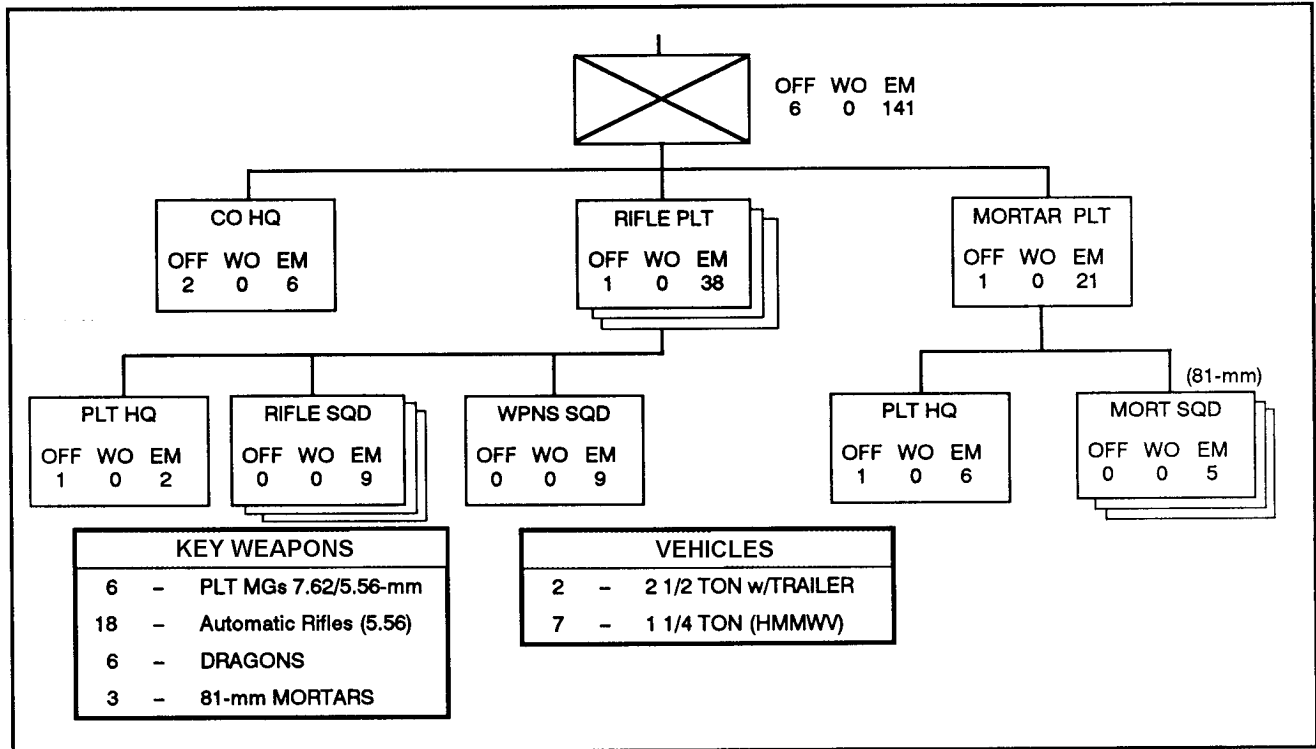

Figure A-14. Example infantry company.

A-5. ORGANIZATION OF SPECIAL OPERATIONS FORCES

Examples of typical SOF organizations include joint operations task forces, ranger regiments, special operations aviation task forces, PSYOP task forces, civil affairs task forces, and special forces operational detachments "A." (FMs 100-25 and 31-20 provide more detailed information.) The basic special forces unit is the special forces operational detachment, A, or SFOD A. This type of unit conducts special operations in denied and remote areas for extended periods, with little external direction and support. The organization of an SFOD A is shown in Figure A-15. The complex structure and high experience level required enable it to develop, organize, equip, train, and advise or direct indigenous military and paramilitary organizations up to battalion size. The SFOD A is best employed as a unit. However, certain operations do not require its full capabilities. For these operations, the SFOD A may be task-organized to provide special forces teams specifically tailored to the requirements of the mission.

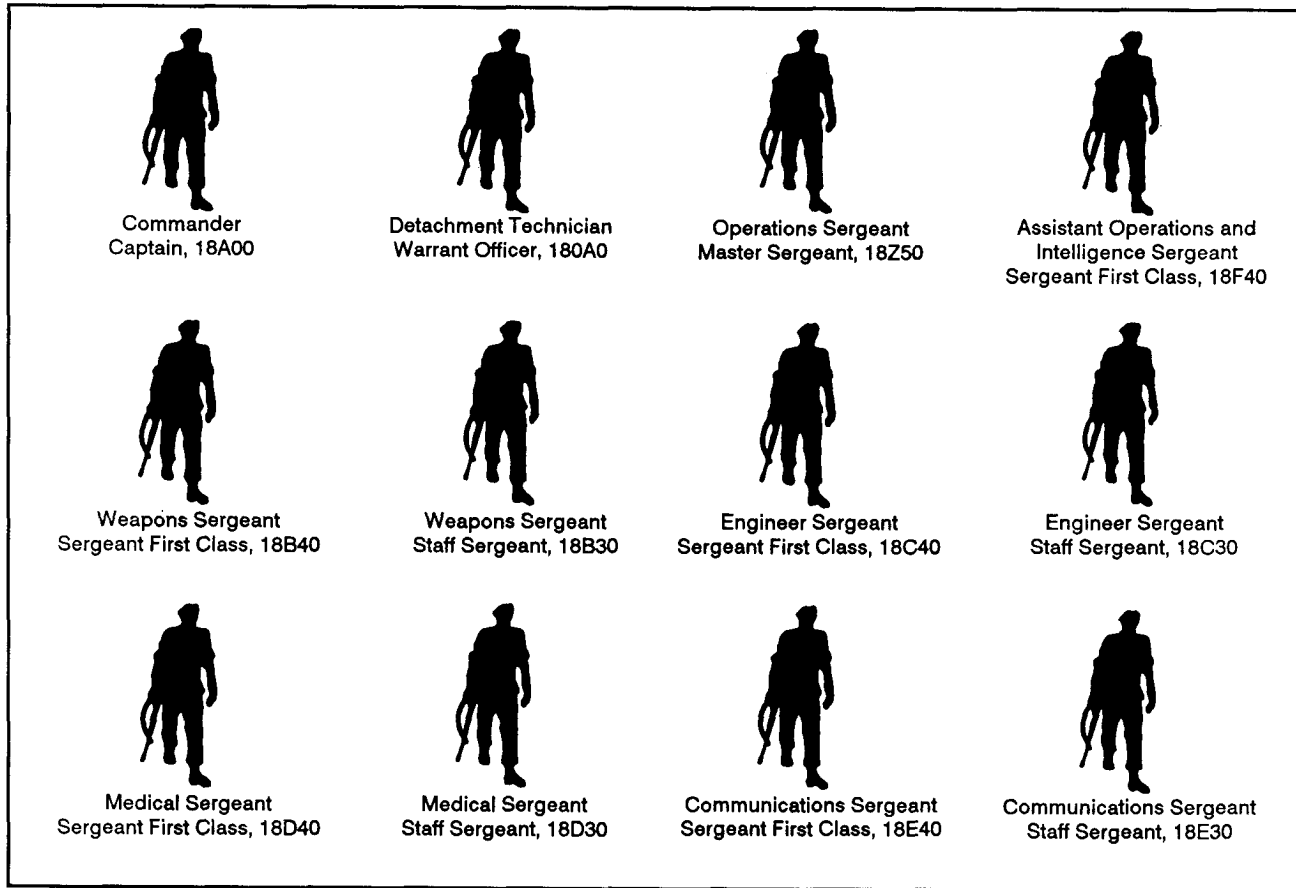

Figure A-15. Special forces operational detachment, A.

A-6. SAFETY CONSIDERATIONS

Mechanized infantry and armored force leaders at all levels must be aware of safety concerns when operating with light forces. Special leader involvement is needed if the infantry unit has received little training with armored vehicles. All personnel must know these safety considerations and remain alert to prevent casualties during light infantry, mechanized infantry, and armored operations.

- a. The armored crew observes enemy locations (or potential locations) rather than nearby soldiers. Infantry soldiers must be alert and maintain a safe position relative to the vehicle.
- b. The high-velocity armor-piercing discarding sabot round presents a safety problem when fired by tanks and the 25-mm gun on the M2/M3. The discarded sabot petals fall to the ground shortly after leaving the muzzle; the danger area extends about 10° below the muzzle level out to at least 100 meters it extends about 17° left and right of the muzzle. Mechanized infantry and armored force leaders must ensure infantry soldiers in this area have rear protection (a berm or tree) and overhead cover.
- c. The exhaust from the M1 tank may cover an angle wider than 60° and may exceed a temperature of 1,700°F. Therefore, soldiers following the tank must move well off to the side of the exhaust grill or, if directly behind the tank, they must remain a safe distance (about 50 feet) from it.
- d. Infantry can ride on top of an armored vehicle. (FM 7-8 discusses the specifics for rigging a vehicle to carry soldiers on top.) However, doing so leaves them vulnerable to enemy fire. Therefore, infantry should ride on a vehicle only when the risk of enemy contact is small and the need for speed is great.

Section II. EMPLOYMENT CONCEPTS

Combining light infantry with mechanized infantry and armored forces gives the brigade commander remarkable flexibility. Using the estimate process, he determines the task organization, the appropriate command or support relationship, the tasks to be accomplished, and the concept of CSS. In missions conducted by this combination of forces, either may be given the main effort. How the commander determines which to use in this role depends on METT-T. He considers such factors as the sizes and types of each force and the support structure available, the expected durations of current and future operations, the type of threat, the type of element that will be most effective on the terrain, and which force has been in the area the longest. A light infantry force combined with a mechanized infantry and armored force can conduct any of the operations neither could conduct alone.

A-7. PLANNING CONSIDERATIONS

Effective employment of a force with mechanized infantry and armored and light elements requires detailed planning. To capitalize on advantages and address concerns, commanders and staffs must plan, rehearse, coordinate, and develop orders for employment. Critical areas include the command and support relationship, the composition of CS and CSS support, and effective use of terrain. Synchronization requires planners to know each unit's capabilities, limitations, and SOPs. Specific planning considerations include the following:

- a. **Intelligence.** Detailed intelligence is critical to integrating light infantry with mechanized infantry and armored forces. Intelligence requirements for each must be understood and integrated into the IPB process. Light forces orient on concentrations of enemy units, enemy infantry avenues of approach, enemy counterattack forces, enemy artillery and air defense assets, and enemy LZs/PZs. The individual force commanders should combine and compare PIR and decision support templates. Then they should explain both in detail to their staffs. Also, commanders should develop reconnaissance and surveillance plans jointly.
- b. **Maneuver.** Either the light force or the mechanized infantry and armored force can fix the enemy. The maneuver force then attacks. In either case, the light force requires the advantage of close terrain.
 - (1) The light force is best suited to close and restrictive terrain, where it can reduce the enemy's mobility and nullify his ability to use long-range weapons and observation assets.
 - (2) The differences between the operational tempos of light infantry and tanks and mechanized infantry must always be considered, as should rehearsal schedules. For both forces to take part, an early rehearsal may be needed.
 - (3) The movement of light infantry must be planned to coincide with darkness, severe weather, smoke, or fog. To help prevent detection, light infantry should move during poor visibility.
 - (4) Direct and indirect fires should be mutually supporting. The mechanized infantry battalion can use its long-range direct fires to provide suppression and overwatch fires for the light brigade.
- c. **Fire Support.** The mechanized infantry and armored force must recognize that dismounted infantry operations focus on stealth, which might not allow for preparatory and other preliminary fires. Fire support available to each force must be integrated into the fire plan. Planners must know the organizations, capabilities, and limitations of all forces involved, particularly their digital and nondigital capabilities. During planning and preparation, a liaison team helps synchronize fire support. Restrictive fire control measures must be jointly developed and understood by everyone.

- d. **Air Defense.** Air defense artillery (ADA) resupply requirements should get special attention. ADA support for combined light infantry and mechanized infantry and armored organizations must be planned centrally. ADA units can be consolidated to provide more dense coverage around critical assets. (Before ADA assets can support light forces in restrictive terrain, resupply must also be consolidated.) The light force must rely heavily on passive air defense measures.
- e. **Mobility/Counter-mobility/Survivability.** A common obstacle plan must be developed. Light forces may be used to clear obstacles and choke points for the mechanized infantry and armored forces. Disparities between weapons' ranges, the impact of these weapons on prepared obstacles, and the use of terrain during battle handover to a mechanized infantry and armored force must all be considered. Survivability remains the priority for light forces. These forces must prepare to take advantage of the engineer assets available to the mechanized infantry and armored forces. When breaching obstacles, light forces must ensure the breach is large enough for the widest vehicle in the operation.
- f. **Combat Service Support.** A mechanized infantry and armored battalion can satisfy the CSS needs of an infantry company more easily than an infantry brigade can satisfy the needs of a mechanized infantry or armored battalion or company.
- (1) **Mechanized infantry and armored battalion, infantry company.** Except for mortar rounds, the mechanized infantry unit can provide all munitions the light infantry company needs. Therefore, the S4 must plan to receive and move 120-mm, 81-mm, or 60-mm mortar munitions.
 - (2) **Infantry brigade, mechanized infantry and armored battalion or company.** Adding a mechanized infantry and armored battalion or company to an infantry brigade significantly increases the fuel, ammunition, and maintenance that must be delivered to the forward area support team (FAST) or to the forward support battalions (FSBs). The infantry brigade lacks the transportation required to support even a small mechanized infantry and armored force, particularly the HETs, for armored vehicle evacuation. The mechanized infantry and armored battalion S4 must constantly project needs to allow the infantry brigade S4 more time to react. Support packages may be required for the mechanized infantry or armored element attached to the light force. The preferred method of attachment is OPCON. This relationship permits the mechanized infantry or armored battalion to continue receiving support from its FSB. The support package may need to include fuel, heavy expanded-mobility tactical trucks (HEMTTs) and operators, HETs with drivers, tracked ambulances, and maintenance support teams (MSTs).
- g. **Command and Control.** The directing headquarters designates the command relationships within the light infantry and mechanized infantry and armored

forces. Generally, the preferred relationship is a light infantry battalion *attached* to a mechanized infantry or armored brigade. However, when a mechanized infantry and armored battalion is tasked to a light infantry brigade, the preferred relationship is *OPCON*. Either way, they exchange liaison officers. LOs plan jointly and coordinate the development of orders and overlays. Briefbacks are required at the brigade level of all combat, CS, and CSS units; this ensures timing, synchronization, and understanding of intent. Standard operational terms and symbols must be used; codes, recognition signals, and SOI are exchanged. The directing headquarters may need to set up a retransmission site to compensate for the shorter range of the light unit's communications equipment.

- h. **Nuclear, Biological, Chemical.** The light force lacks decontamination equipment and, therefore, is more limited in an NBC environment than the mechanized infantry and armored force. The mobility of the light force is affected by the soldiers' need to carry protective clothing in addition to their standard loads. When higher headquarters cannot provide transportation assets, planners should arrange for mechanized infantry and armored unit vehicles to help transport light force NBC equipment. Also, a mechanized infantry and armored battalion has expedient devices and water-hauling capabilities that can be used to offset light force shortfalls. Transporting these items with mechanized or armored assets reduces the load of light infantry units. Commanders must consider METT-T and must plan linkup points to ensure the light unit obtains these critical items as they need them.

A-8. OFFENSIVE OPERATIONS

The fundamentals, principles, and concepts discussed in Chapter 3 apply to light infantry as well as to mechanized infantry and armored offensive operations. However, this combination can work many different ways in the offense. The following are some of the basic ones:

- a. **Mechanized Infantry and Armored Force Support, Light Force Assault.** With this method, tanks and BFVs attack by fire while the infantry assaults the objective. The vehicles tire from hull-defilade positions until the infantry masks their fires. This is the most effective method for BFVs; it may also be used with tanks when antitank weapons or obstacles prohibit them from moving to the objective.
 - (1) This method may incorporate a feint to deceive the enemy as to the location of the main attack. If so, the mechanized infantry and armored force supporting attack by fire is timed to divert the enemy's attention from the light force's assault. The fires of the mechanized infantry and armored force may also cover the sound of the infantry's approach or breach. Close coordination between the mechanized infantry and armored commander and the light force commander is vital for effective fire control.

- (2) This method may vary when either the terrain or the disposition of the enemy limits the mechanized infantry and armored forces' ability to support the infantry's attack by fire. In this case, the mechanized infantry and armored force may be tasked to suppress or fix adjacent enemy positions, or to accomplish other tasks to isolate the objective area.
- b. **Simultaneous Assault.** With this method, light and mechanized infantry and armored forces advance together, and infantry and vehicles move at the same speed. The vehicles may advance rapidly for short distances, stop and provide overwatch, then move forward again when the infantry comes abreast. Tanks are best suited to assault under fire. Mechanized infantry vehicles may also be used in this manner, but only when the threat of antitank fires is small. If an antitank threat exists, infantry usually leads; the vehicles follow to provide fire support.
- (1) This method may be used when the enemy situation is vague, when the objective is large and consists of both open and restrictive terrain, or when visibility, fields of fire, and the movements of the mechanized infantry and armored force are restricted. These conditions exist in fog, at night, in towns, and in woods. The vehicles provide immediate close direct fires, and the infantry protects the vehicles from individual antitank measures.
 - (2) This method sometimes requires infantry to follow a safe distance behind the tanks for protection from frontal fires. This is true when the main enemy threat is small-arms fire. From behind the tanks, the infantry can protect the flanks and rear of the tanks from handheld antitank weapons.
 - (3) This method may require light and mechanized infantry and armored forces to advance together in operations that require long, fast moves. Infantrymen ride on the armored vehicles until they make contact with the enemy. Though this is a quick way to move, it exposes infantry to enemy fire, particularly to airburst munitions. Also, it interferes with the operation of BFVs and tanks.
- c. **Assault from Different Directions.** With this method, mechanized infantry and armored forces and light forces converge on the objective from different directions. BFVs, tanks, and light infantry advance by different routes and assault the objective at the same time. For this synchronization to succeed, the infantry elements must maneuver and close on their assault position under cover of darkness or poor weather. The synchronization of the assault provides surprise, increases fire effect, and maximizes shock action. Planning, disseminating, and rehearsing the coordination of direct-fire and indirect-fire measures are critical in this type of operation.
- (1) This method is effective when tanks are used and may be used when two conditions exist: First, terrain must be at least partly open and must be free from mines and other tank obstacles. Second, supporting fires and smoke must effectively neutralize enemy antitank weapons during the

brief period required for the tanks to move from their assault positions to the near edge of the objective.

- (2) This method requires that light and mechanized infantry and armored forces coordinate to provide effective fire control on the objective. When conditions prohibit the armored vehicles from advancing rapidly, infantry should accompany them to provide protection.

d. **Mechanized Infantry and Armored Force Support/Assault, Light Force Assault.** With this method, the mechanized infantry and armored force attacks by fire, then moves forward rapidly and joins the light forces for the assault. Once the light infantry has moved into an assault position, armored vehicles begin by suppressing the objective from hull-defilade positions. When the light infantry masks the vehicle fires or when the commander gives the signal, the mechanized infantry and armored force moves forward rapidly and joins the infantry in the final assault.

- (1) This method should only be used with tanks. It should only be used with other armored vehicles when little antitank threat exists. Armored vehicles that cannot assault with the infantry can be used to isolate the objective area; once the objective is secured, the armored vehicles support the consolidation of the objective. During the assault, the tanks may move with or slightly ahead of the infantry.
- (2) This method is used when the enemy has prepared obstacles on the mounted avenues of approach. The infantry seizes a foothold and secures multiple lanes through obstacles to allow the mechanized infantry and armored force access to the objective. This method exposes tanks to enemy fire for a shorter time than do the other three methods. With this method, tanks can move forward at their own speed. Also, enemy fire directed at the friendly tanks does not endanger the infantry. This may be the best method to use to give the infantry the chance to approach the objective undetected.
 - (a) With two different forces assaulting, actions within 300 meters of the objective are critical. In this area, the infantry is the most exposed to the largest number of well-sited weapons and intense direct and indirect fires. Therefore, enemy positions must themselves be subjected to a continuous, high-volume of direct and indirect fires. Enemy mortars must be targeted and attacked by indirect fire or CAS. Supporting fires must range the width and depth of the objective but, to avoid fratricide, must not be placed on the obstacles to be breached. Speed is critical, as is separation of infantry and armored vehicles in the breach lanes and on the objective.
 - (b) Time must be spent during rehearsals to coordinate actions on the objective to ensure a synchronized assault. These actions include supporting fires, breach markings, signals, and control measures. At the conclusion of actions on the objective, armored vehicles should move quickly to positions that facilitate consolidation.

A-9. OFFENSIVE MISSIONS AND ROLES

The firepower, mobility, and shock effect of the mechanized infantry and armored force are integrated with the dispersed and synchronized attacks of the light forces during offensive operations. Tables A-1 and A-2 show missions and roles that the mechanized infantry and armored battalion, and the light infantry company, conduct in offensive operations.

BATTALION TASK FORCE MISSION	ROLE OF LIGHT INFANTRY COMPANY
Movement to contact	Clear and secure restrictive areas. Assault by air to fix or create weakness. Reconnoiter. Conduct a deception. Establish contact points for linkup.
Attack	Reconnoiter. Suppress antitank weapons. Conduct a deception. Breach obstacles. Suppress and destroy obstacles. Reduce strongpoint. Provide security. Assault by air to seize objectives. Seize and secure restrictive terrain. Create weaknesses in enemy defense. Obstruct enemy command, control, and communications capabilities. Attack by fire. Establish roadblocks.

Table A-1. Mechanized Infantry and armored battalion, light infantry company, offense.

LIGHT INFANTRY BRIGADE MISSION	ROLE OF BATTALION TF
Movement to contact	Overwatch likely enemy avenues of approach. Provide attack-by-fire force. Overwatch and help reduce obstacles. Defend a moving force. Provide a covering force, guard, or both. Provide a counterattack force.
Attack	Provide suppressive fires. Isolate the objective. Counterattack. Provide initial hasty defense during consolidation. Attack by fire. Exploit or reinforce success. Overwatch counterattack routes on objective. Conduct a deception. Help in assault breach. Provide a reserve or exploitation force. Support by fire. Provide a lead force. Provide mounted reconnaissance.

Table A-2. Light infantry brigade, mechanized infantry and armored battalion or company, offense.

A-10. EXPLOITATION

Exploitation follows success in battle. The mechanized infantry and armored force is usually the most capable exploitation force. It takes full advantage of the enemy's disorganization by driving into the enemy's rear to destroy and defeat him. A tank-heavy force operating as a team may exploit the local defeat of an enemy force or the capture of an enemy position. The purpose of this type of operation is to prevent reconstitution of enemy defenses, to prevent enemy withdrawal, and to secure deep objectives. A common combination is the mechanized infantry and armored force battalion reinforced by an attached infantry company, engineers, and other supporting units. The infantry may be transported in armored vehicles or trucks or may ride on the tanks. Riding on tanks reduces road space, decreases supply problems, and keeps the members of the team together. Infantry leaders ride with the corresponding tank unit commanders. Depending on METT-T conditions, this may be the best way to move the team. However, firing a main gun or cannon at an unexpected enemy would probably injure passengers riding on top of the vehicle. Therefore, the commander must first weigh the likelihood of enemy contact against the need for speed.

A-11. DEFENSIVE OPERATIONS

Light infantry and mechanized infantry and armored forces are well suited to conduct defensive operations. The mechanized infantry and armored force provides a concentration of antiarmor weapons and the capability to rapidly counterattack by fire or maneuver. The light force can occupy strongpoints, conduct spoiling attacks, and conduct stay-behind operations. The fundamentals, principles, and concepts discussed in Chapter 4 apply also to combined light and mechanized infantry and armored defensive operations. Techniques are as follows:

- a. **Mechanized Infantry and Armored Force Forward, Light Force in Depth.** With this method, the mechanized infantry and armored unit covers forward of a light unit's defense, masking the location of the light unit. While passing through the light unit's positions, mechanized infantry and armored units provide most of their own overwatch protection. Careful planning is required for battle handover to the light unit. Light unit direct-fire overwatch weapons are scarce that support from inside the battle handover line. To solve this problem, some mechanized infantry and armored force antiarmor assets can be provided to the light infantry. Usually, these assets are provided only at company level and above.
- b. **Light Force Forward, Mechanized Infantry and Armored Force in Depth.** With this method, the mechanized infantry and armored force assumes positions in depth behind the light unit's defense. The light unit's forward deployment shapes the battlefield for decisive action by the mechanized infantry and armored forces. The light unit leaves an avenue of approach into the mechanized infantry and armored unit's engagement area; at the same time, the light unit prevents the enemy from using restrictive terrain. If the enemy penetrates the light unit, the mechanized infantry and armored unit counterattacks, destroying or blocking the enemy until additional units can be repositioned to destroy him. To support this counterattack, the light unit identifies the location of the enemy's main effort, slows his advance, and destroys his command, control, and CS elements. The light unit can also guide the counterattacking force through restrictive terrain to surprise the enemy on his flank.
- c. **Light Force Terrain-Oriented, Mechanized Infantry and Armored Force Enemy-Oriented.** Terrain-oriented refers to area defense, and enemy-oriented refers to mobile defense. With this method, the entire force defends along the FEBA. The light force, whether used as a flanking or covering force or positioned in depth, emplaces its elements to best use restrictive terrain. The mechanized infantry and armored force keeps its freedom of maneuver. To protect the light unit, contact points between light and mechanized infantry and armored units should be in restrictive terrain. Also, a light unit may defend to hold terrain while the tanks and BFVs maneuver to destroy the enemy from the flanks or rear.

- d. **Strongpoint.** With this method, the light unit, along with additional assets, occupies a strongpoint. The enemy is then forced into the mechanized infantry and armored units' engagement area.
- e. **Stay-Behind Operations.** With this method, the light unit occupies hide positions well forward of the FEBA. As the enemy passes, the light forces attack the enemy's command, control, CS, or CSS elements. The mechanized infantry and armored force defends against enemy maneuver forces.

A-12. DEFENSIVE MISSIONS AND ROLES

Tables A-3 and A-4 show the missions and roles of light and mechanized infantry and armored forces in defensive operations.

BATTALION TASK FORCE MISSION	ROLE OF LIGHT INFANTRY COMPANY
Defend	Block or fix likely dismounted approaches. Occupy positions in depth. Block mounted infiltration routes in restrictive terrain. Occupy strongpoints. Provide security. Conduct counterreconnaissance. Set up observation posts. Conduct ambushes. Provide antiarmor ambush teams. Conduct air assault to counter rear threat. Conduct spoiling attack raids and provide reaction forces to counter enemy reconnaissance. Conduct military operations on urbanized terrain (MOUT). Reconnoiter to identify engagement areas and locations of friendly obstacle positions. Defend obstacles against enemy reconnaissance units. Create weaknesses in the enemy attack.

Table A-3. Mechanized infantry and armored battalion, light infantry company, defense.

LIGHT INFANTRY BRIGADE MISSION	ROLE OF BATTALION TF
Defend	Defend Counterattack to restore integrity of the defense. Cover obstacles with long-range direct fire. Deceive enemy about main defense. Provide a covering or security force. Provide a reserve or exploitation force. Conduct counterreconnaissance.

Table A-4. Light Infantry brigade, mechanized Infantry and armored battalion or company, defense.

A-13. RETROGRADE OPERATIONS

Retrograde operations include delays and withdrawals, which help gain time and avoid decisive action. Mechanized infantry and armored forces are employed against the enemy forces and avenues of approach that most threaten the operation. To move to subsequent positions, light forces need additional transportation assets, including helicopters. Basic movement techniques include maneuver and a reverse bounding overwatch. Mechanized infantry and armored units with small, light force units, mounted along with infantry reconnaissance platoons and antitank elements, move to subsequent delay positions under the cover of mutually supporting forces.

A-14. RETROGRADE MISSIONS AND ROLES

Tables A-5 and A-6 list missions and roles for retrograde operations.

BATTALION TASK FORCE MISSION	ROLE OF LIGHT INFANTRY COMPANY
Delay	Delay along likely infantry avenues of approach (need mobility assets to move quickly). Reconnoiter and prepare delay routes. Reinforce at subsequent delay positions. Use limited counterattacks to aid in disengagement. Help with obstacles planned and executed in depth. Occupy stay-behind positions.
Withdrawal	Establish in-depth positions and obstacles. Provide an air assault to deceive the enemy, cause him to pause in his maneuver, or both.

Table A-5. Mechanized Infantry and armored battalion, light infantry company, retrograde.

LIGHT INFANTRY BRIGADE MISSION	ROLE OF BATTALION TF
Delay	Overwatch. Counterattack by fire. Deceive the enemy. Reinforce. Reposition rapidly to prevent a bypass. Reserve.
Withdrawal	Deceive the enemy. Fix the enemy attack. Provide a detachment left in contact (DLIC). Provide a rear guard. Occupy in-depth positions. Reserve.

Table A-6. Light infantry brigade, mechanized infantry and armored battalion, retrograde.

Section III. INTEGRATION AND SYNCHRONIZATION OF SPECIAL OPERATIONS FORCES

Special operations forces (SOF) frequently operate along with conventional forces, preceding them into the area of operations. Contact between them occurs only for the purpose of extracting the SOF or passing responsibility.

A-15. SPECIAL OPERATIONS COMMAND AND CONTROL ELEMENT

The SOF report to a special operations command and control element (SOCCE). The main task of the SOCCE is to synchronize, rather than integrate SOF with conventional forces. This is crucial in prolonged contact with the enemy.

- a. **Level of Authority and Responsibility.** The SOCCE's level of authority and responsibility varies. For example, when directed, it controls SOF operational elements during specific missions such as linkups. If SOCCE's mission exceeds its organic capabilities, it may be augmented by other assets assigned to the Army special operations task force (ARSOTF).
- b. **Operational Level.** The level at which a SOCCE operates also varies. In times of war, it normally operates at corps level or above. During contingency operations, divisions or independently operating brigades may be provided with a SOCCE. However, when SOF and conventional forces operate near each other, the SOCCE may work down to divisional brigade level, with smaller liaison teams at battalion level.
- c. **Support Requests.** The conventional force commander must request a SOCCE as soon as he identifies the need to synchronize or physically integrate SOF. The joint force commander coordinates the deployment of the SOCCE.
- d. **Linkup Procedures.** When SOF are to operate in the task force's area of operations or interest (AO or AI), the SOF headquarters controlling SOF forces exchange liaison officers with the task force.
- e. **Functions.** The SOCCE performs the following functions:
 - (1) Establishes a cell at the supported unit's CP and operates the cell continuously.
 - (2) Advises the *supported* conventional force commander on employment, missions, terrain management, current situation, capabilities, and limitations of the *supporting* SOF units. Participates in the *supported* unit's development of the estimate of the situation and concept of operations.
 - (3) Advises the *supporting* SOF commander of the *supported* conventional force commander's situation, intentions, and requirements.

- (4) Provides required communication links. However, elements attached to a SOCCE or Ranger liaison team must provide or coordinate their own secure communications.
- (5) Synchronizes special operations with conventional force operations and intelligence requirements. Pays special attention to doing so in such a way as to avoid fratricide.
- (6) Coordinates conventional force *support* for the special operations.
- (7) Receives SOF operational, intelligence, and target acquisition reports from deployed SOF elements and provides them to the conventional force commander and staff.
- (8) When linkup becomes imminent, assists the staff of the conventional force in planning the linkup.
- (9) Provides SOF locations to the FSE and brigade operations section through personal coordination, overlays, and other friendly order-of-battle data.
- (10) Requests appropriate restrictive FSC measures and provides windows for the times when these measures are to be effective. Ensures that FSE dissemination of these measures does not violate OPSEC.

A-16. EMPLOYMENT OF SPECIAL OPERATIONS FORCES

The SOF may provide the following information and aid to the mechanized infantry and armored forces:

- Enemy movement patterns within an area of operations.
- Cultural background information.
- Communication with the indigenous population.
- Communication with other US agencies within the area of operations.
- Civil affairs guidance.
- Limited PSYOP support.

A-17. MECHANIZED INFANTRY BATTALION TASKS

Commanders may task mechanized infantry battalions to perform the following when operating with SOF:

- a. Provide extra combat power to an SOF-supported indigenous combat force or to a host nation force during counterinsurgency operations.
- b. Provide a reaction force or reinforcements to SOF during direct action or special reconnaissance operations.
- c. Link up with SOF and relieve them in place (Chapter 6).

- d. Deny enemy access to or reinforcements of areas where SOF are operating.
- e. Provide support to civil affairs and PSYOP personnel.

Section IV. MILITARY OPERATIONS ON URBANIZED TERRAIN

Towns or other urban areas are considered restrictive terrain, so close teamwork between mechanized infantry and armored forces and light infantry forces is critical. The battalion commander and S3, when developing the scheme of maneuver, should consider whether the SOF are working in the same area with conventional forces. Company teams may be used to encircle an enemy force operating in a town, to penetrate the enemy's outer defenses, or to fight house-to-house within the town (MOUT). (FM 90-10-1 provides more information.)

A-18. RESTRICTIONS ON ARMORED VEHICLES

The effectiveness of armored vehicles that operate inside the built-up area is degraded; the vehicles are vulnerable to enemy ambush. Armor protection is offset by the close-range of engagement. The ability of armored vehicles to acquire targets, the effectiveness of their long-range fires, their speed, and their mobility are restricted on urbanized terrain. Also, handheld antitank weapons or explosives employed from the roofs or upper floors of buildings can easily penetrate the top of armored vehicles.

A-19. ROLE OF INFANTRY

Operations conducted on urbanized terrain are fought mainly with infantry. Though armored vehicles can be effective when used as mobile fire support assets, their survival requires close infantry support. As a result, the armored force is usually task-organized into infantry-heavy company teams. Mechanized infantry and armored sections in a MOUT environment are also commonly task-organized to an infantry platoon.

A-20. LIGHT AND MECHANIZED INFANTRY AND ARMORED OPERATIONS

Commanders plan light infantry battalion, mechanized infantry and armored company operations the same for a MOUT environment as for any other terrain. If possible, the mechanized infantry and armored force is employed where it has the greatest potential for offensive maneuver. In some situations, tanks and BFs may be used exclusively around the perimeter of the town. They

can operate outside a small town or village and still provide adequate fire support to the infantry.

A-21. OFFENSIVE CONSIDERATIONS

The task force conducts a light infantry battalion, mechanized infantry and armored company attack by isolating the area, seizing a foothold, and clearing an area.

- a. The mechanized infantry and armored force can help with each of these steps. Its offensive role in MOUT is as follows:
 - (1) **To isolate the area.** The area to be isolated may be an entire village or small town, or it may be part of a larger built-up area. The mechanized infantry and armored force is usually effective during this isolation phase. It can operate outside the town, using its long-range fires, speed, and mobility. A defender often initially positions much of his force outside the town (to disrupt an attack, limit reconnaissance, and prevent bypass). However, the mechanized infantry and armored force may prevent these enemy elements from withdrawing back into the town. For the isolation plan to work, it must support the next step seizure of a foothold. After the objective has been isolated, task organization may be changed to provide armored vehicle support to each infantry company within the town.
 - (2) **To seize a foothold.** The mechanized infantry and armored force can also support this phase of the operation. It uses the sights and thermal viewers of its armored vehicles to conduct an initial long-range reconnaissance. In this way, the mechanized infantry and armored force may provide the best means for locating enemy positions, vehicles, or both during limited visibility. Once the enemy's weak points have been located, the armored vehicles can provide fire support for infantry assaulting to secure the foothold. The infantry conducts their assault like any other light and mechanized infantry and armored assault. As an option, the mechanized infantry and armored force (or a part of it) may divert the enemy's attention away from the point of the main attack. Vehicles with an on-board smoke capability can provide concealment for the infantry assault.
 - (3) **To clear the objective.** The armored vehicles continue, once the infantry has seized a foothold, to provide close supporting fires while the infantry clears each building. Because of the danger of ambush, tanks do not move ahead of the infantry but provide fire support from positions already cleared. In fact, armored vehicles may be able to continue providing fire support without entering the town. If any armored vehicles do operate within the town, they must be closely controlled by the infantry leader. Target identification and fire control measures change rapidly as clearing progresses. Armored vehicles provide suppressive fires

to enable the infantry to establish a foothold in each building. Then the armored vehicles isolate the building by engaging known or suspected enemy locations. Once the infantry is inside the building, the armored vehicles continue to suppress other floors within the building or to shift their fires to adjacent buildings.

- (a) Visual signals are the most effective and reliable means of communication between the infantry force and the armored vehicles. Targets can be identified with tracer fire, smoke rounds fired from grenade launchers, smoke grenades, or arm-and-hand signals. Specific actions initiating, lifting, or shifting fires; moving forward to the next position; or providing smoke obscuration can be directed in a similar manner.
- (b) Communications between the armored vehicles and the infantry leader may be by FM radio or landline. However, the terrain may interfere with radio communications. Landlines should be used only when the leader can operate while walking behind the vehicle. To use landlines, soldiers must run the wire to the inside of the vehicle through the hatch to the binding post on the AM-1780 or to the binding post terminals on the right rear deck of the M2/M3. The leader then uses TA-ls to relay fire control instructions from the assaulting infantry force to the tank commander.

b. Specific mechanized infantry and armored force actions include the following:

- (1) Firing into the upper stories of buildings to drive the enemy to the basement, where the infantry can trap and destroy him.
- (2) Suppressing and destroying enemy weapons and personnel, allowing infantry to maneuver.
- (3) Providing protection for other antitank systems.
- (4) Creating openings in walls and reducing barricades with cannon fire, giving soldiers access to buildings.

A-22. DEFENSIVE CONSIDERATIONS

Mechanized infantry and armored forces defending in a MOUT environment have the same weaknesses as attacking forces. They also require the close support of infantry forces. Mechanized infantry and armored forces can support the infantry defense of an urban area by defending or delaying forward of the town, fighting a mobile battle around the town, or defending within the built-up area along with the infantry.

- a. **Fighting Forward of the Built-Up Area.** A mechanized infantry and armored force can either delay the enemy, disrupt his attack, or prevent him from conducting a timely reconnaissance of the defenses within the town. They can delay the enemy while defenses within the town are completed. After

this, they may withdraw into defensive positions that are either integrated into the MOUT defense or positioned outside the town to prevent the enemy from enveloping or bypassing the town. A mechanized infantry and armored force fighting outside the town requires infantry augmentation.

- b. **Fighting on the Perimeter of the Built-Up Area.** A mechanized infantry and armored force fighting on the perimeter of a built-up area may find and use terrain suitable to its capabilities. From the perimeter, this force can also prevent the enemy force from isolating all or part of the town. Conducting spoiling attacks or counterattacking against enemy forces may also be easier. Before conducting a counterattack, the mechanized infantry and armored force may occupy a concealed location outside the built-up area to avoid detection. It can produce decisive results if it prevents the enemy from seizing a foothold or if it times the counterattack for when part of the enemy's force starts clearing into the built-up area.
- c. **Fighting Within the Built-Up Area.** A mechanized infantry and armored force may be employed as fire support for infantry positions or strongpoints or, where the terrain allows, as a mobile defense. Defenses may be shaped to draw the enemy into position where part of his forces can be destroyed or cut off by a mobile mechanized infantry and armored force counterattack. Depending on the type of construction in the built-up area, armored vehicles may reduce buildings to rubble or may burn them to clear routes for movement. When used for direct-fire support of infantry positions or in highly restrictive, armored vehicles operate most often in sections. For short periods, they may operate as individual vehicles.

APPENDIX B

COMBAT ORDERS

Practical planning and timely preparation and distribution of simple, direct orders; use of proper overlay symbology; and implementation of a standard reporting system are key factors in the success of any military operation. Combat orders set forth the details of tactical operations and administration in the field. They may be issued initially as a plan to become an order at a specified time, or as stated contingencies arise. The commander and staff must understand that warning orders and fragmentary orders are the normal means of communicating in combat. The battalion task force tactical SOP can greatly reduce the verbiage in a written order and expedite staff actions in planning.

CONTENTS		
PARAGRAPH		PAGE
Section I.	TYPES AND CHARACTERISTICS OF COMBAT ORDERS	B-2
B-1	Types of Combat Orders	B-2
B-2	Essential Characteristics	B-4
Section II.	FIVE-PARAGRAPH FIELD ORDER FORMAT	B-4
B-3	Designation of Task Forces and Teams.	B-4
B-4	Direction	B-5
B-5	Date-Time Group	B-5
B-6	Time Zone	B-5
B-7	Format	B-5
B-8	Overlays	B-17
B-9	Task Force Execution Matrix	B-18
B-10	Construction of an Execution Matrix	B-18
Section III.	DEFENSE OPERATIONS ORDERS	B-19
B-11	Warning Order	B-19
B-12	Five-Paragraph Field Order	B-21
B-13	Fragmentary Order	B-40
B-14	Matrix Operations Order	B-41
Section IV.	OFFENSE OPERATIONS ORDERS	B-44
B-15	Warning Order	B-44
B-16	Five-Paragraph Field Order	B-45
B-17	Fragmentary Order	B-54
B-18	Matrix Operations Order	B-68

Section I. TYPES AND CHARACTERISTICS OF COMBAT ORDERS

There are five types of combat orders: operation, administrative/logistics, standing operating procedures, warning, and fragmentary.

B-1. TYPES OF COMBAT ORDERS

- a. Operation orders are directives issued to subordinate commanders to coordinate an operation. They dictate the conduct of tactical operations and the conduct of movements. They may be issued initially in the form of operation plans (OPLANs), to be implemented upon receipt of the appropriate directives. Standard, five-paragraph OPORDs have a prescribed format discussed in detail in FM 101-5.
- b. Administrative/logistics orders provide for the coordinated combat service support for a command. They are normally prepared and used at division level or higher.
- c. SOPs are a set of instructions that prescribe routine and fixed procedures. They supplement combat orders and have the same authority. SOPs reduce the volume and content of other combat orders by eliminating the need for detailed guidance. There is no prescribed SOP format.
- d. Warning orders are used extensively in battalion task force operations. They provide early notice of actions or orders that are to follow, to give subordinates maximum time for preparation for combat. Warning orders have no prescribed format. The warning order, written or oral, may include the following elements:
 - (1) **Heading.** Warning orders must always begin with the words "Warning Order" for easy recognition. The addressees are also included in the heading.
 - (2) **Situation.** This section includes a brief description of the enemy situation, events, probable missions, tasks, or operation.
 - (3) **Attachments/detachments.** These include any known changes to task organization.
 - (4) **Earliest time of move.** This states the earliest possible time that units must be ready to move. The actual time of move is given if it is known.
 - (5) **Nature and time of the operation.** This is stated in sufficient detail to allow recipients to begin preparation and set priorities. It also includes orders for preliminary actions

and reconnaissance. Time of the operation is stated as precisely as possible, to allow recipients to allocate time and complete their preparations.

- (6) **Time and place of orders group.** Subordinates are told when and where to go to receive the entire order. An SOP orders group — detailing who usually comes to receive orders — helps to shorten this process.
 - (7) **Administrative/logistical information.** This includes instructions that change support requirements, require special equipment, or direct movement to assembly areas.
 - (8) **Acknowledgment.** An acknowledgment of receipt of the order is always required to make sure it is received by all addressees.
- e. Frequently, operation orders are modified through the use of fragmentary orders during an operation to take advantage of tactical opportunities. A FRAGO has no specified format, but an abbreviated operation order format is usually used.
- (1) A FRAGO usually contains the following elements:
 - (a) Changes to task organization — any changes to the unit task organization made necessary by the modification to the order.
 - (b) Situation — a brief statement of the enemy and friendly situations, which usually gives the reason for the FRAGO and the higher commander's intent.
 - (c) Concept — orders to subordinate units on actions they are required to take, which are changed from the order with updated operations overlay and execution matrix, as necessary.
 - (d) Fire support — changes or additions to fire support.
 - (e) Coordinating instructions — changes to paragraphs 4 and 5 of the operation order made necessary by the change.
 - (2) If time and situation permit, the FRAGO should be issued by the commander face-to-face with his subordinates. This helps to ensure understanding of the new instructions and the commander's intent, and it allows the commander to provide graphics. When a FRAGO must be given over the radio, the FRAGO must be brief yet contain sufficient information to be clear. Code words and brevity codes are used if possible. Only those parts of the original order that have changed are mentioned. FRAGO procedures should be covered in SOPs.

- (3) Occasionally, the task force will receive a new mission not directly linked to the operation order that is in effect. If time is critical, the mission may be given to the task force in the form of a FRAGO. A mission statement would then be a necessary part of the FRAGO.

B-2. ESSENTIAL CHARACTERISTICS

- a. **Clarity.** Use accepted military terminology.
- b. **Brevity.**
- c. **Simplicity.**
- d. **Completeness.**
- e. **Authoritative Expression.** Orders reflect the commander's intention and will. Indecisive, vague, and ambiguous language leads to uncertainty. Subordinates are told in direct and unmistakable terms exactly what the commander wants them to do; they are not normally told **how** to accomplish it.
- f. **Timeliness.** Warning orders are issued and the one-third — two-thirds rule is observed.

Section II. FIVE-PARAGRAPH FIELD ORDER FORMAT

This section implements STANAG 2014 (Edition 5) and QSTAG 506.
--

Abbreviations and acronyms are used in orders to save time and space, but only if there is no loss of clarity. The use of abbreviations should be consistent throughout any plan or order.

B-3. DESIGNATION OF TASK FORCES AND TEAMS

- a. **Task Force.** There are two definitions of a task force; one is based on the mission and the other on organization. The one referred to in this manual is a battalion-size unit of armor or infantry to which one or more company-size units of the other combat arm has been attached or is under OPCON.
- b. **Team.** At the company level, a temporary grouping of units is called a team. The same rules apply for its formation as for the formation of a task force, except that platoons are the basic building blocks rather than companies.

c. Designations.

- (1) Task forces and teams may be designated as follows:
 - Name of the commander — Task Force Anderson.
 - Use of code name — Team COBRA.
 - Use of numeral — Team 1.
 - Use of letter — Task Force ALPHA (Team BRAVO).
 - Use of unit designation — TF 2-11.
 - Use of branch — Team Mech (TF Tank).
- (2) Attached or supporting companies may be renamed to avoid confusion. For example, if the task force has retained its Company A, and another Company A is attached, the attached company could be renamed Company Mech (Tank).

B-4. DIRECTION

Compass points are used in place of the terms left and right. If the situation indicates the advisability of including the terms left and right, they are placed in parentheses immediately following the appropriate compass point. Specific directions are given as angles from true, magnetic, or grid north (the type used is always specified).

B-5. DATE-TIME GROUP

A date-time group (DTG) is a six-digit number expressing date and time. The first two digits indicate the date of the month and the last four digits indicate the time. The month and year are added to avoid confusion. A complete date-time group would appear as follows: 241000Z January 1988.

B-6. TIME ZONE

The time zone used is the time zone that applies to the operation. Times in other zones are converted to this time zone for the operation. This entry is required in OPORDs and OPLANs and is shown as the entry following "Reference."

B-7. FORMAT

Standard OPORDs have a heading, a body, and an ending. (See Figure B-1.)

a. Heading.

- (1) **Classification.** The security classification is shown centered at the top and the bottom of each page of the order.
- (2) **No change from oral orders.** If no oral orders were issued, this comment is left out. If there were oral orders, such statements as "No change from oral orders" or "No change from oral orders except for paragraph ___" are used as appropriate.
- (3) **Copy number.** Assigned by S3 for accountability.
- (4) **Issuing unit.** Unit issuing the order or plan.
- (5) **Place of issue.** Name of easily recognized geographical feature nearest to the issuing headquarters' command post. Show coordinates of command post in parentheses, and state or country.
- (6) **Date-time group.** The time the order or plan is signed and effective, unless otherwise stated in the body of the order.
- (7) **Message reference number.** Assigned by the S3 for acknowledging and referring to the order in the clear.
- (8) **Operation order number.** Assigned by the S3. Numbers run serially throughout the year.
- (9) **References.** List any maps, charts, or other documents required to understand the order. Reference to a map includes the map series number (a country or geographical area), sheet number (and name if required), edition, and scale.
- (10) **Time zone used throughout the order.** The time zone applicable to the operation. Times in other zones are converted to this time zone for this operation.
- (11) **Task organization.**
 - (a) Major subordinate maneuver units of the task force issuing the plan or order are listed before other command and control headquarters in numerical or alphabetical order (by decreasing size), depending on the unit designation. When established, teams that are a major subordinate command are listed first in numerical or alphabetical order as appropriate. The task organization of each command and control headquarters of the force is shown by indenting subordinate units under the command and control headquarters heading. The indentation indicates that the

unit is organic, assigned, or attached unless qualified by a parenthetical term, such as (OPCON), or a support relationship, such as (DS) or (GS). The sequence for listing units is combat, combat support, and CSS. Combat units are listed by size in the order of infantry, mechanized infantry, air assault, airborne, and armored (armored units are listed in order of tank, attack helicopter, armored cavalry, and air cavalry units). Similar size and type units are listed in numerical or alphabetical sequence. Attached or supporting field artillery (FA) units are listed after maneuver units and are followed by other combat support units listed by size. CSS units are listed alphabetically by size after combat support units. The task organization may be depicted by phase of the operation, if appropriate. Names and ranks of commanders of each command and control headquarters may be indicated opposite the unit designation, if appropriate.

- (b) In addition to the listing of major subordinate units, a control grouping is also shown in the task organization, as appropriate, such as "BN Con" or "TF Con." Combat support elements supporting the task force are listed and indented under this heading. Units in general support of the higher headquarters, and artillery units that are reinforcing or general support-reinforcing to the task force's DS artillery, are not listed in the task organization. Such units are not under the direct control of the supported unit commander, and thus they are not listed under "TF Con." (Reinforcing or general support-reinforcing artillery is listed in paragraph 1b, Friendly Forces.)
- (c) At battalion level, combat service support elements are listed under a separate heading of "BN Trains" or "TF Trains." Any external CSS elements supporting the headquarters are listed indented under this heading. At company level, a trains listing is optional, based on the commander's discretion.
- (d) The use of the minus symbol (-) following the unit's heading indicates that a subelement has been detached.
- (e) When a command relationship has been established between an element and a headquarters, the supported commander cannot impose a more restrictive command relationship when suballocating that element to one of his subordinate units. For example, a unit placed

under OPCON of a task force cannot be attached to a company team either in whole or in part, since attachment is more restrictive than OPCON.

b. **Body.** (Subparagraph numbering matches OPORD numbering.)

1. **Situation.** This paragraph provides an overview of the general situation and always contains three subparagraphs in an OPORD: enemy forces, friendly forces, and attachments and detachments. An OPLAN adds a fourth: assumptions.

a. **Enemy Forces.** This subparagraph contains enemy information only, which is provided by the unit intelligence officer.

b. **Friendly Forces.** This subparagraph contains the verbatim mission statements of higher, adjacent, and supporting or reinforcing units, and the brigade commander's intent for the operation. It includes (in order):

(1) The mission and intent of the next higher headquarters (in a task force OPORD, the brigade mission and a short statement of the brigade commander's intent taken from the brigade's concept of operation subparagraph).

(2) The mission of adjacent units listed in sequence — left, right, front, and rear.

(3) The mission of units that are supporting or reinforcing the next higher headquarters.

c. **Attachments and Detachments.** When not shown in the task organization, units attached to or detached from the issuing headquarters are listed here. Additionally, if a unit is to be attached or detached after the effective time of the OPORD, it is listed here with the effective time and conditions under which the change in status will occur.

d. **Assumptions.** This is included in the preparation of an OPLAN. This subparagraph includes situations and conditions that a commander believes will exist at the time the OPLAN becomes an OPORD.

2. **Mission.** The mission is a clear, concise statement of the task(s) to be accomplished by the issuing unit and its purpose. The mission statement is derived from the commander's mission analysis during the decision-making process, and it addresses the WHO, WHAT, WHEN, WHERE, and WHY of

the operation. At battalion level and below, all of the essential tasks (critical to the success of the operation as determined by the commander) to be accomplished are addressed in the mission statement. The mission is always stated in full, and must stand alone without reference to any other documents except a map. For example:

"TF 2-77 conducts a passage of lines and attacks 130530A Sep 84 to seize HILL 295 (NB251369) and HILL 301 (NB296384); continues the attack to the east on order."

"TF 2-77 establishes defense from NA524165 to NA536109 NLT 210630A Nov 84; assists passage of the division covering force; and defends in sector to prevent penetration of the MUHLEN River."

3. **Execution.** The execution paragraph contains commander's concept and "how to" information needed for mission accomplishment. This paragraph consists of three elements: concept of operation, subordinate unit subparagraphs, and coordinating instructions.
 - a. **Concept of Operation.** Normally, the operation overlay is referenced in this part of the concept. The initial paragraph expands on the why of the mission statement to explain the "big picture" or master plan. It is the commander's concise personal summary of intent, which can be easily grasped and provides the basis for initiative. The commander's visualization of the enemy defeat and the outcome of the battle is expressed here without attempting to express every contingency.
 - (1) **Maneuver.** The scheme of maneuver describes the movement or placement of all major subordinate maneuver elements within the task force. The scheme of maneuver discusses the battle from start to finish, and describes HOW the operation will progress. It is stated in sufficient detail to ensure a thorough understanding of appropriate actions by subordinates.
 - (2) **Fires.** The scheme of fire support outlines the commander's concept for fires and integrates tasks for fires with the scheme of maneuver.
 - (3) **Obstacle, mines, and fortifications.** These items may be included in the concept of operation. Additionally, priorities of engineer effort and types of operations (mobility, countermobility, and survivability) may also be addressed. Detailed

information relating to an obstacle plan is included in a separate annex and referred to here.

- (4) **Intelligence and electronic warfare.** The concept may include a brief discussion of the commander's intelligence collection priorities and electronic warfare priorities and how they directly affect the scheme of maneuver.
- (5) **Other support activities.** Other aspects included in the concept are suppression of enemy air defense (SEAD), air defense fires, and rear area combat operations.

b. **Subordinate Unit Subparagraphs.** The specific tasks to be accomplished by each subordinate element of the task force are listed in a lettered subparagraph. The units are normally listed alphabetically or numerically in order of decreasing size by type of unit. Subordinate teams (combined arms elements) normally precede branch pure elements in sequence. Additionally, maneuver units precede combat support and combat service support units. At battalion level and below, all major subordinate units or units under task force control are listed in separate subparagraphs, with two exceptions: trains elements are addressed in paragraph 4, and a unit in reserve is addressed in the reserve subparagraph. Instructions in the concept of operation may be repeated in the subordinate unit subparagraphs if the commander feels it is necessary for clarity; however, it is not mandatory to repeat. Instructions in the subordinate unit subparagraphs are limited to tasks that apply to a particular unit and only that unit. In addition to the listing of units, the following items may appear in the subordinate unit subparagraph portion of the OPORD.

- **Fire Support.** (Not mandatory.) This subparagraph may contain a discussion of air support, chemical operations, field artillery (organization and special instructions), naval gunfire, and nuclear fires. This subparagraph is not the same as the plan of fire support discussed under the concept of operation, and it does not substitute for a discussion of fire support in the concept.
- **Air Defense, Aviation, Engineer, and Military Intelligence.** These subparagraphs are sometimes used. (Not mandatory.)

- **Reserve.** A reserve subparagraph is included in the format of the order for company level and higher. It is listed in sequence as the last subordinate unit subparagraph immediately preceding coordinating instructions. If no reserve is planned, the word NONE is shown. A unit totally in reserve during the operation appears **only** in this subparagraph (in addition to the concept of operation).
 - **Coordinating Instructions.** This last subparagraph contains details of coordination and control applicable to **two or more elements of the task force**, with the exception of signal items, which are covered in paragraph 5b. Typical items included in coordinating instructions are:
 - Reports other than SOP that are to be made.
 - NBC troop safety instructions and operational exposure guidance (OEG).
 - MOPP levels, if different from SOP.
 - Air defense criteria.
 - Consolidation and reorganization instructions, if other than SOP.
 - Priority intelligence requirements (PIR), if not stated in an intelligence annex.
 - Passage of lines coordination.
 - Effective DTG, or conditions under which the order or plan becomes effective when not effective upon receipt.
 - Reference to annexes included in the order (plan) not previously mentioned in the body of the order.
4. **Service Support.** This paragraph contains combat service support instructions and information relating to the operation. General information such as the MSR, LRPs, time and composition of LOGPACs, and methods of resupply and evacuation for supporting units is contained here. There is no doctrinal format for paragraph 4; however, the administrative/logistics order format is recommended as follows (reference may be made to unit SOP if appropriate; items not required are omitted).
- a. **Materiel and services.** Status of classes of supply, transportation, services, and maintenance.

- b. **Medical evacuation, aid station locations, and hospitalization.**
 - c. **Personnel.** Unit strengths, replacements, maintenance of morale, discipline, law and order, headquarters management.
 - d. **Civil-military cooperation.** Limitations or restrictions concerning local area; psychological operations.
 - e. **Prisoner of war procedures.**
 - f. **CSS facilities.** The locations and proposed locations of CSS facilities (combat or field trains) may be indicated; however, this is not necessary if shown on an overlay.
5. **Command and Signal.** This paragraph contains instructions and information relating to command and communications-electronics functions. It has two subparagraphs— command and signal.
- a. **Command.** As a minimum, this subparagraph includes the initial location of the commander (to facilitate messenger operations if they become necessary); it may also include the command post locations (required if not shown graphically) and CP axis of displacement. Succession of command may be shown, if different from SOP.
 - b. **Signal.** As a minimum, this subparagraph lists the SOI index by specific number in effect for the operation as well as any changes scheduled during the operation, it may also list alternate or emergency signals (for example, pyrotechnics) and any signal restrictions, such as radio-listening silence.
- c. **Ending.**
- (1) **Acknowledge.** Directs the recipient of the order to acknowledge receipt. Acknowledgment may be made **in the clear** using the message reference number in the OPORD heading. Any instructions pertaining to acknowledging the receipt of the order (plan) may be listed here.
 - (2) **Signature.** The commander or his authorized representative signs the original copy of the OPORD.
 - (3) **Authentication.** If the commander's signature cannot be reproduced, the S3 authenticates subsequent copies of the order. Annexes issued with the order do not require signature or authentication. Annexes issued separately require or authentication in the same manner as the order. Authentication is performed by the primary staff officer responsible for the annex.

- (4) **Annexes.** Lettered alphabetically and listed in the order in which they appear in the OPORD. S3 designates the letter to be associated with a given annex. Annexes are prepared by the appropriate officer having staff responsibility for the activity, arm, or service covered by the annex. When an annex is to be issued later and, therefore, does not accompany the order, the parenthetical phrase "(to be issued)" is shown following the listing of the annex.
- (5) **Distribution.** Establish distribution in coordination with appropriate staff officers. Distribution must also be made to adjacent, supporting, and attached units not included in the SOP distribution.

NOTE: Because of the dynamic nature of the battlefield, the task force OPORD may be written initially in one copy and given orally.

(Classification)

(No change from oral orders)

Copy No. ___ of ___ copies
Issuing unit
PLACE OF ISSUE
Date-time group
Message reference number

OPORD or OPLAN number

Reference:

Time Zone Used Throughout the Order:

Task Organization:

1. SITUATION
 - a. Enemy Forces.
 - b. Friendly Forces.
 - c. Attachments and Detachments.
 - d. Assumptions. (Only in operation plans.)
2. MISSION
3. EXECUTION
 - a. Concept of Operation.
 - (1) Maneuver.
 - (2) Fires.

(Classification)

Figure B-1. Operation order format.

<p><u>(Classification)</u></p> <p>(3) Obstacles, Mines, and Fortifications.</p> <p>(4) IEW.</p> <p>(Specific tasks for subordinate attached or supporting units. Include one subparagraph for each attached, supporting, or OPCON element such as Stinger teams, AVLB.)</p> <p>b. Tm A:</p> <p>c. Tm Tank:</p> <p>d. Co C:</p> <p>e. Co D:</p> <p>f. Scout Platoon:</p> <p>g. Mortar Platoon:</p> <p>h. ADA:</p> <p>i. Engr:</p> <p>j. GSR:</p> <p>k. The reserve, if designated, is always listed just before coordinating instructions.</p> <p>l. Coordinating Instructions:</p> <p>4. SERVICE SUPPORT</p> <p>a. General.</p> <p>b. Materiel and Services.</p> <p>c. Medical Evacuation and Hospitalization.</p> <p style="text-align: center;"><u>(Classification)</u></p>

Figure B-1. Operation order format (continued).

(Classification)

- d. Personnel.
- e. Civil-Military Cooperation.
- f. Miscellaneous.

5. COMMAND AND SIGNAL

- a. Command.
- b. Signal.

Acknowledge:

(Commander)

Authentication:
Annexes:
Distribution:

(Classification)

Figure B-1. Operation order format (continued).

B-8. OVERLAYS

- a. The overlay is a graphic representation of the commander's scheme of maneuver and intent. Its purpose is to ensure coordinated action between all units. **THE OVERLAY IS PREPARED ON THE SAME SCALE MAP THE SUBORDINATE COMMANDERS ARE USING.** Overlay techniques involve the use of military symbology and control measures from FM 101-5-1 to graphically portray in a condensed form plans, orders, and information concerning the military situation. Only the minimal necessary control measures are used so as not to clutter or confuse the overlay.
- b. When the overlay and the written portion of the plan or order are separate documents —
 - (1) The overlay is an annex; when it is issued as an integral part of the order and has the same distribution as the order, it need only be identified by title and headquarters; for example, Annex A (Operation Overlay) to OPORD 2, TF 2-11.
 - (2) A reference to the overlay annex is in the written portion of the order.
- c. When the overlay and any written portion of the order are on the same piece of paper —
 - (1) A single heading and ending serve both the overlay and the written portion.
 - (2) No written reference to the overlay is required.
- d. When representations by colors are practicable, the following colors are used on overlays —
 - (1) Green — friendly or enemy man-made obstacles.
 - (2) Red — enemy units.
 - (3) Yellow — friendly or enemy areas of NBC contamination.
 - (4) Blue or black — friendly units.
 - (5) If only one color is available, friendly symbols are outlined with single lines, enemy symbols with double lines.
- e. The grid intersections nearest the two opposite corners of the overlay should be traced on the overlay and labeled with the proper grid coordinates. A four-digit grid is sufficient. These register (witness) marks show exactly where the overlay fits on the map.

B-9. TASK FORCE EXECUTION MATRIX

An execution matrix lists the task force's major subordinate units and the missions or tasks assigned to them during each stage of an operation. While not required, an operation overlay that includes an execution matrix provides the task force leaders with a readily accessible, sequential summary of all taskings.

B-10. CONSTRUCTION OF AN EXECUTION MATRIX

A typical execution matrix shown on many operations overlays is shown in Figure B-2. There is no specified format for the matrix. The techniques listed below may be used to construct one.

- a. First, establish the basic matrix. All major subordinate elements, including scouts, mortars, and any attached, OPCON, or DS combat support units, should be listed across the top of the matrix.
- b. Second, list the stages or phases for the operation down the left column. If desired, skip a row after each stage to provide space for on-order and be-prepared missions.
- c. Finally, fill in the blocks with brief descriptions of the actions required for each stage or phase of the operation; use abbreviations whenever possible. If the tasking for a unit is the same in successive stages, list it only the first time; do not recopy it. If additional instructions are required, such as orientation of fires, directed movement techniques, position in a formation, or obstacle responsibility, draw a diagonal line through the box and list the action required in the upper left-hand portion and the additional instructions in the lower right-hand portion of the divided block. (Sample completed execution matrixes are shown on the Operation Overlays for Figures B-4 and B-7.)

	TMA	TMB	COC	COD	COE	SCTS	MORT	FA	ENG	ADA
MOVE										
AA										
TO										
LD										
SEIZE										
OBJ										
CAT										

Figure B-2. Execution matrix.

Section III. DEFENSE OPERATIONS ORDERS**B-11. WARNING ORDER**

- a. Figures B-3 through B-5 show the progression of a defensive order from a warning order to OPORD and a modifying FRAGO. These orders are examples of the detailed orders that would be prepared if time and facilities are available. Figure B-6 shows a FRAGO that is issued over a secure radio net. Figure B-7 is an example of a task force hasty attack.

(Classification)

WARNING ORDER

TO: Orders Group ALPHA

FROM: Cdr, 1-33 Mech

SITUATION: Elements of the 4th MRD are in assembly areas vic VOLKERSHAUSEN (GL7428); they are part of the 8th CAA first echelon divisions arrayed for attack against the 23d AD. It is estimated that these divisions will not cross the IGB for 48 hours (311200A OCT 85).

ATTACHMENTS/DETACHMENTS: Co D/1-33 Mech attached to 1-48 Armor, effective 290600A OCT 85. Co D 1-48 Armor, attached to 1-33 Mech, effective 290600A OCT 85. Further cross attachment within TF 1-33 AR is as follows: 1/D/1-48 Armor attached to A/1-33, 1/A/1-33 Mech attached to D/1-48 Armor, one Tm Stinger each to A&B/1-33 Mech and D/1-48 Armor.

EARLIEST TIME OF MOVE: Earliest time of main body movement to defensive positions is 290630A OCT 85. Order of movement will be designated at OPORD.

NATURE AND TIME OF THE OPERATION: TF 1-33 Mech defends in sector NLT 311200A OCT 85 from FL988652 TO FL984604 and FL880610 to FL887657, to destroy one MRR.

TIME/PLACE OPORD ISSUANCE: TF 1-33 OPORD will be issued vic FL894632 at 291200A OCT 85. Orders group ALPHA will attend.

ADMINISTRATIVE/LOGISTICAL INFORMATION: TF XO will ensure BMO and support platoon leader coordinate with TF 1-48 for receipt/transfer of logistical/maintenance slice to support the operation. All companies ensure all units have basic load Class V.

Acknowledge.

(Classification)

Figure B-3. Example warning order (defense).

B-12. FIVE-PARAGRAPH FIELD ORDER

<u>(Classification)</u>	
(No change from oral orders.)	
Copy 4 of 25 copies TF 1-33 Mech, 2d Bde, 23d AD JOSSA (FL894632), FRG 291200A OCT 85 WFC 16	
OPORD 7-85	
Reference: Map, Special Series, FRG 1:50,000.	
Time Zone Used Throughout Order: ALPHA	
Task Organization:	
Tm A A/1-33 Mech (-) 1/D/1-48 Armor Tm D D/1-48 Armor (-) 1/A/1-33 Mech 1/B/1-33 Mech Co B B/1-33 Mech (-)	Co C C/1-33 Mech Co E E/1-33 Mech TF Con Scout/1-33 Hvy Mortar/1-33 B/23d Engr (DS) 1/A/23d ADA (V) (DS) A/4/A/23d ADA (S) 1&2/2/B/23d MI
1. SITUATION	
a. Enemy Forces. Annex A (Intelligence).	
b. Friendly Forces.	
(1) 2d Bde, 23d AD defends in sector 311200A OCT 85 from FL983708 to FL984604 and FL824613 to FL830712;	
<u>(Classification)</u>	

Figure B-4. Example five-paragraph field order (defense).

(Classification)

Cdr, 2d Bde intends to defeat lead MRRs forward of PL GREEN and convince enemy to commit the 2d echelon MRR in TF 1-33 sector.

(2) TF 1-48 defends in sector to the north (left) 311200A OCT 85 from FL983708 to FL988652 and FL887657 to FL890709 to destroy one MRR at the FEBA.

(3) 3d Bde defends in sector to the south (right) 311200A OCT 85 from FL984604 to FL980502 and FL819508 to FL824613.

(4) 1/208 ACR delays in sector to the east (front) from IGB to PL RED.

(5) TF 2-48 is 2d Bde reserve to the west (rear) vic AA JOYCE (FL8469). On order conducts counterattack through TF 1-48 forward of FEBA.

(6) 1-51 FA (155 SP) DS to 2d Bde. 2-363 FA (155,SP) GS; 0/0 GSR 1-51 FA.

(7) B/23 AVN OPCON to 2d Bde.

(8) B/23d ADA (-) DS to 2d Bde.

(9) B/510 Engr (Corps) DS to 2d Bde.

(10) 2/23d MP DS to 2d Bde.

c. Attachments and Detachments: Task Organization.

2. MISSION

TF 1-33 defends in sector 311200A OCT 85 from FL988652 to FL984604 and FL880610 to FL887657 to destroy one MRR.

(Classification)

Figure B-4. Example five-paragraph field order (defense) (continued).

(Classification)

3. EXECUTION

a. Concept of Operation. Annex B (Operations Overlay). The intent is to accept the battle from 1/208 at PL RED, to pass 1/208 through the FEBA, and to destroy 3 tank companies forward and in the vicinity of BP 1-1. The obstacle system and fires will assist the task force in shaping the penetration into EA GOLF. When the lead infantry companies begin deploying to assault the strongpoint (SP 3-1), the task force counterattacks with Tm D along AXIS DELTA.

(1) Maneuver. TF 1-33 defends in sector, initially with Co B forward, Tm A in BP 1-1, Tm D Reserve in BP 4-1, Co C in SP 3-1, and Co E in GS. Co B establishes contact with 1/208 ACR at CP 4, accepts battle handover along PL RED, assists passage of lines of the covering force along ROUTE NORTH and delays in sector to destroy enemy reconnaissance elements and force the lead MRBs to deploy. On order, Co B withdraws to BP 2-1 overwatched by Tm A and Co E. Tm A defends BP 1-1 and moves to BP 1-2 to draw the enemy into EA GOLF. Co C in SP 3-1 will block the enemy attack as Tm A and Co B destroy the lead MRBs with direct flanking fires from BP 1-2 and BP 2-1 respectively. Co E provides AT fires into EA GOLF from west of PL BLUE. On order, Tm D counterattacks by maneuver to BP 1-1 to destroy the 2d echelon MRB. On order, TF 1-33 supports by fire TF 2-48 counterattack east of BP 1-1.

(2) Fires. Priority of FA fires to Co B, then to Tm A after withdrawal of Co B to BP 2-1. Priority of mortar fires to Tm A, then to Co B after occupation of BP 2-1. Priority of fires to Tm D when committed to CATK. Mortar platoon FPF allocated to Co C. (See Annex C.)

(3) Obstacles, Mines, and Fortifications. Priority of effort to survivability for construction of SP then to countermobility. Countermobility priority to obstacles

(Classification)

Figure B-4. Example five-paragraph field order (defense) (continued).

(Classification)

supporting EA GOLF and BP 1-1, then to Co B sector. Priority of effort shifts to mobility to support CATK. (See Annex D.)

b. Tm A.

(1) Defend 311200A OCT 85, BP 1-1 (FL948638) orienting between TRPs 403-406 to destroy the tank companies of the lead MRBs.

(2) Prepare and occupy on order. BP 1-2 (FL953628) orienting between TRPs 401-401 to destroy one MRB.

(3) Recon and occupy on order BP 1-3 (FL894668).

(4) Support by fire Tm D's counterattack.

c. Tm D.

(1) Defend 311200A OCT 85, BP 4-1 (FL924589) orienting between TRPs 401-405 to retain the NEIDERSTADT hill mass.

(2) On order, counterattack by maneuver along AXIS DELTA to BP 1-1 to destroy enemy 2d echelon MRB.

(3) Rehearse counterattack and recon BP 1-1.

(4) Recon and occupy on order BP 4-2 (FL873576).

d. Co B.

(1) Delay in sector 311200A OCT 85, from FL988652 to FL984604 and FL965602 to FL967656 to force enemy lead MRBs to deploy.

(2) Prepare and occupy on order, BP 2-1

(Classification)

Figure B-4. Example five-paragraph field order (defense) (continued).

(Classification)

(FL953649) orienting between TRP 402-404 to destroy one MRB.

(3) Recon and occupy on order BP 2-2 (FL904647).

(4) Establish contact at CP 4 and assist passage of covering force along ROUTE NORTH.

(5) Accept battle handover along PL RED.

(6) Coordinate and rehearse with Tm A rearward move from sector to BP 2-1.

(7) Support by fire Tm D's counterattack.

e. Co C: Defend 311200A OCT 85, SP 3-1 (FL935640) orienting fire between TRPs 402-404 to retain the chokepoint at OBERDORF.

f. Co E.

(1) GS; Overwatch Co B and Tm A move to BP 2-1 and 1-2, respectively.

(2) Provide AT fires into EA GOLF between TRPs 401-402 from west of PL BLUE.

(3) On order, provide overwatch to Tm D counterattack from BPs 1-2 and 4-1.

g. Scouts.

(1) Screen 311200A OCT 85, TF south flank from FL964602 to FL940564.

(2) Upon Tm A occupation of BP 1-2, screen from FL940564 to FL880610.

(Classification)

Figure B-4. Example five-paragraph field order (defense) (continued).

(Classification)

(3) Establish contact with 3d Bde at CP 3.

(4) Coordinate with GSR for attachment during screen west of CP 3.

h. Mortars.

(1) Priority of fires to Tm A with one section vic FL973634. Displace to FL904628 upon Co B occupation of BP 2-1. Priority then shifts to Co B.

(2) Provide FPF to Co C with one section vic FL901642 initially.

(3) Priority of fires shifts to Tm D to support counterattack.

i. B/23d Engr (DS).

(1) Engineer effort will be east of PL BLUE until Co B begins movement from sector to BP 2-1, then effort will be between PL GREEN and PL BLUE.

(2) Engineer efforts forward of the FEBA will stop when the covering force begins rearward passage of lines.

(3) Be prepared to occupy and defend BP 4-2 (FL924589).

j. 1/A/23d ADA (V) (DS).

(1) Priority of protection to combat trains and SP 3-1.

(2) Priority of protection shifts to Tm D for counterattack.

(Classification)

Figure B-4. Example five-paragraph field order (defense) (continued).

(Classification)

k. 2/B/23d MI (-).

(1) Priority of surveillance to enemy avenues of approach from the south (right).

(2) Attached to SCT PLT during screen west of CP 3.

l. Reserve.

(1) Tm D initially in BP 4-1.

(2) Tm A upon initiation of counterattack.

m. Coordinating Instructions.

(1) MOPP 1 in effect 310600A OCT 85.

(2) OEG: 50 cGy, negligible risk to unwarned exposed personnel.

(3) Bde decon site vic DUNKEL (FL756723). Bn hasty decon site vic LINKEN (FL883621).

(4) Direct fire target priority shifts to enemy ADA upon commitment of friendly CAS or attack helicopters.

(5) ADA: WCS - Tight; others WCS - Hold; ADW -P Yellow.

(6) Unit R&S plan IAW Annex A (Intelligence).

4. SERVICE SUPPORT Annex F (Service Support)

5. COMMAND AND SIGNAL

a. Command.

(1) Main CP initially at FL894632, displace to

(Classification)

Figure B-4. Example five-paragraph field order (defense) (continued).

(Classification)

FL897610 o/o.

(2) Commander initially in BP 1-1.

(3) 2d Bde TAC CP vic FL887724, MAIN CP vic FL834703.

b. Signal.

(1) SOI KTV-600B in effect, KTV-600C in reserve.

(2) Bn retrans vic FL972661 until covering force begins passage of lines then displace to vic FL872599.

(3) Radio-listening silence in effect except for Cdrs, Scouts, and enemy sighting spot reports. Silence lifted upon passage of covering force.

Acknowledge.

ROCK
LTC

OFFICIAL:

(SIGNED)
S3

Annexes: A - Intelligence
B - Operation Overlay
C - Fire Support
D - Engineer
E - Air Defense (Omitted)
F - Service Support
G - Signal (Omitted)
H - Contingencies (Omitted)

DISTRIBUTION: A

(Classification)

Figure B-4. Example five-paragraph field order (defense) (continued).

(Classification)

ANNEX A (Intelligence) to TF 1-33 OPORD 7-85

Reference: Basic OPORD.

1. GENERAL. (See Appendix 1.)

a. Enemy Situation.

(1) Location. Elements of the 4th MRD (GDR) are in assembly vic VOLKERSHAUSEN (GL7428). This division is one of the 8th CAA's first echelon divisions and is arrayed against the 2d Brigade, 23d AD. The 8th CAA's ITR (150 Tanks) is located vic MERKERSHAUSEN (GL8431) with the 2d echelon tank division located 50-80 km east of VOLKERSHAUSEN.

(2) Strength. Threat units are presently at 95% strength in equipment and personnel.

b. Enemy Capabilities. The enemy is not expected to cross the IGB for 48 hours. It is anticipated that upon initiation of hostilities, enemy will be in the brigade sector within 12-15 hours. The enemy can attack in the 2d Brigade sector with one MRD (-) possibly followed by the ITR and a second echelon TD. TF 1-33 can expect a reinforced MRR (BMP equipped) in the first echelon. The enemy can air-mobility a battalion-size force with gunship support to seize crossing sites across the FULDA RIVER into BREITENBACH or ALSFELD. The enemy can also establish local air superiority for limited periods. Early use of chemical agents is anticipated.

c. Most Probable Course of Action. The 168th MRR will attack in TF 1-33 sector along AA/A with two reinforced MRBs in the first echelon followed by one MRB in the second. The first echelon MRBs will attack along AA/A and A₂ to seize Bn immediate objectives vic FL9267 to FL8955. Expect the

(Classification)

Figure B-4. Example five-paragraph field order (defense) (continued).

(Classification)

2d echelon MRB to be committed at this point along AA/A₂ and to continue west switching to AA/A₁ vic FL8762 to seize the MRR immediate objective vic FL8666 to FL8656. Expect RAG to support initial attack vic FL0263. Significant flank AA from the south are Bn size: AA/C₁-FL9356, AA/C₂-FL9055, and AA/C₃-FL8754. From the north, one Bn and one Co-size AA are significant: AA/B₂-FL8968 and AA/B₁-FL9368, respectively.

2. PRIORITY INFORMATION REQUIREMENTS (PIR).

a. Has the 2d echelon MRB been committed to AA/A₂ (NAI 30, 31, 36, and 40)?

b. Where has the RAG been positioned (NAI 30)?

c. Is the enemy attempting to attack the TF flanks (NAI 20, 21, 22, 23, and 24)?

d. Will the enemy conduct airborne/airmobile insertions (NAI 34, 35, and 38)?

e. Is the enemy in MOPP 3 or 4?

3. INTELLIGENCE ACQUISITION TASKS.

a. Subordinate and Attached Units. Appendix 2 (R&S).

b. Higher and Adjacent. Appendix 1 (Enemy Situation).

4. MEASURES FOR HANDLING PERSONNEL DOCUMENTS AND MATERIAL. SOP.

5. DOCUMENTS AND EQUIPMENT REQUIRED.

(Classification)

Figure B-4. Example five-paragraph field order (defense) (continued).

(Classification)

a. Maps: Special Series, FRG, 1:50,000.

b. Subordinate Units R&S Plans - Submit NLT 300600S
OCT 85.

6. COUNTERINTELLIGENCE. Appendix 2 (R&S).

7. REPORTS AND DISTRIBUTION. SOP.

8. MISCELLANEOUS INSTRUCTIONS.

APPENDICES:

1 - Enemy Situation

2 - R&S

3 - Weather (Omitted)

(Classification)

Figure B-4. Example five-paragraph field order (defense) (continued).

(Classification)

APPENDIX I (Enemy) to ANNEX A (Intelligence) to TF 1-33
OPORD 7-85

NAI	RAS REQUESTS/Responsibilities			TF TAE	DECISION POINTS	
	HIGHER/ARE	TF	SUBUNITS		ACTIVITY	ACTION
20	2d Bde/200ACR		TM B	FA	MRE moving NW	TAI B TO BP 2-1
21	2d Bde/3d Bde	GSR	SCT	FA	MRE moving NW	TAI 27 - HOLD BPL: TMA to BP1-2
22	2d Bde/3d Bde	GSR	SCT	FA	MRE moving NW	TAI 28 OCCUPY BP4-2
23	2d Bde/TF1-40	GSR	TM-P	FA	MRE moving SW	OCCUPY BP2-2
24	2d Bde/TF1-40			FA	MRE moving S	TAI 40 NOTIFY TM B
30	2d Bde/1st ABN	GSR		FA		
31			TM-A	MORDES		TAI D CARE
32			TM-A	FA	MRE moving W	
33			TMA/TM-D		MRE moving N	TMD AND BP4-1
34			TM-D/TM-A	MORDES		
35			TMA			
36			TM B/TMA		MRE moving W	TAI 32
37			SCT/TMD	FA	MRE moving NW	TAI 34
38			SCT/TMD	FA		
39			TM B			
40			TMB/TMA	MORDES	MRE moving W	TAI 31

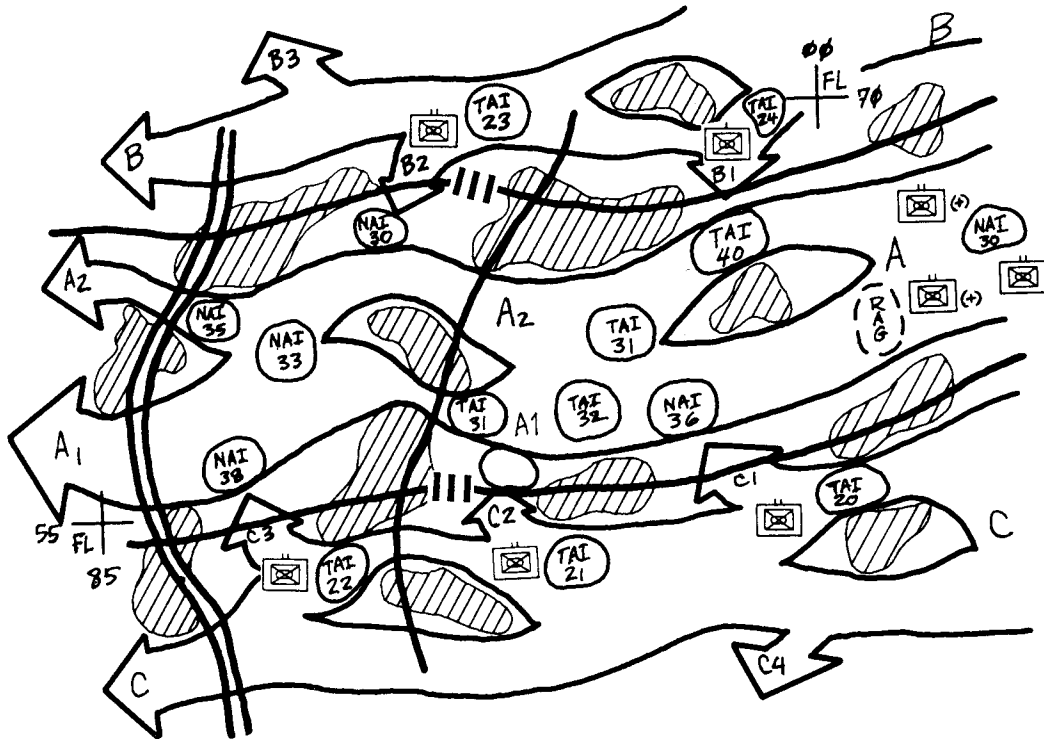

(Classification)

Figure B-4. Example five-paragraph field order (defense) (continued).

(Classification)

APPENDIX 2 (R&S) to ANNEX A (Intelligence) to TF 1-33 OPORD 7-85

OP	UNIT	POSITION	NAI TARGET	INSTRUCTIONS
10	A	1-1	36	
11	A	1-1	40	
20	B	SECTOR	40	
21	B	SECTOR	20	
22	B	2-1	23	
23	B	2-2	23/39	
30	C	3-1		
40	D	4-1	34/37	
41	D	4-2	33	
PATROL SPTS				
A	B	SECTOR		COORD W/CF AT CP4
B	A	1-1	31/40	PATROL 0200, 0600, 1400, 2100
C	A	1-1	32	COORD W/ SCTS, PATROL 0100, 2000, 2400
D	B	2-1	23/	PATROL 2000, 0600 CHECK MF & ATD
E	A	1-2		PATROL 0600, 1800 CHECK MF & ATD
F	D	4-1		COORD W/ GSR
G	B	2-2	39	COORD W/ GSR
H	A	1-3	33/35	COORD W/ TMDNT OP 41
I	D	4-2	38	COORD W/ SCTS

GSR		
POSITION	NAI TARGET	INSTRUCTIONS
1	21	INITIAL - COORD W/ D/1-40 & SCTS
2	22	COORD W/ D/1-40
3	30/40	INITIAL - COORD W/ B/1-33, DISPLACE TO POSITION 2 UPON WITHDRAWAL OF CO B TO BP 2-1.
4	23	OCCUPY ON ORDER
SCTS		
POSITION	NAI TARGET	
INITIAL SCREEN	21	
SUBSEQUENT SCREEN	22	

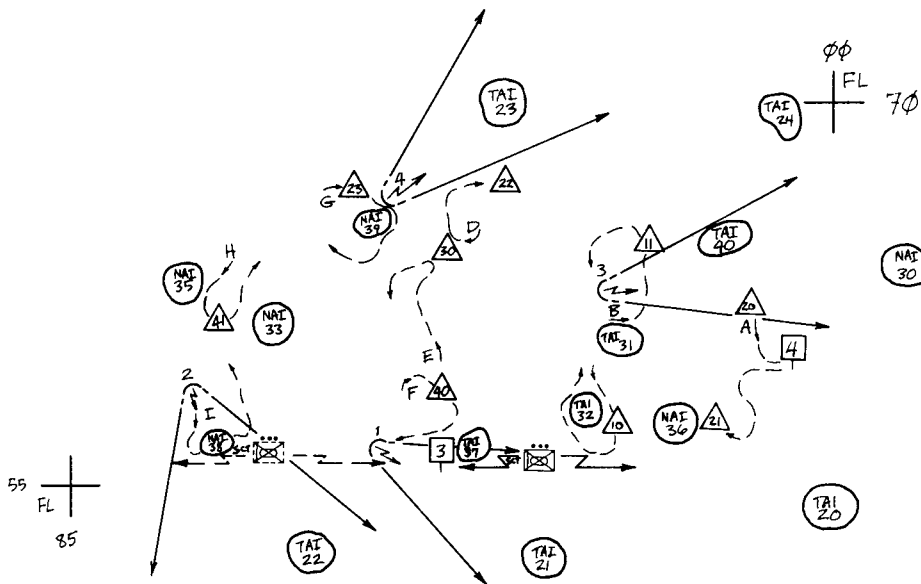

(Classification)

Figure B-4. Example five-paragraph field order (defense) (continued).

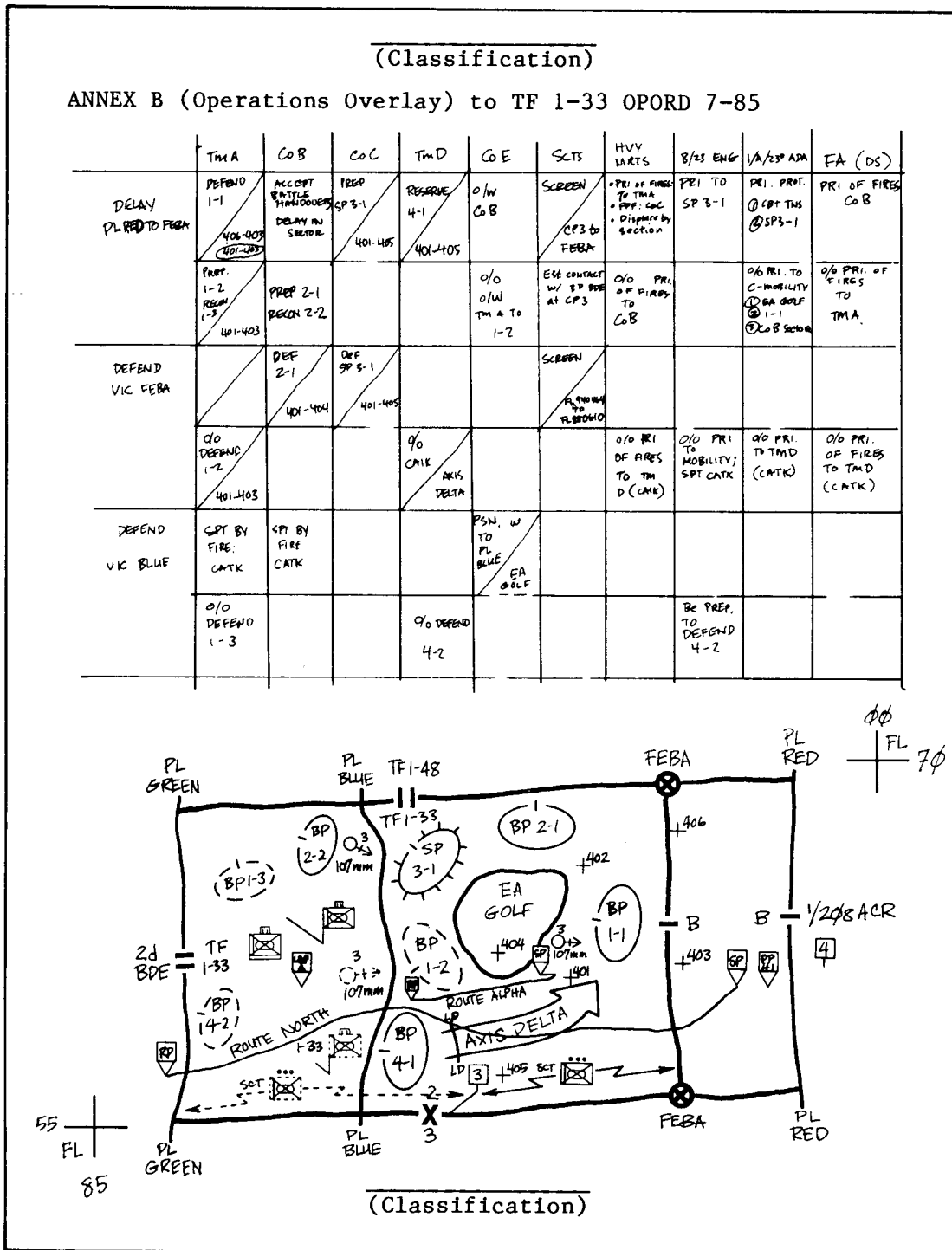

Figure B-4. Example five-paragraph field order (defense) (continued).

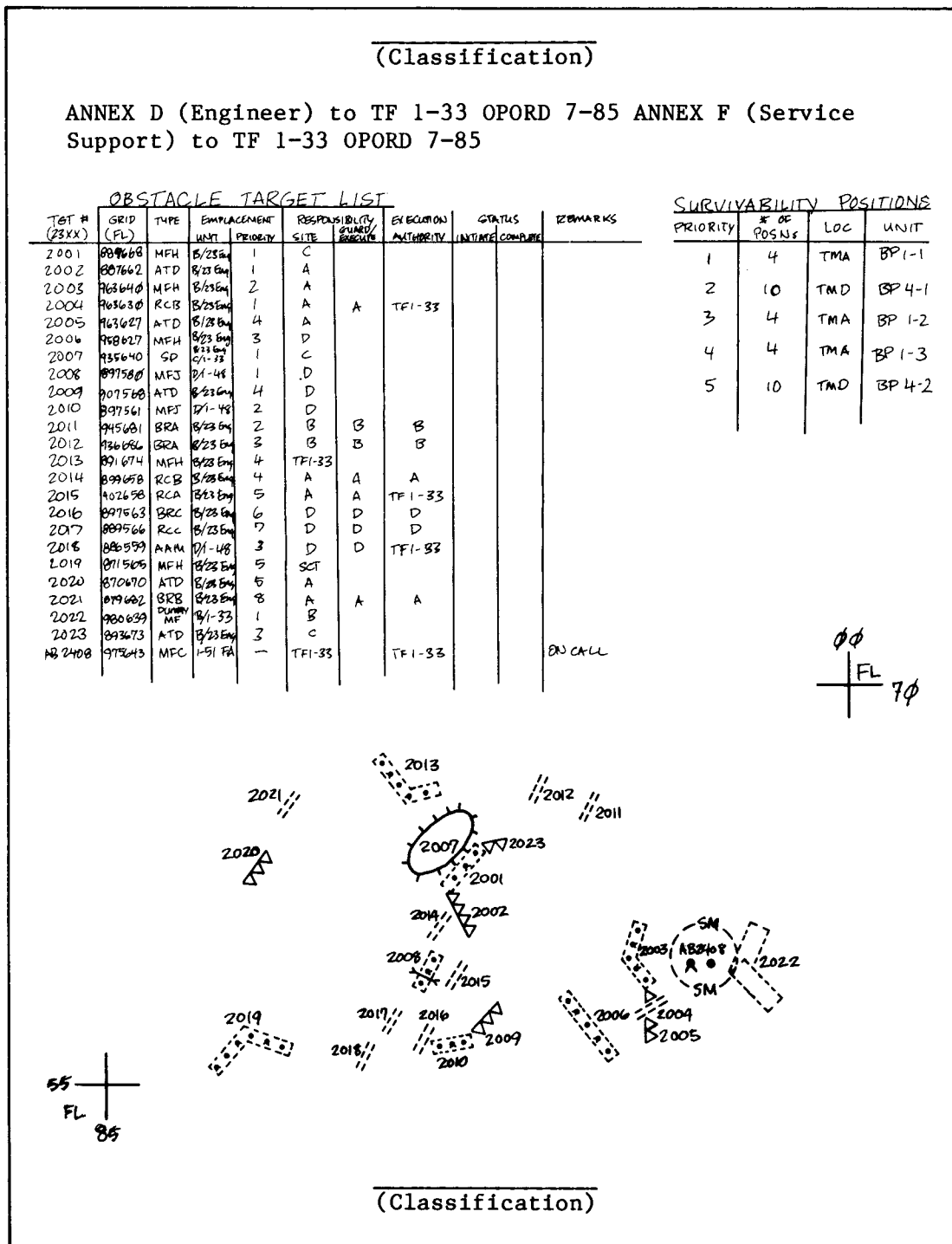

Figure B-4. Example five-paragraph field order (defense) (continued).

(Classification)

ANNEX F (Service Support) to TF 1-33 OPORD 7-85

Reference: Basic OPORD.

1. General.

- a. TF Fld trains located in BSA FL783712.
- b. TF Cbt trains, location vic FL881620.
- c. LOGPACS to LRP A, 1700-2100.

2. Material and Services.

a. Supply:

- (1) CL I: Maintain 3 days MCI.
- (2) CL III:
 - (a) Mobile (1 tanker) located Cbt trains.
 - (b) Tm D refuels on BP or from prepositioned tanker.
 - (c) Co B and Co C request as needed.
- (3) CL IV: 1000m triple standard concertina to each Co/Tm. Barrier material will be stockpiled vic FL934638.
- (4) CL V:
 - (a) Mobile (1 truck) located at Cbt trains.
 - (b) All Co/Tms rearm from caches on BPs.
 - (c) CSR: 107mm HE - 145 rds.

(Classification)

Figure B-4. Example five-paragraph field order (defense) (continued).

(Classification)

(d) Each team is allocated eight 40-pound cratering charges and 500 pounds of C-4.

(5) CL VII: Restricted issue on:

(a) Carrier, personnel (all).

(b) Tank, combat.

(c) Truck, cargo, 5-ton (all).

b. Transportation: TF supply route SP FL883642 to TCP 1 FL897633 to RP FL910636.

c. Services: Bde GRREG located at BDE trains. Evac with LOGPAC. Water point: FL884621.

d. Maintenance.

(1) UMCP - FL884640.

(2) TF M88Als located in UMCP.

(3) Bde maintenance effort is to TF 1-48 AR.

(4) Cannibalization authorized by BMO.

3. Medical. TF aid station located at combat trains. Bde clearing station FL788722. Aero evac per SOP.

4. Personnel. PW collection per SOP.

5. Civil-Military Cooperation.

a. Use of civilian labor assets or transportation must be approved by the Bn commander.

b. Civilian curfew 1700-0800 hours daily.

(Classification)

Figure B-4. Example five-paragraph field order (defense) (continued).

(Classification)

6. Miscellaneous.

- a. Water resupplied in LRP A.
- b. Maps requisitioned three days in advance from S2.

(Classification)

Figure B-4. Example five-paragraph field order (defense) (continued).

B-13. FRAGMENTARY ORDER

<p>(Classification)</p>
<p>Copy No. ___ of Copies TF 1-33 Mech, 2D Bde, 23AD JOSSA (FL897610), FRG 010245A Nov 85 WFC 17</p>
<p>FRAGO 1 to OPORD 7-85</p>
<p>1. SITUATION</p> <p>a. Enemy force confronting 208 ACR and TF 1-12 is confirmed as 4 MRDs. CF units have achieved higher attrition rates than estimated, and will withdraw earlier than planned. Enemy forces have air superiority for the next 4 to 6 hours.</p> <p>b. 1-208 ACR and TF 1-12 will conduct rearward passage of lines in TF 1-33 sector within 2 hours.</p>
<p>2. MISSION</p> <p>TF 1-33 assists rearward passage of lines of CF and 1-208 NLT 010445A Nov 83.</p>
<p>3. EXECUTION</p> <p>a. TF 1-33 maintain current positions. Co B mans CP 4 and PP 41 to accept passage of CF units, and accept battle handover. Co B remains forward until CF units are moving along Route North. Co B withdraws to BP 2-1 on order.</p> <p>b. Coordinating Instructions.</p> <p>(1) ADW: Red.</p> <p>(2) WCS: Weapons free, effective 301200A Oct 1985.</p>
<p>(Classification)</p>

Figure B-5. Example written FRAGO (defense).

<u>(Classification)</u>	
4. COMMAND AND SIGNAL	
TF commander currently at 897610.	
Acknowledge	
	SMITH LTC
OFFICIAL	
JONES S3	
DISTRIBUTION: C	
<u>(Classification)</u>	

Figure B-5. Example written FRAGO (defense) (continued).

B-14. MATRIX OPERATIONS ORDER

- a. Matrix operations orders may be used as an alternative to the standard five-paragraph operations order. The purpose of the matrix operations order is to cut orders production time and to provide subordinates more time for reconnaissance, preparation, and rehearsal.
- b. There is no standard format for a matrix operations order. Matrix orders expand on the execution matrix found on many operations overlays. The single-page format may include all signal information for the day of the operation and it can be placed in the corner of a mapcase for easy reference. Matrix orders are usually issued with standard operations, intelligence, and fire support overlays.
- c. Standard agreements with other NATO forces prescribe use of the standard five-paragraph operations order for task forces operating with allies.

TF 2-69 ARMOR DEFENSIVE MATRIX OPORD #1-88 DTG 011000A JAN 88 COPY 21 OF 25 COPIES														
TF CALL SIGN <u>IGN</u> (42.70)				BN MORTAR/FS NET (52.40)				ATTACHMENTS/DETACHMENTS						
CDR <u>16</u> S3 <u>91</u> FSO <u>07</u> MAIN <u>76</u>				BDE FS NET (38.55)				A1-58						
YO <u>34</u> S3A <u>23</u> FAC <u>37</u> PLDR <u>12</u> PSG <u>15</u> AJ1 (48.75)								72 ENG						
S2 <u>39</u> S4 <u>88</u> BMO <u>22</u> ADA <u>VITIS</u> (42.00) AJ2 (45.80)								5x SIGR TMS						
UNIT/STATUS	TM MECH	G	TM TANK	G	Co C	G	Co D	G	SCOUTS	G	72 ENG	G	MORTARS	G
CALL SIGN/PRI	IIM (40.25)		V6D (52.65)		NBY (50.10)		MQU (51.25)		D4I (48.80)		T5V (53.50)		ABE (52.40)	
TASK ORG	1	0	1	0	1	0	1	0	EYES	0	1	0	RED	FDC
	2/8	0	3	0	2	0	2	0	EMS	0	3	0	BLUE	FDC
	2	0	3/1	0	3	0	4	0	3/D	0		0		
	2	0	2	0	3	0		0	5	0		0		
	1	0		0		0		0		0				
TF MISSION: TF 2-69 defends in sector 020600 JAN 88 from (coords) to (coords) and (coords) to (coords) to destroy MRR.														
CORS INTENT: Occupy deception positions along PL DOG; NLT 020400 move to prepared positions along PL CAT; destroy en in EA LION (Ave 1) or EA TIGER (Ave 2) allowing no penetration of PL MOUSE.														
⑤ SP MOVE ORDER ③	6	2	4	7	1	3	5	PRI TO TM TANK						
⑦ OCCUPY PL DOG (DECEPTION) ORIENT ⑨	BP2 TRP1	BP3 TRP2	BP1 TRP1	BP4 TRP2	SCREEN TF FRONT ALONG PL BEAR	PREPARE OBSTACLES ALONG PL CAT	(coords) PRI INIT TO SCOUTS							
① PL CAT (BALANCED ATK) ⑥	BP6 EA LION	BP7 EA TIGER	BP5 EA LION	BP8 EA TIGER	CONTINUE OBSTL AND SURVIVABILITY POSITION WORK		(coords) PRI TM MECH WHEN EN CROSSES PL DOG							
④ MAIN ATK AVE 1 ②	% BP11 AVE 1		BP9 EA LION	SCREEN TF RIGHT FLANK	PRI EFFORT TO BP11	PRI TM MECH								
③ MAIN ATK AVE 2 ⑩	% BP12 AVE 2	BP7 EA TIGER	BP10 EA TIGER	BP8 EA TIGER	SCREEN TF LEFT FLANK	PRI EFFORT TO BP12	PRI TM TANK							
FIRES: 2-10 EA PRI to 2-69	DECEPTION	SKYLINE VL	OF TANKS ON	B3, 12, 3, 34	• Clear TF sector NLT 011400					• Displace by section.				
• PRI INIT SCTS	• OCC BP6	• OCC BP7	• OCC BP5	• OCC BP8	• 3/D OPCN until 112050									
• FPFs: Art. - TM MECH Mort - TM TANK	• RECON BP12	• RECON BP11	• PREP BP10	• PREP BP9	• Five Tgts AB 4002 AB 4003									
• Illum planned on AB 4004, 5, 6, 7, but % TF CDR	• OBSV MAIN	• OBSV NAI2	• OBSV NAI1	• OBSV NAI2	• RENEWSE MUNT BP8 to BP9 AT NIGHT; RPT TIME.									
• FAX AM planned on AB 4004, 5, but % Bde Cdr	• FIRE TGTS: AB 4004 AB 4006	• FIRE TGTS: AB 4005 AB 4007	• RENEWSE MUNT BP5 TO BP10 AT NIGHT; RPT TIME.	• RENEWSE MUNT BP8 TO BP9 AT NIGHT; RPT TIME.	• 3/D ATNS 020500.									
	• CLOSE MINEFIELD AT AB 4006 AFTER SCOUTS PASS THROUGH													
OBSTACLES	MINEFIELD AB 4006	MINEFLD AB 4007	WIRE OBSTL #1	WIRE OBSTL #2						MINEFLD PRI 1- AB 4006 2- AB 4007				
FIGHTING POSN PRI (No.) LOC	#1 (4) BP6	#2 (10) BP7	#3 (8) BP5	#4 (8) BP8						#7 (6) BP5 #8 (6) BP8				
CDR	S3 BP6	MAIN CP (coords) BP7	CBT INS (coords) SOI	UMCP (coords) PYRO MAIN ATK AVE 1 - RED STAR AVE 2 - WHITE STAR	FLD INS (coords) AJ CODEWORD	LRP A 0118M (coords) PIR (1) EN MUNT (2) LAC R ECH	LRP B 021800 (coords) STAND TO 0600 Daily							
ADA	YELLOW TIGHT	HOPP 2	OEG 50cgy	SOI KTV 1062R										

Figure B-6. Example defensive matrix OPORD.

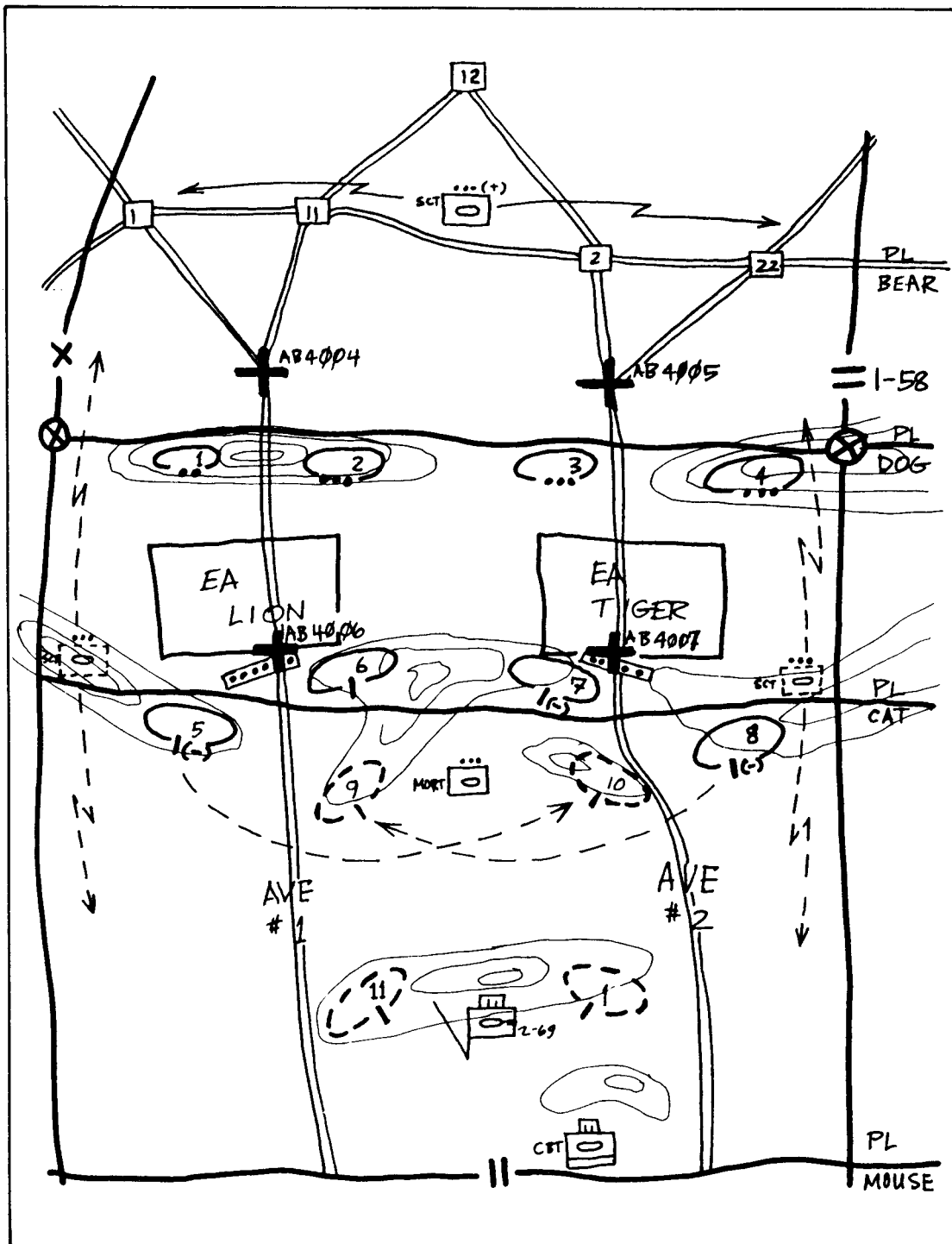

Figure B-6. Example defensive matrix OPORD (continued).

Section IV. OFFENSE OPERATIONS ORDERS

B-15. WARNING ORDER

TO: Orders Group A

FROM: Cdr TF 1-81 INF

SITUATION: One guards tank regiment is attacking along the IRMELSHAUSEN-BAD KONIGSHOFEN-KLEINBARDORF approach as 2d echelon for the 133 TD. The tank regiment is expected to pass through the TD forward regiments and attempt a penetration into the division rear area.

ATTACHMENTS/DETACHMENTS: D/1-25 AR attached to 1-81 Inf effective 020600 Nov 87. D/1-81 Inf attached to 1-25 AR effective 020600 Nov 87.

EARLIEST TIME OF MOVE: Movement to attack positions from current locations is 030400 Nov 87.

NATURE AND TIME OF OPERATION: On order, 03 Nov, TF 1-81 attacks to seize positions to support by fire as TF 1-25 AR conducts the brigade main attack in the east. Continue to attack west on order.

TIME/PLACE OPORD ISSUANCE: TF OPORD will be issued at battalion TOC vic PA067643 at 021200 Nov 87. All addressees attend.

ADMINISTRATIVE/LOGISTICAL INFORMATION: TF XO will coordinate logistical support for D/1-25 AR. All companies will receive a hot meal today. All companies obtain basic CIV load.

Figure B-7. Example warning order (offense).

B-16. FIVE-PARAGRAPH FIELD ORDER

<u>(Classification)</u>	
	Copy <u> </u> of <u> </u> Copies TF 1-81 IN, 3d Bde 52d ID ERDHEIM (PA123456) FRG 021200 Nov 87
OPORD 1-88	
Reference: Map, Series M745, Sheets 5524-5530, 5724-5730, 5924-5930, 6124-6130, 1:50,000.	
Time Zone Used Throughout the Order: Zulu.	
TASK ORGANIZATION:	
Tm A A/1-81 Mech(-) 3/D/1-25 AR 1/C/52 Engr Bn (DS) AVLB	Co E TF Control 1/C/1-441 ADA(DS) Hvy Mortar Plt Scout Plt GSR Tm COLT
Co B	
Co C	
Tm D D/1-25 AR(-) 3/A/1-81 Mech	
1. SITUATION.	
a. Enemy Forces. Annex A (Intelligence Overlay)	
(1) The attacking 1332 Tank Regiment (TR) is the second echelon for the 133 TD. The 1332 TR is expected to	
<u>(Classification)</u>	

Figure B-8. Example five-paragraph field order (offense).

(Classification)

pass through the TD's forward regiments and attempt a penetration of the division rear, vicinity SCHWEINFURT. The enemy TR is estimated at 85% strength. Anticipate regimental reconnaissance elements to be located vicinity PA065750 and PA080753. Disorganized platoon-sized enemy elements may be encountered forward of the LD/LC.

(2) The enemy is capable of being reinforced by a first echelon TR from the second echelon TD within six to eight hours.

(3) Enemy Intentions and Probable Course of Action. Anticipate the enemy TR's main attack to be along the IRMELSHAUSEN (PA047803) - BAD KONIGSHOFEN (PA045733) - KLEINBARDORF (NA999704) approach with two tank battalions (TB) in column. The other first echelon TB is expected to conduct a supporting attack along the HOCHHEIM (PA032803) - AUBSTADT (PA022768) - GROSSEIBSTADT (PA006733) approach.

b. Friendly Forces.

(1) On order, 3d Bde, attacks to defeat an enemy TR vicinity AUBSTADT (PA022768). On order, attacks to establish a defense from NA871801 to PA023696 to defeat an enemy TD. The brigade commander's intent is to destroy the enemy in the HOCHHEIM - BAD KONIGSHOFEN area and then attack to the west to reestablish 1st Bde's original FEBA so the division will be in position to defeat the attacking second echelon TD.

(2) TF 1-78 Mech, on the left, conducts a supporting attack for the brigade to establish a blocking position along HWY 279 from vicinity NA990740 to PA037727 to deny the enemy a penetration south of HWY 279.

(3) TF 1-25 AR, on the right, conducts the main attack for the brigade to defeat the enemy vicinity HOCHHEIM (PA032802) - DORFLESHOF (PA045775).

(Classification)

Figure B-8. Example five-paragraph field order (offense) (continued).

(Classification)

(4) Division air cavalry troops execute forward reconnaissance through the brigade zone. On order, execute screening operations 20-25 kms north of the IGB.

(5) 2d Bde, to the rear, provides rear security for the force.

(6) TF 1-4 AR, brigade reserve, follows TF 1-25 AR and occupies an assembly area vicinity PA130755.

c. Attachments and Detachments. Task Organization.

2. MISSION. On order, TF 1-81 MECH attacks to seize terrain from PA068777 to PA038728; attacks-by-fire to destroy the enemy in the area from PA045775 to PA033744 (EA MULE). On order, attacks to destroy the enemy force in zone.

3. EXECUTION

a. Concept of Operation. Annex B (Operations Overlay). My intent is to use the dominating terrain along the HERBSTADT - BAD KONIGSHOFEN line to support by fire the maneuver of the brigade main effort (TF 1-25). Then, continue the attack to the west to facilitate the brigade's follow-on defensive mission.

(1) Maneuver. TF 1-81 MECH attacks with Tm A, main effort, on axis of advance TRAVIS to seize OBJ LEE. Co B, on order, follows Tm A and seizes OBJ BOWIE. Co C attacks along axis of advance TEXAS; provides overwatch for Tm A from vicinity CPl; on order, continues the attack to seize OBJ HOOD. Co E, on order, follows Co C; upon closure on CPl assumes overwatch mission for Co C and provides overwatch for Co B and Co C; on order, moves to forward firing position. Tm D, task force reserve, follows Co E to occupy an assembly area vicinity PA095760; priority of commitment is to the reinforcement of Tm A. Scout Plt screen forward in zone to PL GRAY.

(Classification)

Figure B-8. Example five-paragraph field order (offense) (continued).

(Classification)

(2) Fires. Annex C (Fire Support Annex). Priority of FA fires from the LD/LC to PL GRAY is to the scout platoon. Tm A has priority of mortar fires. Scout Platoon has two priority Copperhead targets and one FA priority target. Tm A has two mortar priority targets. Battalion COLT move with the scout platoon and occupy a position vicinity PA075733 and prepare to lase priority targets for the scout platoon vicinity objectives LEE and JEB. Scout platoon is responsible for initiating smoke missions to support attacks by Tm A and Co C. A battery, 1-42 FA will be available to provide smoke. Priority of FA fires shifts to Tm A after it crosses PL GOLD. Tm A has two FA priority targets. After Objs LEE and BOWIE are seized and Co C crosses PL GRAY, priority of FA fires is to Tm A, Co C, and Co B, in that order. If the TF receives air assets, priority of fires is to SEAD.

(3) Intelligence and Electronic Warfare. None.

(4) Obstacles, Mines and Fortifications. None.

b. Tm A.

(1) Allow elements from Co E to occupy a portion of OBJ LEE.

(2) Orient fires into EA MULE from TRP#1 to TRP#2.

(3) Be prepared to support by fire a maneuver by Tm D into EA MULE vicinity TRP#2.

c. Co B.

(1) Overwatch the maneuver by Tm A into OBJ LEE from vicinity CP#2.

(2) Defend to retain OBJ BOWIE.

(Classification)

Figure B-8. Example five-paragraph field order (offense) (continued).

(Classification)

- (3) Deny the enemy a penetration of PL GRAY.
- (4) Coordinate with TF 1-78 on the left.
- (5) Orient fires into EA MULE to destroy the enemy from the southwestern boundary of EA MULE to TRP#1.
- (6) Be prepared to attack to seize hills 306 and 297, PA019738 and PA034744, respectively.

d. Co C.

- (1) Provide suppressive fires on OBJ LEE and OBJ JEB.
- (2) Assist Co E in its assumption of the over-watch mission.
- (3) Clear OBJ JEB en route to OBJ HOOD.
- (4) Coordinate with TF 1-25 on the right.
- (5) Orient fires into EA MULE from TRP#1 to the northern boundary of EA MULE.

e. Co E.

- (1) GS to the battalion, priority to the main effort.
- (2) Coordinate with Tm A commander for firing positions within objective area LEE.
- (3) Occupy OBJ JEB with at least one platoon.
- (4) Priority of positioning in the town of HERBSTADT in objective area HOOD.

(Classification)

Figure B-8. Example five-paragraph field order (offense) (continued).

(Classification)

f. Fire Support. Annex C (Fire Support Overlay).

- (1) Chemical Fires. None.
- (2) Field Artillery Support.
 - (a) Organization for Combat:
 - 1-42 FA (155, SP), DS, 3d Bde
 - 2-635 FA (155, SP) R, 1-42 FA
 - 2-611 FA (8", SP) GSR, 1-42 FA
 - C/52 MLRS (GS)
 - (b) Special Instructions. PL's GOLD and GRAY are on order coordinated fire lines (CFL).

g. Scouts. On order, screen the battalion right flank from PA102762 to PL GOLD.

h. Mortar Plt (GS).

- (1) Locate initially PA078647.
- (2) On order, occupy position vicinity PA100710.
- (3) On order, occupy position vicinity PA081754.

i. Air Defense.

- (1) Organization for Combat. See Task Organization.
- (2) Protect, in priority, maneuver forces, Bn mortars, CPs, and TF Combat Trains.
- (3) Annex D (Air Defense - Omitted).

(Classification)

i

Figure B-8. Example five-paragraph field order (offense) (continued).

(Classification)

- j. AVLB Section. On order, revert to TF control.
- k. GSR Tm. On order, revert to TF control.
- l. COLT. On order, revert to TF control.
- m. Engineer. None.
- n. Reserve (Tm D, 1-4 Armor).

(1) Be prepared to counterattack by fire and maneuver into EA MULE from vicinity PA065760 to complete the destruction of the enemy.

(2) Be prepared to block possible enemy counterattack along the TRAPPSTADT (PA119756) - EYERSHAUSEN (PA088745) approach.

- o. Coordinating Instructions.

(1) Forward units be prepared to assist movement of TF 1-4 AR if committed into EA MULE.

(2) Do not engage the enemy until two companies have entered EA MULE, unless attacked.

(3) Tm A will initiate fires into EA MULE.

(4) MOPP 2.

(5) ADA weapons control status: Tight.

(6) ADA warning status: Yellow.

4. SERVICE SUPPORT. Annex E (Service Support - Omitted). TF combat trains displace to vic PA075710 after seizure of Objectives BOWIE and LEE. Field trains remain in BSA. Displace o/o.

(Classification)

Figure B-8. Example five-paragraph field order (offense) (continued).

(Classification)

(1) Supply

C1 I - Issue 3 MRE.

C1 V - CSR for TOW missiles in effect except for Tm A. Support Tm A TOW allocation from Co B allocation.

(2) Services

Medical - No change.

Maintenance UMCP located vic PA069710 after Combat Trains displaces.

5. COMMAND AND SIGNAL.

a. Command.

(1) Commander with Co C, initially; will displace forward to vicinity OBJ LEE.

(2) Bn TOC PA067643, initially.

(3) XO with Bn TOC.

(4) Alternate CP is the Combat Trains PA083625.

b. Signal.

(1) Tm A will initiate the main attack.

(2) Current SOI in effect.

(3) CNVs will change daily at 2000 hours.

(Classification)

Figure B-8. Example five-paragraph field order (offense) (continued).

(Classification)

ACKNOWLEDGE.

HAMMER
LTC

HATLEY
S3

Annexes: A - Intelligence Overlay
B - Operations Overlay
C - Fire Support Overlay
D - Air Defense (Omitted)
E - Service Support (Omitted)

(Classification)

Figure B-8. Example five-paragraph field order (offense) (continued).

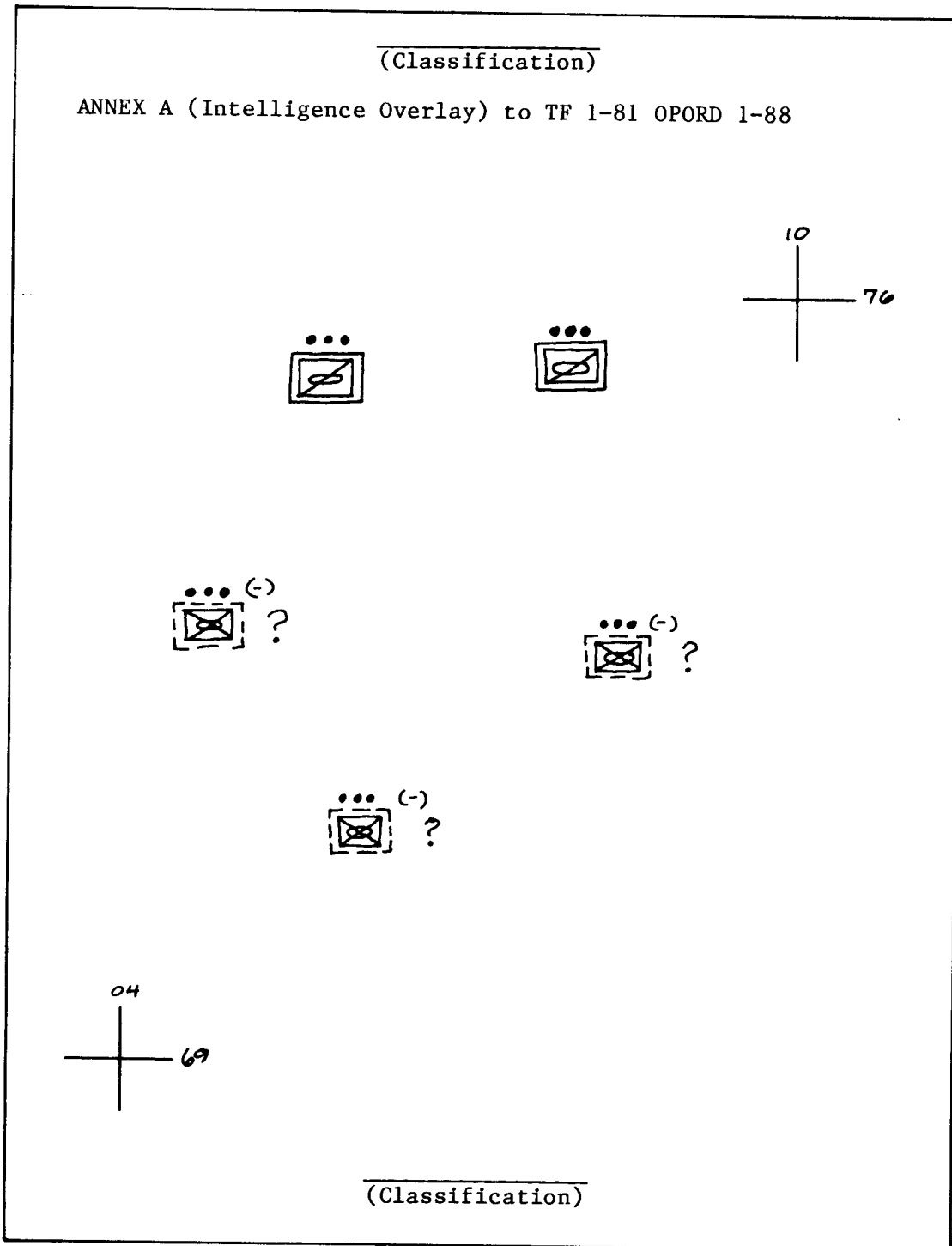

Figure B-8. Example five-paragraph field order (offense) (continued).

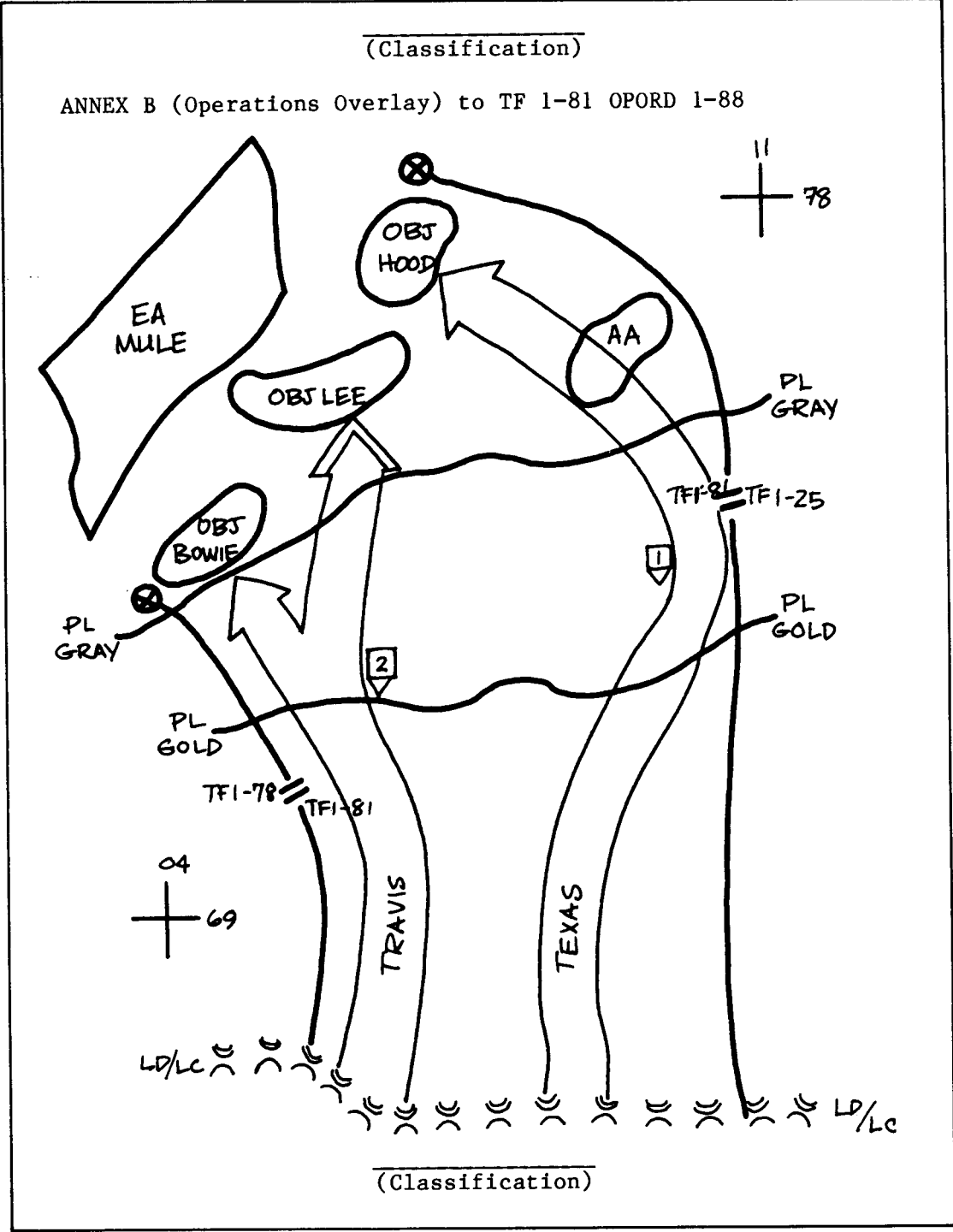

Figure B-8. Example five-paragraph field order (offense) (continued).

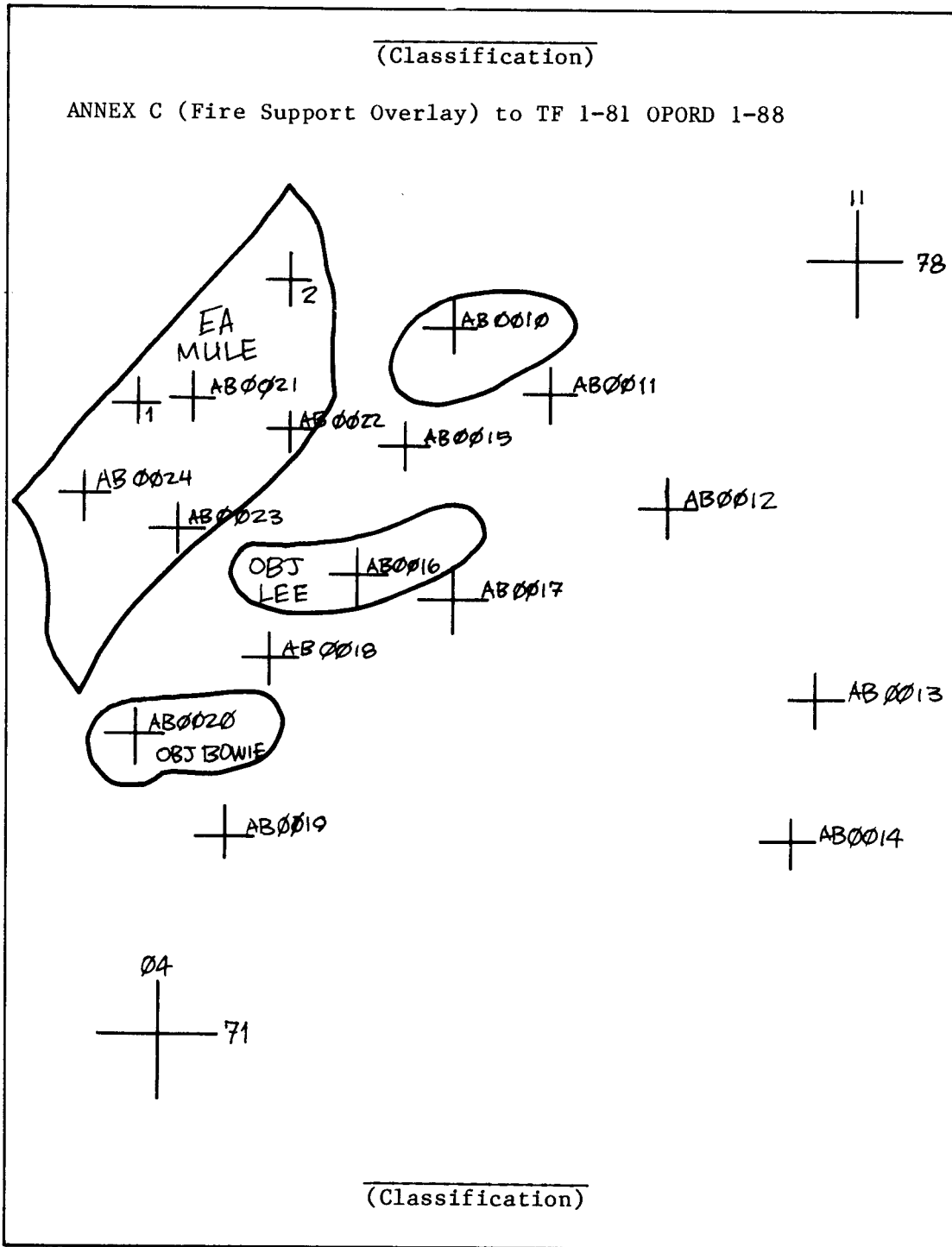

Figure B-8. Example five-paragraph field order (offense) (continued).

B-17. FRAGMENTARY ORDER

a. Oral FRAGO.

"X-Ray, this is X66."
"FRAGO."
"Estimated enemy company on high ground to the right in hasty positions vicinity FL809562."
"A45 and J45, action right; seize high ground vicinity FL809562."
"W45, support by fire from CP7."
"M45, follows A45 and J45; on order, continue the attack along axis from FL809562 to CP 13."

Figure B-9. Example FRAGO issued over secure radio (offense).

b. Written FRAGO.

<u>(Classification)</u>		
(No change from oral orders.)		
		Copy No 2 of 14 copies TF 3-78 WIPPERSHEIM (MB5431) 310500Z Aug 85 MDK
FRAGO 1		
TASK ORGANIZATION:		
TM A A/3-78 MECH (-) 1/D/3-4 ARMOR	TM B B/3-78 2/D/3-4 ARMOR	CO C
TM D D/3-4 ARMOR (-) 1/A/3-78 MECH	CO E	TF CONTROL SCOUT PLT HEAVY MORTARS 1/A/23D ENGR (DS) CEV AVLB
1. SITUATION		
a. Enemy Forces.		
(1) BMP-1981 equipped platoons, reinforced with T-64 tanks, are occupying defensive positions vic MB960196 and MB97193.		
(2) The enemy intends to establish company and platoon sized strongpoints blocking the high speed western approaches to the Ohm River in order to establish his main defense along the eastern bank of the Ohm.		
<u>(Classification)</u>		

Figure B-10. Written fragmentary order (offense).

(Classification)

(3) Elements of a tank company from the regiment's tank battalion constitute the most serious counterattack force. This element is located vic MARDORF (MB9411).

b. Friendly Forces.

(1) 1st Brigade attacks 311015 Aug with the intent of rapidly destroying enemy forces in order to quickly seize crossing sites on the Ohm River from SCHWEINSBERG (MB9724) to HOMBERG (MB9919) and continues the attack north across the river.

(2) TF 3-79 attacks 31095Z Aug to destroy enemy forces vic OBJ BAT (MB9120).

(3) TF 3-4, as the brigade supporting attack, attacks 310945Z Aug to destroy enemy forces vic OBJ GLOVE (MV9719).

(4) TF 3-5 is the brigade reserve. Priority of commitment is to our task force zone.

c. Attachments and Detachments: Task Organization.

2. MISSION

TF 3-78 attacks 311015Z Aug to destroy enemy forces vic OBJ BALL (MB955196 to MB966194); on order, seize crossing sites on the Ohm River vic OBEROFLEIDEN (MB991205) and continue the attack north.

3. EXECUTION

a. Concept of the Operation. Annex B (Operations Overlay). TF 3-78 attacks OBJ DOG (MB955197) and OBJ CAT (MB965195) with the intent of rapidly destroying the enemy forces by envelopment in order to quickly seize crossing sites on the Ohm River and continue the attack north.

(Classification)

Figure B-10. Written fragmentary order (offense) (continued).

(Classification)

(1) Maneuver. Tm B, the TF main attack, attacks to destroy enemy forces and seize OBJ DOG (MB955197), followed by Tm A, which occupies BP3 to protect the TF against probable counterattacks from the north and Co C, the TF reserve. Upon destruction of enemy forces vic OBJ DOG, Co C, now the TF main attack, passes around Tm B to destroy enemy forces on OBJ CAT (MB965195). Tm D, supports by fire from PL HIT, the main attack on OBJ DOG and then on OBJ CAT.

(2) Fires.

(a) Priority target is target group A2B. Tm B Commander will control.

(b) Target series HANK is planned to suppress enemy positions vic OBJ DOG and OBJ CAT.

(c) Priority of Fires.

1 FA to Tm B initially, o/o Tm A.

2 Hvy mortars to Tm D initially, o/o Tm B, then Co C.

b. Tm A. Be prepared to assist Tm B in the seizure of crossing sites on the Ohm.

c. Tm B. On order, seize crossing sites on the Ohm vicinity of OBER OFLEIDEN (MB991205).

d. Co C.

(1) On order, provide guides to assist in the forward passage of either Tm D or TF 3-5 at contact Point 1.

(2) Be prepared to assist Tm B in the seizure of OBJ DOG and crossing sites on the Ohm.

(Classification)

Figure B-10. Written fragmentary order (offense) (continued).

(Classification)

e. Tm D.

(1) Be prepared to assist Co C in the seizure of OBJ CAT.

(2) Be prepared to provide guides to assist the forward passage of TP 3-5 at contact Point 1.

f. Co E.

(1) Priority to Tm B's attack on OBJ DOG then Co C on OBJ CAT from vic PL HIT.

(2) Establish and maintain contact with TF 3-4 on our southeast.

(3) Be prepared to support by fire Tm D's attack across the Ohm vic PL BUNT.

g. Scouts.

(1) Screen TF northern flank from LD to PL HIT.

(2) On order, screen northern flank from PL HIT to PL UNICORN.

(3) Coordinate with Tm A on screen positions.

(4) Recon bridges vic CP11 and CP12 and look for ford sites in zone.

h. Hvy mortars.

(1) Initial location vic MB910143.

(2) Displace by section when Tm D reports crossing PL FLY.

(Classification)

Figure B-10. Written fragmentary order (offense) (continued).

(Classification)

i. Engineers (GS).

- (1) Priority to Tm B, then Co C after seizure of OBJ DOG.
- (2) Priority of work is to forward mobility of maneuver units and crossing of the Ohm River.
- (3) Move with Tm B.
- (4) Support Tm A with assets to prepare point obstacles to protect the TF northern flank from probable counterattack.
- (5) Have AVLB move with Tm D.

j. Reserve: Tm D is reserve after seizure of OBJ DOG. As reserve, be prepared to continue attack across the Ohm River to seize an objective vic CP17 in order to protect our bridgehead against probable counterattacks from the east and the north.

k. Coordinating Instructions.

- (1) MOPP Level 2 in effect.
- (2) AD Warning/Weapons Control Status:
YELLOW/TIGHT.
- (3) OEG: negligible risk.
- (4) Consolidation.
 - (a) Tm A occupy BP3; orient from TRP 004 to TRP 006.
 - (b) Tm B occupy BP2; orient from TRP 008 to TRP 007.

(Classification)

Figure B-10. Written fragmentary order (offense) (continued).

(Classification)

(c) Co C occupy BPl; orient from TRP 006 to TRP 008.

(d) Tm D occupy current positions along PL HIT. Orient fires from TRP 001 to TRP 003.

(e) Co E. Integrate platoons into BPs 1, 2, and 3. Cover from TRP 004 to TRP 007.

Acknowledge:

SCHOTT
LTC

OFFICIAL

WOOLRIDGE
S-3

ANNEXES

Annex A - Intelligence Overlay
B - Operations Overlay
C - Fire Support Overlay

(Classification)

Figure B-10. Written fragmentary order (offense) (continued).

(Classification)

Annex B - Operations Overlay.

	Tm A	Tm B	Co C	Tm D	Co E	SCOUTS	MORTARS	I/A 23 ENGR
SEIZE DOG	FOLLOW Tm B	MAIN ATK SEIZE DOG	RESERVE FOLLOW Tm A	SPT BY FIRE W/L PL HIT	ESTABLISH CONTACT W/ R G'S SPT BY FIRE.	SCREEN W. FLANK LD TO PL HIT	PRI TO Tm B MB 910143	PRI TO Tm B PRI OF EFFORT MOB
			BE PREP. TO ASSIST Tm B		DOG		DISPLACE BY SECTION	AVL6 TO Tm D MOVE W Tm B
SEIZE CAT	MOVE TO BP 3	CONSOL. DOG	MAIN ATK; SEIZE CAT	SPT BY FIRE PL HIT	SPT BY FIRE CAT	SCREEN HIT TO UNICORN		
CONSOLIDATE	DEFEND BP3 004-006	DEFEND BP2 006-007	DEFEND BP1 006-008	RESERVE (PL HIT) 001-003	PLTS TO BP1,2,3 004-007	COORD W/ Tm A		ASSIST Tm A CM BP3
O/O SEIZE CROSSING SITES			ONLOOK AT CP 1			RECON BRIDGES CP 11, CP 12		PRI OF EFFORT MOB (CROSSING)
	BE PREP TO ASSIST Tm B	O/O SEIZE X-MG SITES	BE PREP TO ASSIST Tm B	BE PREP TO SEIZE CP 17		RECON FORDS IN ZONE		
O/O ATK CP 17		CONSOLIDATE X-MG SITES	PASS Tm D OR TF 3-5					
				O/O PROTECT CAT TO N & E				

(Classification)

Figure B-10. Written fragmentary order (offense) (continued).

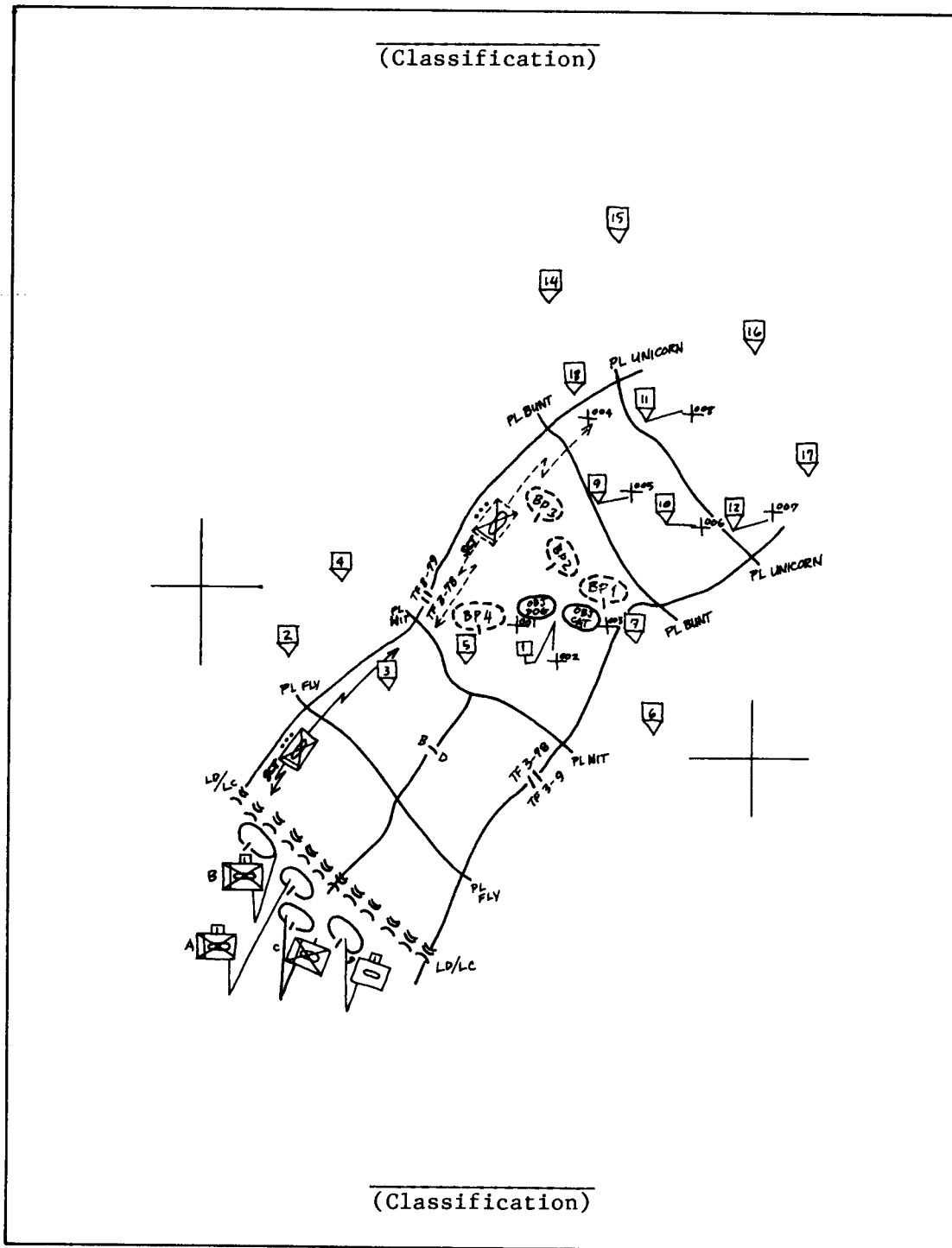

Figure B-10. Written fragmentary order (offense) (continued).

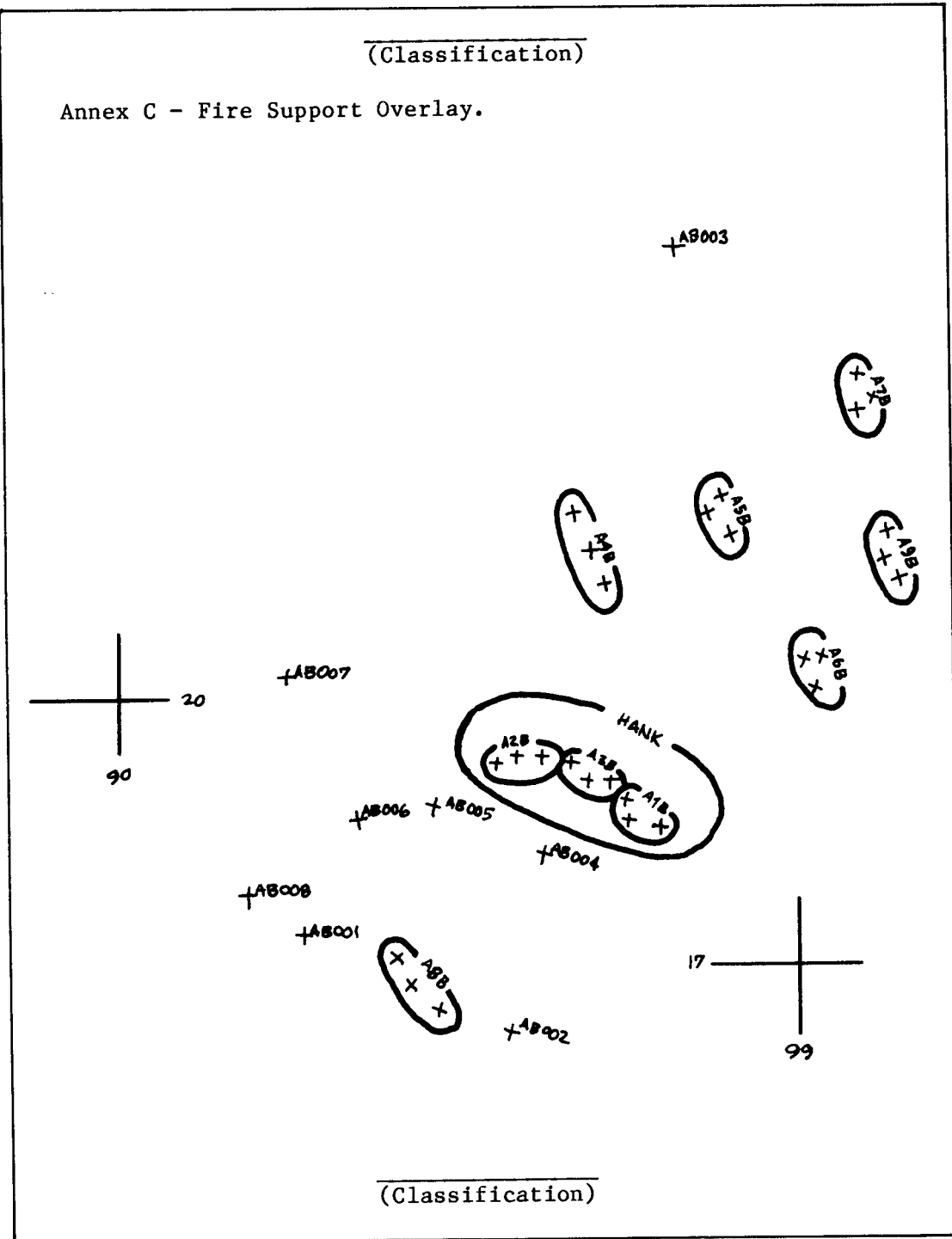

Figure B-10. Written fragmentary order (offense) (continued).

B-18. MATRIX OPERATIONS ORDER

TF 2-69 ARMOR OFFENSIVE MATRIX OPORD #2-88 DTG 020830A JAN 88 COPY 3 OF 25 COPIES														
TF CALL SIGN <u>QGE</u> (37.05) BN MORTAR/FS NET (49.60) BDE FS NET (37.50)						ATTACHMENTS/DETACHMENTS								
CDR <u>50</u> S3 <u>01</u> FSO <u>96</u> MAIN <u>43</u>		XO <u>76</u> S3A <u>01</u> FAC <u>28</u> PLDR <u>85</u> PSG <u>15</u> AJ1 (36.00)		S2 <u>02</u> S4 <u>01</u> BMD <u>68</u> ADA <u>Y4P15</u> (52.00) AJ2 (33.70)		A1-58 -3/72 ENG		C11-58 -LXCEV		5-STAR -LXANLB				
UNIT/STATUS	Co A	G	Co B	G	Co C	G	Co D	G	SCOUTS	G	3/72 ENG	G	MORTARS	G
CALL SIGN/FREQ	PSM (41.00)		N5W (36.10)		COX (51.25)		T9K (52.10)		K9T (38.70)		F90 (39.00)		D8L (49.60)	
TASK ORG	1	2	3	4	5	6	7	8	9	10	11	12	13	14
② LD	AA TO LD	4	B31200	2	7	6	1	5	3					
④	LD TO OBSTL	A1	B1	C1	D1			OBSTL	SMOKE					
⑥	OBSTL TO OBJ CAT							LEAVE GUIDE AT OBSTL						
⑧	ASLT ACTIONS ON OBJ CAT	A2	B2	C2	D2			PLACE OP AT CP 60	PROVIDE GUIDES AT OBSTL	SMOKE / HE MIX				
⑩	CONSOLIDATE OBJ CAT	A2	B2	C2	D2			ESTAB SCREEN 4KM E OF RTE BLUE	.5KM W OF A2	.5KM W OF B2				
FIRES: • PRI INIT SCTS THEN LEAD CO (A) • FA PRI TGT TO CO A • ILLUM O/O TF CDR • 10 MIN CONVENTIONAL PREP OBJ CAT BEGINS 0/0 A CO • ACA WHITE O/O, N. OF GRID 32 • INITIATE 10 MIN FA PREP OF OBJ CAT • LIFT PREP W/GREEN STAR CLUSTER • ATTCHED ENG SOLD TO MARK BYPASS OR LANES MADE BY STEALTH BREACH. • RPT ALL AT POSITIONS, ORIENTATIONS, OBSTACLES. • PRE-LD UPDATE TO S2 AT R31100														
CDR BEHIND LEAD CO (INIT A CO)	S3 INIT AT LD	MAIN CP	OBJ TNS	UMCP	FLD TNS	LRP A O/O	LRP B-MSR							
ADA YELLOW HOLD	HOPP 2	08G	SOL	PIRO Gr Star	AJ CODEWORD	PIR EN POSN?	STAND TO							

Figure B-11. Offensive matrix OPORD.

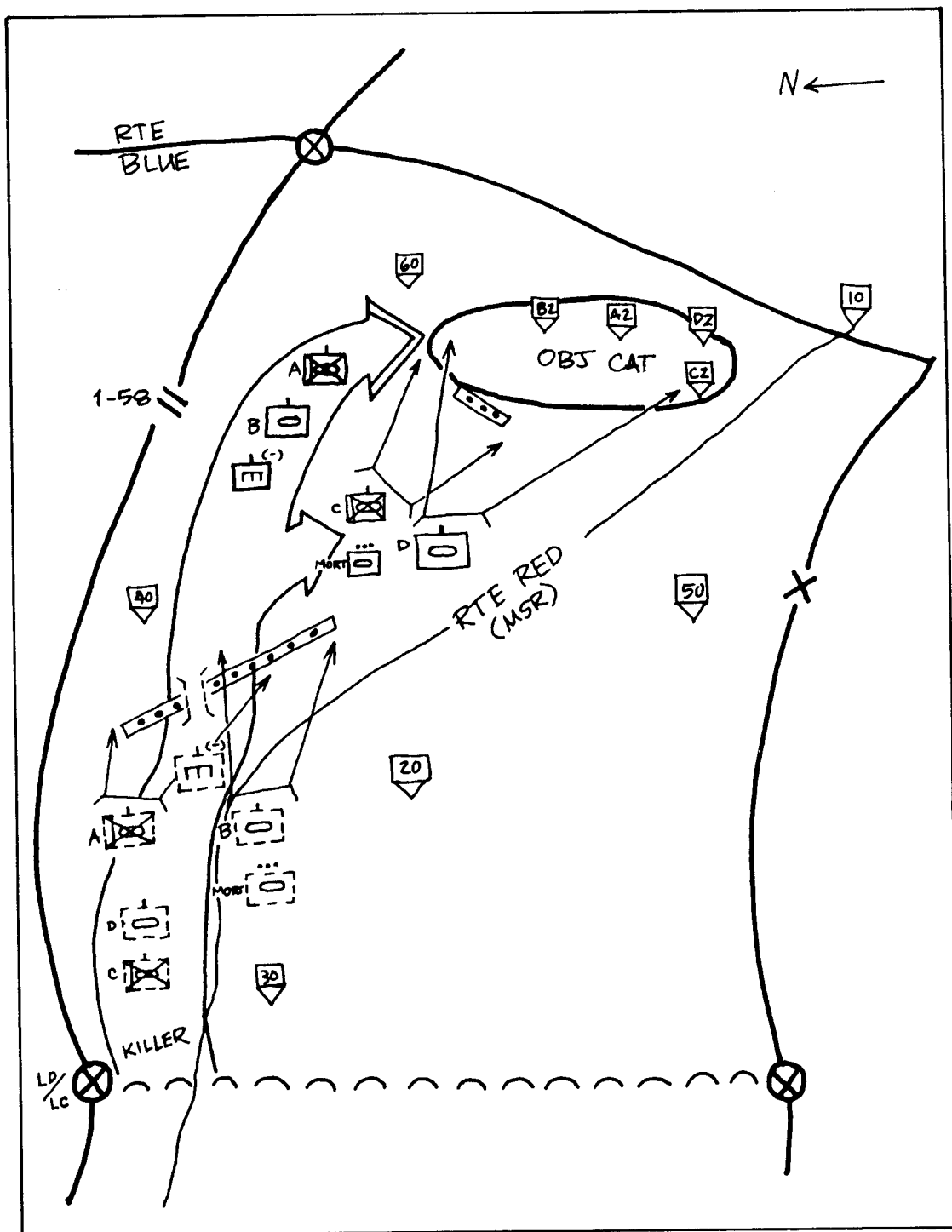

Figure B-11. Offensive matrix OPORD (continued).

APPENDIX C

TACTICAL ROAD MARCHES AND ASSEMBLY AREAS

The movement of troops from one location to another is inherent in any phase of a military operation. Nontactical movement is conducted when contact with the enemy is unlikely. Tactical movement is conducted when contact with the enemy is possible.

CONTENTS	
PARAGRAPH	PAGE
Section I. MOVEMENT	C-1
C-1 Types of Movement	C-1
C-2 Nontactical and Tactical Movements	C-2
Section II. TACTICAL ROAD MARCHES	C-2
C-3 Organization for Road Marches	C-3
C-4 Planning	C-5
C-5 March Order	C-5
C-6 Road March Planning Factors	C-6
C-7 Control Measures	C-8
C-8 Road March Techniques	C-9
C-9 Application of Movement Formulas	C-11
C-10 Road Movement Table	C-14
C-11 Security	C-14
Section III. OCCUPATION OF AN ASSEMBLY AREA	C-24
C-12 Quarters Party	C-24
C-13 Organization	C-25
C-14 Departing an Assembly Area	C-26

Section I. MOVEMENT

The accomplishment of a unit's mission is directly related to its ability to arrive in effective fighting condition at the proper place and time.

C-1. TYPES OF MOVEMENT

- a. Once a unit is deployed in its assigned zone or sector, it normally moves using the techniques appropriate for a movement to contact. At other times, especially when extended distances are involved, more rapid and controlled techniques must be employed

for foot or motorized tactical marches. When contact is made, tactical movement becomes maneuver.

- b. Road marches differ from movements to contact in that—
 - The purpose is relocation, not contact with the enemy.
 - A prescribed rate of speed is ordered before departure, and prescribed intervals are maintained between vehicles and units.
 - The primary consideration of the march is rapid movement.
- c. The task force may also move by air, rail, or water, but for discussion of those kinds of movement, see—
 - Air movement — FM 55-9; FM 55-12; FM 100-27.
 - Rail movement — FM 55-20.
 - Water movement — MTMC Report TE 80-01-46.
 - Also for unit movements — FM 55-65 and AR 55-113.

C-2. NONTACTICAL AND TACTICAL MOVEMENTS

- a. Movement in the communications zone (COMMZ) to reposition laterally or to facilitate future operations is nontactical. The task force S4 may plan nontactical movements. If a unit moves forward to participate in imminent combat operations, the movement is tactical. The task force S3 plans tactical movements.
- b. The task force conducts tactical road marches when relocating in the combat zone in the division and corps rear areas before hostilities begin or when a forward defense has been established. Units move by tactical road marches to rear tactical assembly areas, where they prepare to conduct combat operations. Speed is essential, but security requirements are greater than those for a nontactical movement, even though contact with enemy ground forces is not expected. During tactical movements, the commander is always prepared to execute maneuver.

Section II. TACTICAL ROAD MARCHES

A march column includes all elements using the same route for a single movement under control of a single commander. A task force may march over multiple routes to reduce closing time. A large column may be composed of a number of subdivisions, each under the control of a subordinate commander. March columns regardless of size are composed of four elements: reconnaissance party, quartering party,

main body, and trail party (see Figure C-1). March columns are organized to maintain unit integrity and to maintain a task organization consistent with mission requirements.

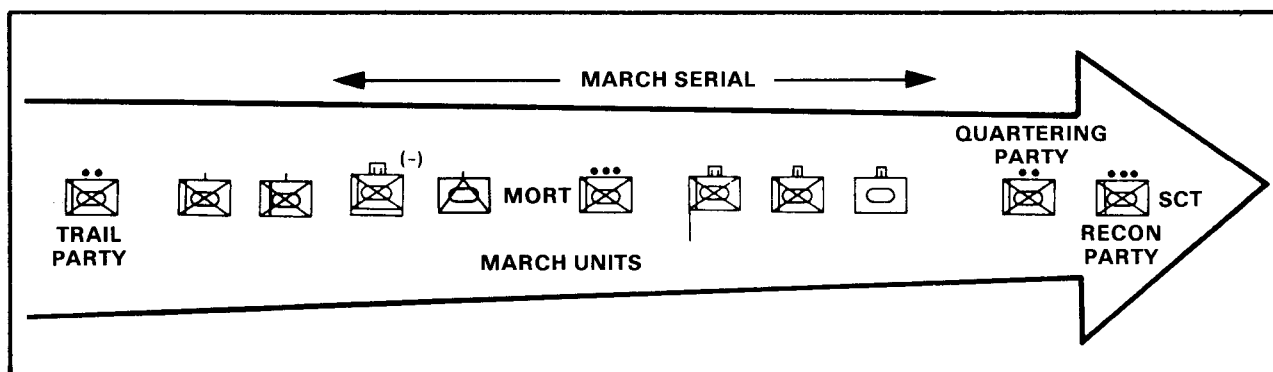

Figure C-1. Organization of battalion tactical road march.

A **serial** is a major subdivision of a march column, organized as a single unit under one commander for purposes of planning, regulation, and control. A task force is usually one serial.

A **march unit** is a subdivision of a serial and is normally a squad, section, platoon, or company. It moves and halts under control of a single commander using voice and visual signals. Radio is used only when no other means of communication can be used. March units of the main body are composed of individual maneuver units with their trains, task force mortars, any attachments, the task force CP, and the task force trains. POL vehicles required for refueling during nontactical marches may move ahead of schedule to establish a service station refuel point.

C-3. ORGANIZATION FOR ROAD MARCHES

- a. **Reconnaissance Party.** The scout platoon, augmented by engineer and other CS assets, performs route reconnaissance to determine travel time, capacities of underpasses and bridges, and locations of ferries and fords. The scout platoon also identifies critical points, including choke points and obstacles. Route reconnaissance confirms and supplements data from map studies, higher headquarters, and air reconnaissance. Instructions to the scout platoon should state the nature and extent of information required, and the time and place the report is to be submitted.
- b. **Quarterming Party.** The quarterming party consists of the quarterming parties of each of the companies. The commander

dispatches a quartering party to reconnoiter the new area and guide march elements into position. (For more detailed information, see paragraph C-13.)

c. **Main Body.**

- (1) Before starting a march, each march unit of a serial reconnoiters its route to the start point and determines the exact time to reach it. The movement order states the time that the serial will arrive at and clear its start point. The serial commander then determines and announces the times for march units of his serial to arrive at and clear the start point. Arrival time at the start point is critical. Each march unit must arrive at and clear the start point on time; otherwise, movement of other elements may be delayed.
- (2) During the movement, march units move at the constant speed designated in the order, maintaining proper interval and column gap. Elements in a column of any length may simultaneously encounter many different types of routes and obstacles, resulting in different parts of the column moving at different speeds at the same time. This can produce an undesirable accordion-like action or whip effect. The movement order gives march speed, rate of march, and maximum catch-up speed to ensure safety and to reduce "column whipping." March units report crossing each control point as directed by the march order. During the move, air and ground security are maintained.

d. **Trail Party.** The trail party is normally made up of elements of the task force maintenance platoon.

- (1) The trail party is the last march unit in a task force serial. The trail party consists of elements of the maintenance platoon led by the BMO. The function of the trail party is to recover disabled vehicles. If a vehicle cannot be repaired or towed, the vehicle and crew members are moved off the road into a secure area. The drivers and crew members are left with the vehicle, along with sufficient food and water.
- (2) When vehicles are left behind, the BMO reports the reason and location to the task force S4.
- (3) Once the trail party completes the road march, maintenance priority becomes recovery of disabled vehicles. A tactical road march is not complete until all march units and vehicles arrive at the destination.

C-4. PLANNING

- a. Tactical road marches require extensive planning. The estimate process is used by commanders and staffs to determine how to best execute a move from one point to another. (See Chapter 2.) Road march planning consists of three steps that may be done concurrently: determining requirements for the move, analyzing organic and nonorganic movement capabilities, and establishing unit movement priorities. The following factors are considered in movement planning:
 - Enemy situation and capabilities, terrain conditions, and weather.
 - Organization of the task force.
 - Security measures before and during the movement and at the destination.
 - Assembly of the march units.
 - Loading of personnel and equipment.
 - Actions at the destination.
- b. When the task force prepares for a tactical road march, the following sequence of march planning is used if time permits.
 - Prepare and issue an oral warning order as early as possible to allow subordinates time to prepare for the march.
 - Prepare an estimate of the situation, analyze routes designated by brigade, and specify organization of the march serial.
 - Prepare and issue the march order.
 - Prepare detailed movement plans and assembly area plans.
 - Organize and dispatch reconnaissance and quartering parties as required.

C-5. MARCH ORDER

- a. The march order format is the same for tactical and nontactical movements. It is prepared either as an annex to an operation order, as a separate operation order, or as a FRAGO. An example of an operation order for a road march is in Figure C-10, on page C-19.
- b. The march order should include, as a minimum, a route strip map that identifies critical points, start point (SP) and release

point (RP) times and locations, order of march, maximum catch-up speed, distances to be maintained between vehicles and units, assembly area locations, and instructions on future operations. In designating distance (interval) or density, the planner must know the effect on column length and the time required to move.

- c. The march order also contains a statement of enemy situation, weather, visibility conditions, and the following factors if applicable:
 - Road restrictions and information derived from route reconnaissance.
 - Actions on enemy contact (ground and air).
 - Actions at halts and actions for disabled vehicles.
 - Actions in the assembly area.
 - Procedures for resupply, maintenance, and feeding.
 - Location of leaders and a communications plan.
- d. Much of the information should be part of the unit's SOP. Only exceptions to the SOP should be stated in the order.

C-6. ROAD MARCH PLANNING FACTORS

Movement formulas are applied to known distance, rate, and time data to derive information necessary to prepare a time schedule. The time schedule is used to regulate departures and arrivals of march elements.

- a. **Time and Distance Relationship.** Relationships between time and distance are the basis for march planning. The planner determines how far the column is to travel (distance) and how long it will take to make the move (time). He must also know the space (length of column) the column will occupy on the route and the distance (road gap) or time (time gap) that separates march columns and their elements. Each term used for distance has its corresponding term for time. The length of a column in kilometers has an equivalent pass time in minutes; the road distance in kilometers or miles has a corresponding time distance. The relationship between time and distance in average rate of march is shown in Figure C-2.
- b. **Distance Factors for Road Marches.**
 - (1) Vehicle interval is the distance between two consecutive vehicles of an organized element of a column.

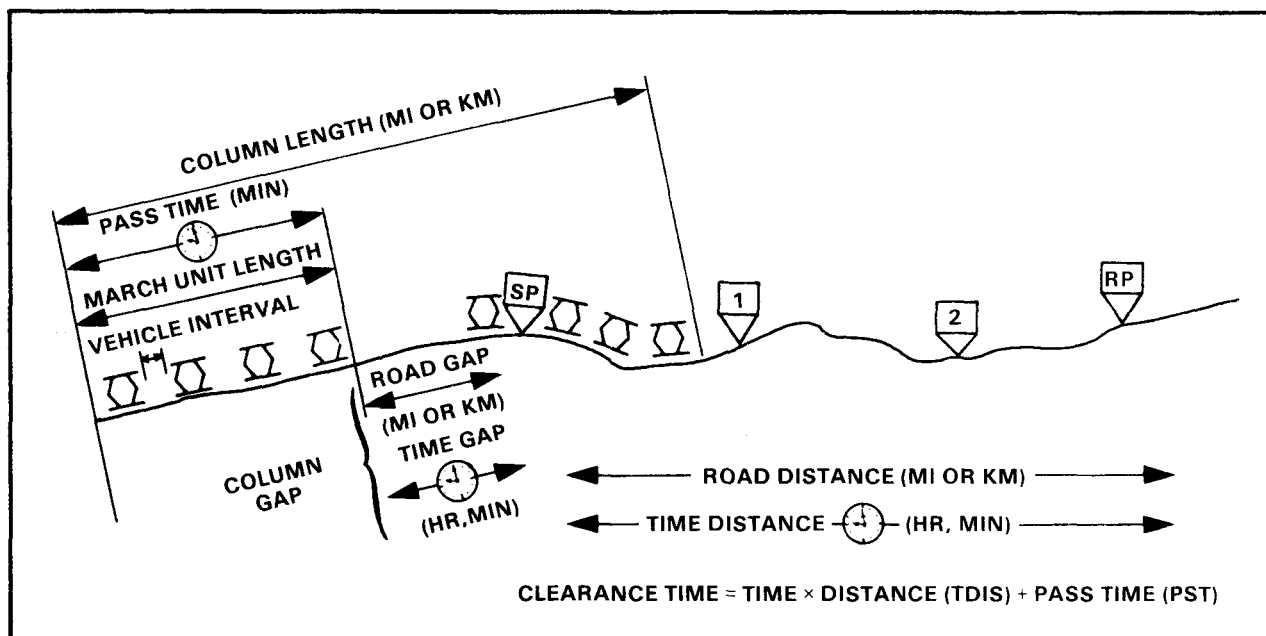

Figure C-2. Time-distance relationships.

- (2) Column gap is space between two organized elements following each other on the same route. It can be calculated in units of length (road gap) or in units of time (time gap) as measured from the rear of the leading element to the front of the following element.
 - (3) Traffic density is the average number of vehicles that occupy 1 mile or 1 kilometer of road space, expressed in vehicles per mile (VPM) or vehicles per kilometer (VPKM).
 - (4) Length of a column is the length of roadway occupied by a column, including gaps in the column measured from first vehicle to last vehicle.
 - (5) Road gap is the distance between two march elements. It is the length aspect of column gap. Since it is more significant when the column is moving than when it is halted, a road gap becomes a factor of time rather than distance.
- c. **Rate Factors.**
- (1) Speed is the velocity of a vehicle at a given moment as shown on the speedometer (in kilometers per hour or miles per hour).
 - (2) Pace is regulated speed of a column or element, set by the lead vehicle or an individual in the lead element, to maintain the prescribed average speed.

- (3) Rate of march is average number of miles or kilometers traveled in any given period, including short periodic halts and other short delays. It is expressed as miles or kilometers traveled in an hour (MIH or KMIH).

d. Time Factors.

- (1) Arrival time is the moment when the head of the column arrives at a designated point or line.
- (2) Clearance time is the moment when the tail of a column passes a designated point or line.
- (3) Completion time is the moment when the tail of a column passes the release point.
- (4) Pass time (PST) of a column is time between the moment the first element passes a given point and the moment the last element passes the same point.
- (5) Extra time allowance (EXTAL) for motor marches of 1 minute per 25 vehicles is always allotted above the calculated pass time within a column moving under one identification serial number. In a column where the number of vehicles is over 600, the EXTAL is 2 minutes per 25 vehicles. A column of less than 25 vehicles is not allotted any extra time. EXTAL is equitably added to march unit pass time within a serial.
- (6) Time distance (TDIS) is time required to move from one point to another at a given rate of march. It normally represents the movement of the head of the column from the start point to the release point.
- (7) Road clearance time is total time a column requires to travel over and clear a section of road. Road clearance time equals time distance plus column pass time.
- (8) Time gap is time measured between rear and front of successive elements as they move past any given point. It is the time aspect of column gap and may also be the conversion of road gap to time. There are no prescribed standard gaps. These depend on the size of serials and march units, the time available for the movement, and the tactics required for protection against air and nuclear attack.

C-7. CONTROL MEASURES

- a. **Critical Point.** Critical points on a route are those points used for reference in providing instructions, places where interference with movement might occur, or places where timing might be

a critical factor. The route reconnaissance report or a map study should provide the march planner with information to designate critical points along the route of march and distances from one critical point to another. At designated critical points, guides or signs may be used to ensure the smooth flow of traffic. The commander may want to be present at the passing of some critical points. The start point and release point are two critical points that are always designated. Critical points are designated by number, letter, or codeword, using the checkpoint symbol. When designating critical points, the march planner ensures that designations for critical points do not conflict with those of checkpoints.

- b. **Start Point.** SPs provide all units of a march column a common point for starting their movement. When units use more than one route, each route has a start point. The SP is a place along the route of march that is easily recognizable on the map and on the ground, such as a road intersection. An SP should be far enough from assembly areas to allow units to be organized and to be moving at the prescribed speed and interval when the SP is reached. No element of a march column should be required to march to the rear or through another unit in order to reach the SP.
- c. **Release Point.** RPs provide all units of the march column a common point for reverting to control of their parent unit. The RP should be on the route of march and easily recognizable on the map and on the ground. Units do not stay at the release point. Guides meet units as they arrive at the release point and lead them to the assembly area. Multiple routes and cross-country movement from the release point to assembly areas enable units to disperse rapidly. No unit should be required to countermarch or pass through another unit to reach its new position.
- d. **Strip Map.** A strip map is a sketch of the route of march. It is normally included as an annex to the movement order. Strip maps should be reproduced in sufficient quantities to supply them to key personnel. The amount of detail depends upon the intended purpose of the strip map and the unit level at which it is prepared. A strip map should contain the start point and release point, restrictions, and critical points, with the distance between them. An example of a strip map is shown in Figure C-3, page C-10.

C-8. ROAD MARCH TECHNIQUES

- a. **Close Column.** In a close column, vehicles are spaced about 20 to 25 meters apart during daylight. At night, vehicles are spaced

so that each driver can see the two lights in the blackout marker of the vehicle ahead. Close column is normally used for marches during darkness under blackout driving conditions. This method of marching takes maximum advantage of the traffic capacity of the routes, but provides little dispersion. Normally, vehicle density is about 30 vehicles per kilometer along the route. A march unit is normally 2 to 4 kilometers long.

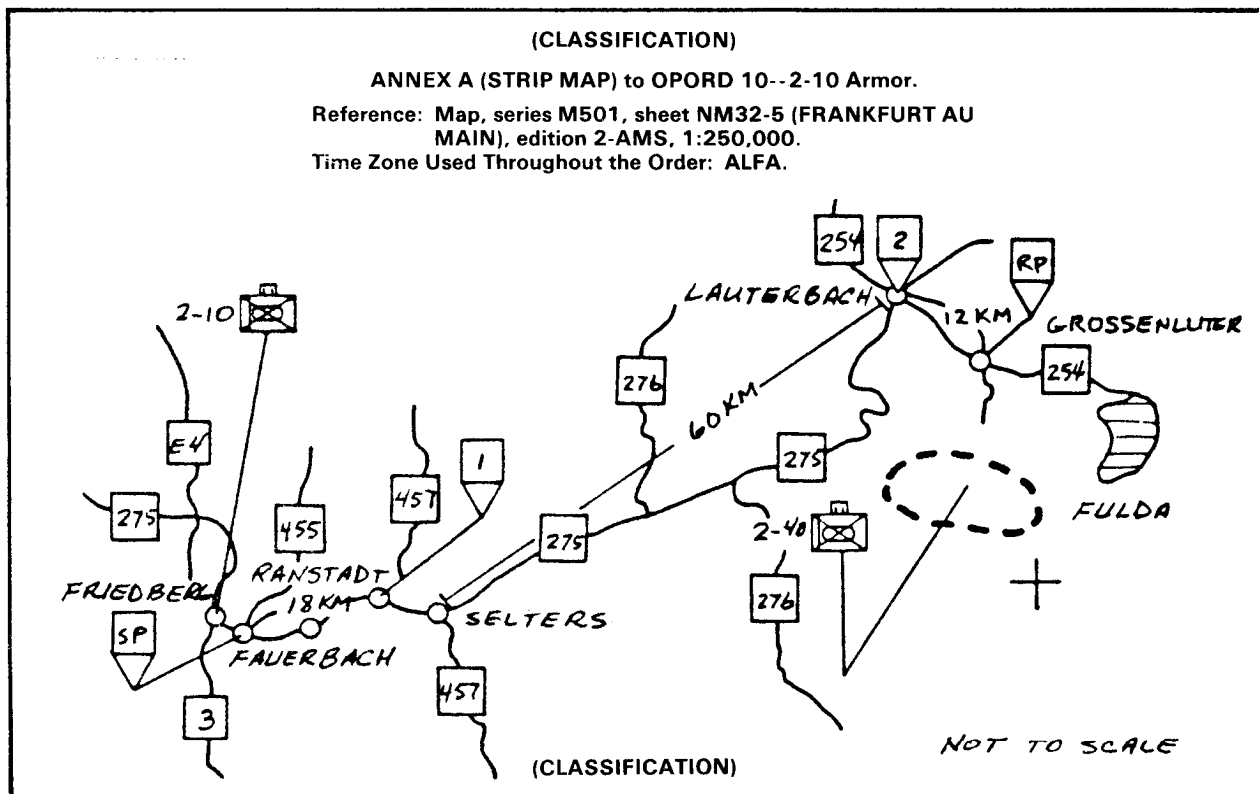

Figure C-3. Strip map.

- b. **Open Column.** In an open column, the distance between vehicles is increased to provide greater dispersion. The vehicle distance varies from 50 to 100 meters. It may be greater if required. Open column is normally used during daylight. It may also be used at night using infrared lights, blackout lights, or passive night vision equipment. Vehicle density varies from 10 to 15 vehicles per kilometer. In a 100-meter open column, a unit is normally 6 to 8 kilometers long.
- c. **Infiltration.** During a move by infiltration, vehicles are dispatched individually, in small groups, or at irregular intervals

at a rate that will keep the traffic density down and prevent undue massing of vehicles. Infiltration provides the best possible passive defense against enemy observation and attack. It is suited for tactical marches when sufficient time and road space are available and when maximum security, deception, and dispersion are desired.

C-9. APPLICATION OF MOVEMENT FORMULAS

This paragraph implements STANAG 2041 (Edition 3), Paragraph 6.

- a. Distance, rate, and time are the basic factors for movement computations. If two of these factors are known, the third may be easily determined by dividing or multiplying one by the other as shown in the following formulas:
 - Rate is determined by dividing distance by time: $R = \frac{D}{T}$.
 - Distance is found by multiplying rate by the time: $D = R \times T$.
 - Time is calculated by dividing distance by the rate: $T = \frac{D}{R}$.
- b. The march planner must determine time distance, pass time, arrival time, and completion time. (See Figures C-4 through C-7, pages C-11, C-12, and C-13.)

TIME DISTANCE FORMULA:

$$TDIS = \frac{\text{DISTANCE (miles or km)}}{\text{RATE OF MARCH (mih or kmih)}}$$

EXAMPLE: Determine TDIS of a serial traveling 135 kilometers at a speed of 24 kmph (rate of march 20 kmih).

$TDIS = \frac{135 \text{ (km)}}{20 \text{ (kmih)}} = 6.75 \text{ hours}$	$\frac{0.75 \text{ (fraction)}}{\times 60 \text{ (minutes)}}$ 45.00 (minutes)
--	--

TDIS = 6 hours and 45 minutes

Figure C-4. Time distance formula.

- (1) **Time distance.** Time distance (TDIS) is determined by dividing distance to be traveled by rate of march. TDIS does not include time for long delays or extended scheduled halts. A time distance table (see Figure C-5) is a valuable tool to the march planner. It provides a listing of factors used to calculate time required to travel certain distances at specified speeds. Travel rates are expressed in speeds and corresponding rates of march. Travel factors are derived from rate of march, which includes time for short, periodic halts and other minor delays that might occur.

SPEED (miles/kilometers per hour)	RATE OF MARCH (miles/kilometers in the hour)	MINUTES TO TRAVEL 1 KILOMETER	MINUTES TO TRAVEL 1 MILE
10 mph 16 kmph	8 mih 12 kmih	5	7.5
15 mph 24 kmph	12 mih 20 kmih	3	5
20 mph 32 kmph	16 mih 25 kmih	2.4	3.75
25 mph 40 kmph	20 mih 32 kmih	1.84	3
30 mph 48 kmph	25 mih 40 kmih	1.5	2.4
35 mph 56 kmph	30 mih 46 kmih	1.3	2
40 mph 65 kmph	33 mih 53 kmih	1.13	1.8

TIME DISTANCE TABLE

This table provides the time required to travel 1 kilometer or 1 mile while using specified march speeds. The travel times are calculated based upon rates of march (miles/kilometers in the hour) and include time for scheduled short halts and time lost due to road and traffic conditions. The time for long halts must be added to the total travel time. Multiply the total distance to be traveled (miles or kilometers) by the travel time factor for 1 mile or 1 kilometer for the designated speed.

EXAMPLE: Determine TDIS for a column traveling 310 kilometers at a speed of 24 kmph. Multiply 310 (km) x 3 (min) = 930 minutes. Convert 930 minutes to 15 hours and 30 minutes.

NOTE: Fractional parts of an hour are converted to minutes by multiplying the fraction by 60 and rounding off to the next higher minute.

Figure C-5. Time distance table.

- (2) **Pass Time.** Pass time (PST) for a serial is determined by adding march unit pass times together, including time gaps between march units. (See Figure C-6.)

PASS TIME FORMULA:

$$PST = \frac{NO\ OF\ VEHS \times 60}{DENSITY \times SPEED} + \frac{NO\ OF\ VEHS}{25} - TIME\ GAPS\ (Min)$$

EXAMPLE: Determine PST of a *serial* of 150 vehicles organized into 6 march units of 25 vehicles each, traveling at a speed of 24 kmph, with a density of 15 VPKM, and using a 2-minute time gap between march units.

$$PST = \frac{150 \times 60}{15 \times 24} + \frac{150}{25} + (2 \times 5) = \frac{9000}{360} + 6 + 10 = 25 + 6 + 10$$

PST = 41 minutes

NOTES: 1. Round off fractions of minutes to next higher minute.
2. EXTAL is allocated on the basis of 1 minute per 25 vehicles added to serial pass time. EXTAL is equitably added to pass time of each march unit in the serial.

Figure C-6. Pass time formula.

- (3) **Arrival time.** In march planning, the release point is normally designated as the terminal point of movement. Arrival time at the release point is determined by adding time distance and any scheduled halts to the start point time. (See Figure C-7.)
- (4) **Completion time.** Completion time is calculated by adding pass time to arrival time or by adding to start point time the distance, pass time, and any scheduled halts.

	<u>Hours</u>	<u>Minutes</u>
SP TIME	08	00
TIME DISTANCE	6	45
SCHEDULED HALT	<u>1</u>	<u>00</u>
	15	45
ARRIVAL TIME IS 1545 HOURS.		

Figure C-7. Determining arrival time.

C-10. ROAD MOVEMENT TABLE

A road movement table is normally an annex to a movement order (see Annex B in Figure C-10, page C-23). It is a convenient means of transmitting to subordinate units time schedules and other essential details of the move. It is particularly useful when the inclusion of such details in the operation order would make the order complicated or unduly long. Road movement tables consist of two parts:

- Data paragraphs reflecting information common to two or more march elements.
- A list of serials or march units, together with all other necessary necessary information arranged in tabular form.

The march planner must know the times at which serials and march units arrive at and clear critical points. Other information on the road movement table includes serial or march unit number, date of move, units involved, number of vehicles, load class of heaviest vehicle routes to be used, and a remarks section to reflect any details not covered elsewhere.

C-11. SECURITY

- a. During the march, march units maintain security through observation, weapon orientation, dispersion, and camouflage. Commanders assign sectors of observation to their personnel so that there is 360-degree observation. Main weapons are oriented on specific sectors throughout the column. The lead elements cover the front, following elements cover alternate flanks, and the trail element covers the rear. Security is also maintained during halts.
 - (1) Scheduled halts are planned along the march route for maintenance and rest, or to follow higher level movement orders. At scheduled halts, vehicles and soldiers move to the side of the road while maintaining march dispersion. Local security is set up immediately, and drivers perform during operations maintenance checks. The unit is ready to move at a moment's notice.
 - (2) Unscheduled halts and actions may be caused by unforeseen developments such as obstacles, traffic congestion, or equipment failure. If a halt is necessary, the march column's first priority is to establish security. Each unit forms a hasty perimeter defense.
- b. Planning for air defense and implementing all forms of air defense security measures are imperative to minimize the battalion's

vulnerability to enemy air attack. The task force commander must be able to effectively integrate into his fire plans the air defense artillery assets attached to him. Furthermore, he must ensure that all passive and active air defense measures that may be implemented at company level are planned and used. Each vehicle in a motor march has an air guard to provide air security. Specific vehicles may be designated as air guard vehicles performing air rather than ground observation.

- c. Obstacles that are reported by the scout platoon should be bypassed if possible. If obstacles cannot be bypassed, the lead march unit goes into a hasty defense to cover and overwatch, and — with engineers, if available — breach the obstacle. As the lead march unit breaches the obstacles, the other march units move at decreased speed or move off the road and monitor the task force command net.
- d. During the road march, should the task force come under attack by enemy indirect fire, the unit in contact continues to move. The remainder of the task force attempts to bypass the impact area (see Figure C-8).

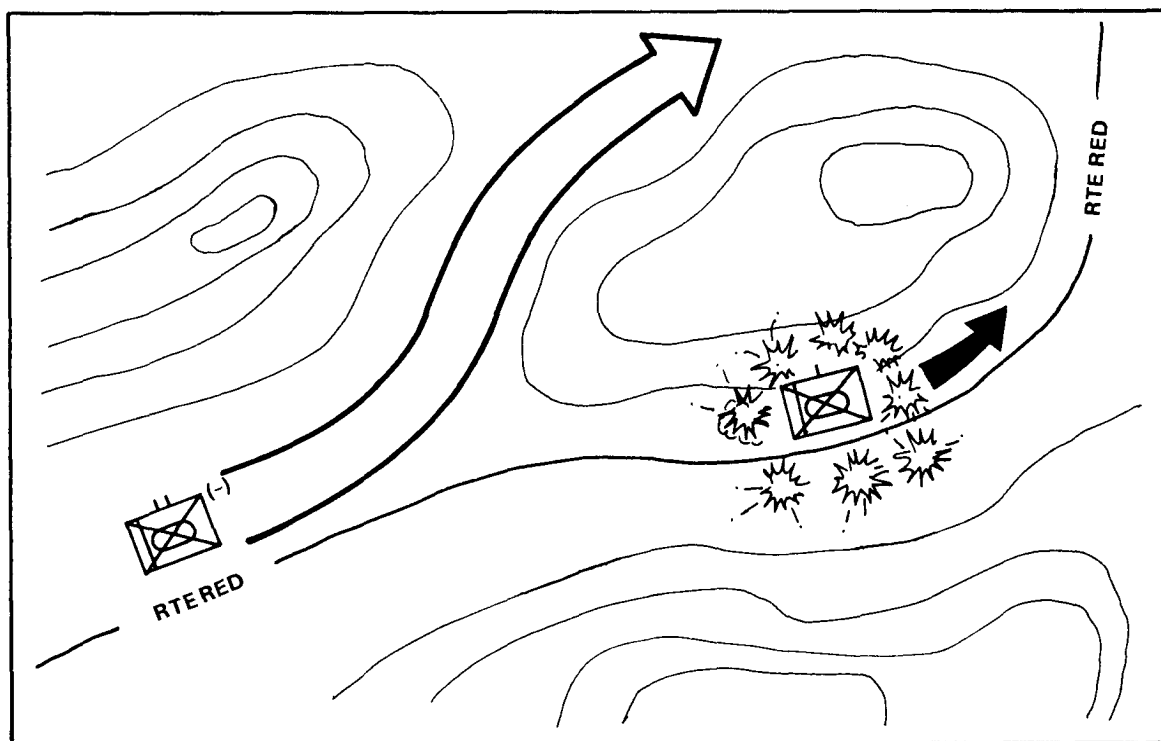

Figure C-8. Actions under indirect fire.

- e. Should the task force be attacked by hostile aircraft during the march, the march unit that is attacked moves off the road into a quick defensive posture and immediately engages the aircraft with all available automatic weapons. The rest of the task force moves to covered and concealed areas until the engagement stops.
- f. Ambushes are fought without delay. If the task force is ambushed, the march unit in the kill zone increases speed, fights through, and reports the ambush. The task force commander may order that march unit to return to the ambush site and conduct a hasty attack to clear it of enemy, or to establish a blocking position on the far side of the kill zone while a following march unit conducts the hasty attack (see Figure C-9).

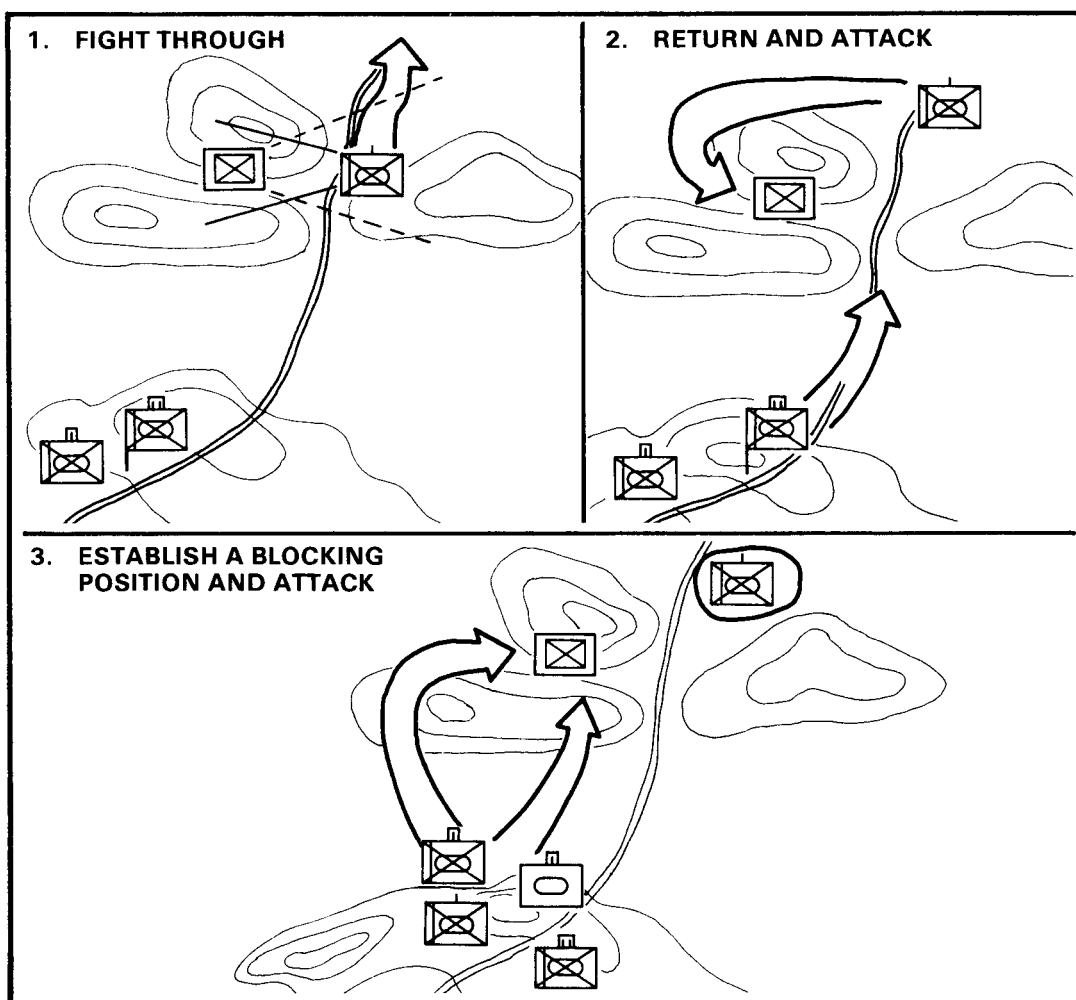

Figure C-9. Actions on ambush.

- g. Disabled vehicles must not obstruct traffic. They are moved off the road and their status is reported immediately. Security is established and guides are posted to direct traffic. If the operator repairs the vehicle, it rejoins the rear of the column. If the operator cannot repair the vehicle, trail party maintenance elements pick it up.
- h. Messengers and visual signals are the preferred means of communication during road marches. Because the enemy has radio direction-finding equipment, the radio is used only in emergencies and when no other means of communication can be used. Road guides can also be used to pass messages from one march unit to a following march unit. Because of the need to stay off the radio, road guides are important in controlling the speed of march units and the interval between them.
- i. Restrictions are points along the route of march where movement may be hindered or obstructed. These points can include bridges, intersections, ferries, and bypasses. The march planner should stagger start times or adjust speeds to compensate for restrictions, or plan to halt the column en route until the restriction is over.
- j. Units must be able to routinely operate under limited visibility conditions caused by darkness, smoke, dust, fog, heavy rain, or heavy snow. Limited visibility decreases the speed of movement and increases the difficulty in navigation, in recognizing checkpoints, and in maintaining proper interval between units. To overcome command and control problems caused by limited visibility, commanders may position themselves just behind lead elements. More restrictive control measures, such as additional checkpoints, phase lines, and use of a single route may become necessary.
- k. The task force commander also plans for NBC attack. Planning considerations include the following.
 - (1) Ensuring that protective and decontamination material is properly distributed and its location known to all in the march unit.
 - (2) Ensuring that proper MOPP level is maintained, based on the threat and the temperature level. Personnel may start in MOPP 3 to avoid having to stop to get into MOPP 4.
 - (3) Avoiding contaminated areas if possible. The following measures apply if contaminated areas must be crossed.
 - Use MOPP 4.
 - Cover as much equipment as possible.

- Avoid moving through underbrush.
 - Stay on hard-surface roads.
 - Avoid low areas.
 - Avoid moving early or late in the day.
 - Stagger vehicles in the column.
 - Decrease speed to reduce dust or mud.
 - Increase vehicle interval.
 - Scrape dirt-road surfaces to clear the road of contamination.
- (4) If soldiers must cross a nuclear contaminated area, measures to be employed include —
- Wearing regular wet weather gear with scarf or handkerchief over nose and mouth.
 - Avoiding stirring up dust as much as possible.
 - Ensuring that the IM-174 radiac meter is used.
 - Washing hard-top roads before traveling.
 - Wetting dirt roads to keep fallout dust down.

(Classification)

Copy No. ___ of ___ Copies
 TF 2-76
 GAY (GL645745)
 211600R Aug 19 ___
 EEL

OPORD 31

Reference: Map, GEORGIA, L7014, 1:250,000, BENNING Sheet,
 2d Edition.

Time Zone Used Throughout the Order: ROMEO

Task Org: Annex B (Road Movement Table).

1. SITUATION

a. Enemy Forces. Current INTSUM.

b. Friendly Forces. 1st Brigade moves 221000 August to
 assembly area vicinity FARGO (GN7512).

c. Attachments and Detachments. A/2-4 Armor and
 1/A/52d Engr attached effective 220430 Aug.

2. MISSION

TF 2-76 moves to assembly area vicinity FARGO (GN7512);
 SP (GL6672) 221159 August; closes assembly area by 221930
 Aug.

3. EXECUTION

a. Concept of Operation. Annex A (Route Overlay). I
 intend to close assembly area during daylight. TF conducts
 a motor march, in six march units via Route RED, first march
 unit crossing SP at 221159 August and last march unit clear-
 ing the release point, vicinity FARGO, by 221830 Aug.

(Classification)

Figure C-10. Example of road movement order.

(Classification)

- b. March Unit 1:
- c. March Unit 2:
- d. March Unit 3:
- e. March Unit 4:
- f. March Unit 5:
- g. March Unit 6:
- h. Coordinating Instructions.
 - (1) Annex B (Road Movement Table).
 - (2) Quartering party assemble at task force CP at 220900 Aug.
 - (3) Vehicle density: open column - 12 vehicles per km.
 - (4) Rate of march: 24 kmph.
 - (5) Time gap: 5 minutes between march units.
 - (6) Vehicle bumper markings will be covered.

4. SERVICE SUPPORT

- a. Supply. Each man draw two MREs at breakfast for noon and evening meal 22 Aug.
- b. Services. Trail party task force control.

(Classification)

Figure C-10. Example of road movement order (continued).

(Classification)

5. COMMAND AND SIGNAL

a. Command.

(1) Commander and march CP at head of march unit 2.

(2) Alternate march CP is Co A HQ.

b. Signal.

(1) SOI Index 1-10.

(2) Panel markings for key vehicles during motor march as prescribed in SOI Item No. 51-1.

(3) Listening silence north of release point.

ACKNOWLEDGE

MARSHALL
LTC

OFFICIAL:

THOMAS
S3

Annexes: A - Route Overlay
B - Road Movement Table

Distribution: A

(Classification)

Figure C-10. Example of road movement order (continued).

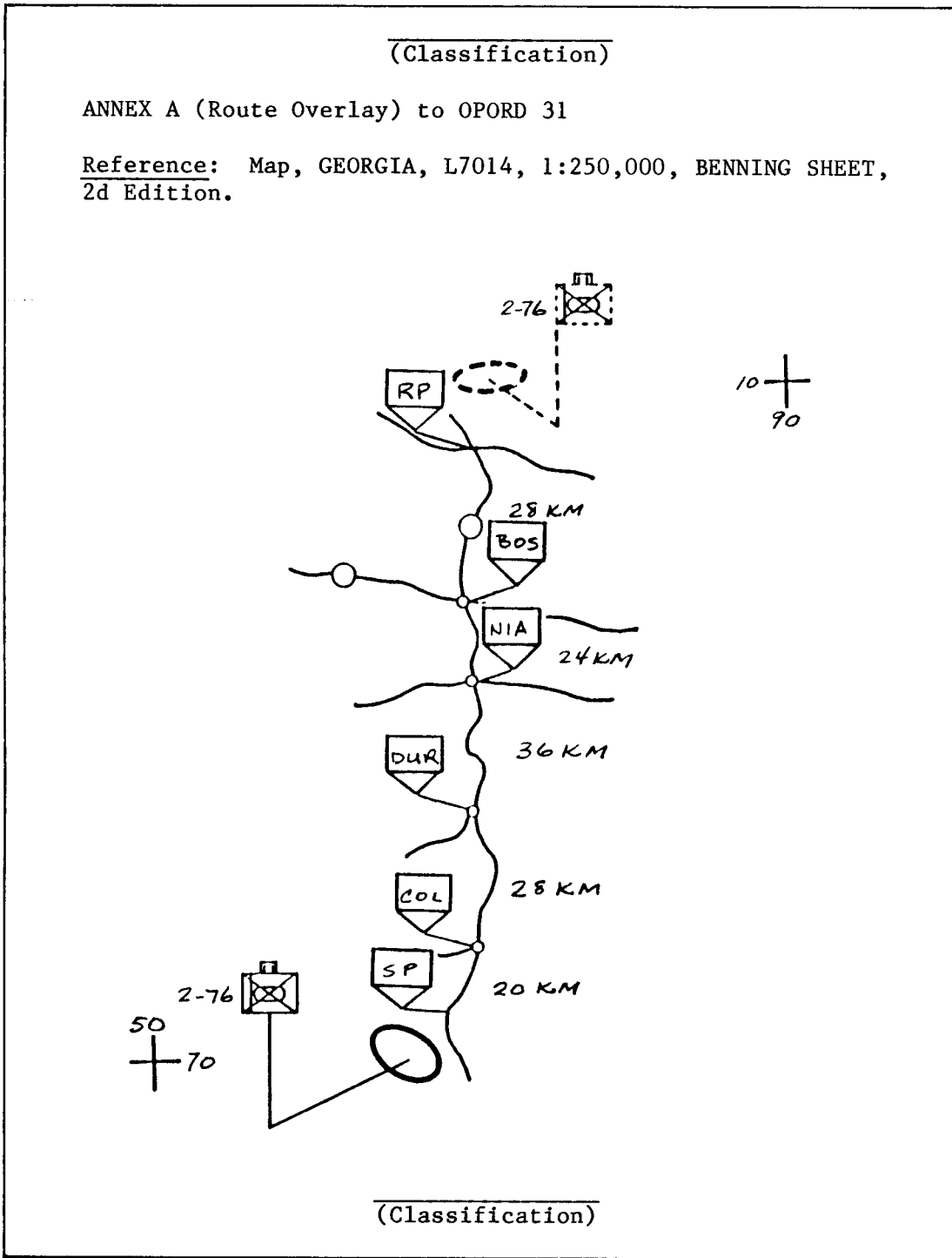

Figure C-10. Example of road movement order (continued).

<u>(Classification)</u>
Annex B (Road Movement Table) to OPORD 31
<u>Reference:</u> Map, GEORGIA, L7014, 1:250,000, BENNING Sheet, 2d Edition.
<u>Time Zone Used Throughout the Order:</u> ROMEO
<u>General Data:</u>
1. Average Speed: 24 kmph.
2. Traffic Density: 12 vpkm.
3. Halts: 1545-1645, meal and fuel; all others SOP.
4. Critical Points: Route RED
a. Start point: AUGUSTA (GL6672) (AUG)
b. Release point:
FARGO (GN7512) (FAR)
c. Other critical points:
COLUMBIA (GL6979) (COL)
DURHAM (GL6989) (DUR)
NIAGARA (GL6893) (NIA)
BOSTON (GN7106) (BOS)
d. Route Classification: 10X50
e. Route restriction: None
5. Main Routes to Start Point: N/A
6. Main Routes to Release Point: N/A
<u>(Classification)</u>

Figure C-10. Example of road movement order (continued).

Section III. OCCUPATION OF AN ASSEMBLY AREA

A battalion task force occupies an assembly area to prepare for future operations. Preparations may include reorganization, issuance of orders, receipt and issuance of supplies, and maintenance of vehicles and equipment.

Occupation of an assembly area may be directed by a higher commander (such as when the unit is designated as a reserve) or by the task force commander (such as during relief, withdrawal, or movement).

The assembly area ideally provides—

- Concealment from air and ground observation.
- Cover from direct fire.
- Space for dispersion against massed chemical or nuclear fires.
- Adequate entrances, exits, and internal routes,
- Good drainage and soil conditions to support battalion vehicles.

A force in an assembly area is provided a degree of security by being behind friendly lines. Despite this protection, the task force must be capable of defending itself should the enemy breakthrough, bypass forward defenses, or insert airborne or airmobile forces. In such a case, the task force normally uses the same techniques that are used in the perimeter defense.

C-12. QUARTERING PARTY

- a. Before the main body leaves the assembly area, the march commander sends a reconnaissance party and a quartering party (or advance party) to the forward assembly area.
- b. The reconnaissance party and the quartering party do not travel as part of the march column. They precede the main body and move by infiltration. The reconnaissance party, normally the scout platoon, checks the area for enemy units or OPs and for NBC contamination.
- c. A task force quartering party is normally composed of a security element, subordinate unit quartering parties, communications and medical personnel, and staff section representatives. An officer, or the CSM, leads the quartering party. On arriving in the assembly area, the quartering party does the following.
 - (1) **Reconnoiters the area.** The quartering party checks for NBC contamination, enemy OPs, trafficability, routes in and out, and cover and concealment.

- (2) **Organizes the area.** The quartering party selects subordinate unit, command post, and trains locations; improves and marks entrances, exits, and internal routes; marks or removes obstacles and mines; and marks vehicle locations.
- (3) **Performs guide duties.** The subordinate unit quartering parties guide task force elements into assigned sectors.

C-13. ORGANIZATION

- a. The assembly area may be organized by assigning companies sectors of the battalion perimeter (see Figure C-11) or dispersed company assembly areas within the battalion assembly area. The task force commander may determine the size and location of his assembly area during the estimate process; or the size and location of the assembly area may be designated by higher headquarters.
- b. Security may be augmented by patrols, OPs, sensors, and surveillance devices. Contact points for units may also be designated to assist in coordinating security efforts. All routes

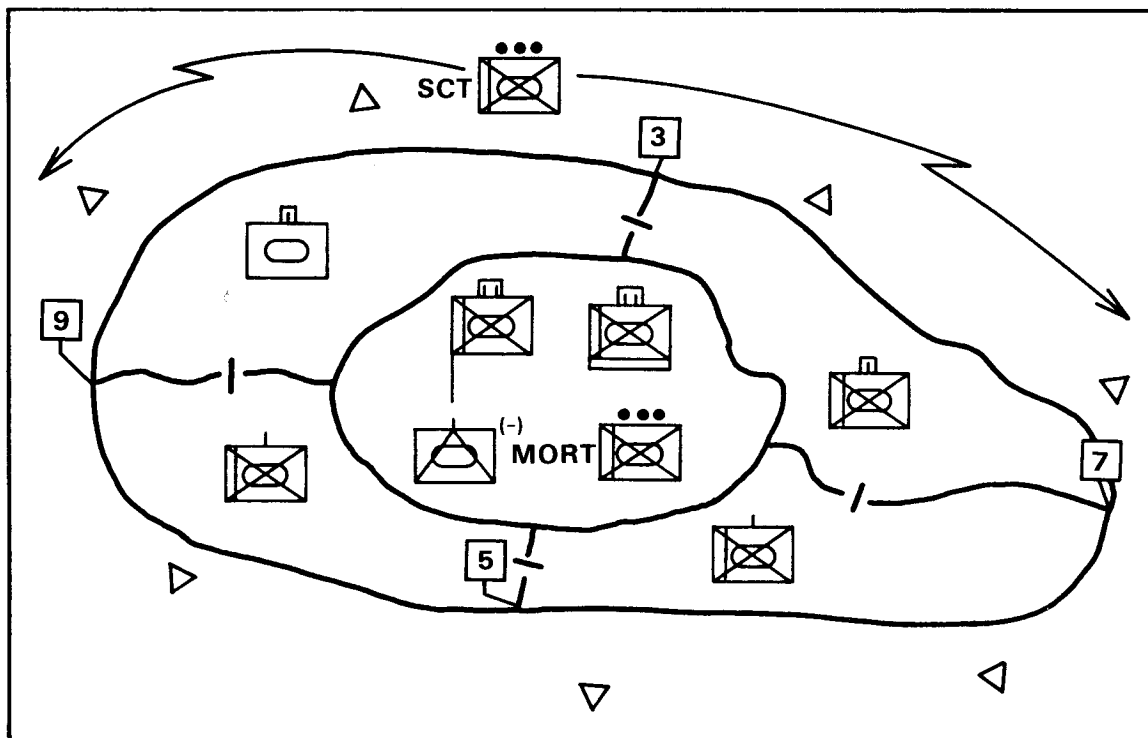

Figure C-11. Assembly areas.

in and out of the assembly area are strictly controlled. Roads are not used to define unit boundaries. Roads are the specific responsibility of the company whose sector they pass through.

- c. The scout platoon may be tasked to reconnoiter routes of movement to attack positions, defensive positions, or passage lanes; or to establish OPs, roadblocks, or traffic control points.
- d. Combat support elements are positioned with units to be supported or may provide support to all elements of the task force.
- e. Company assembly areas should be large enough to allow dispersion and be sited to take advantage of available concealment from observation and cover from enemy direct fires. Their position within the task force assembly area should facilitate movement for future operations.
- f. Observation posts cover key terrain features and avenues of approach.
- g. The task force CP and trains are centrally located for security and to facilitate issuance of orders, distribution of supplies, and other activities.
- h. Communication between elements is by wire (if time allows its installation) or by messenger. Radio is used only in an emergency.

C-14. DEPARTING AN ASSEMBLY AREA

- a. Departure from an assembly area must be as carefully planned and conducted as its occupation.
- b. If terrain permits, vehicles line up in a dispersed movement formation. Commanders ensure that all personnel and equipment have been accounted for and that no equipment, documents, or other items are left behind. This measure is necessary for OPSEC and accountability.
- c. Before movement, messengers from subordinate elements may be stationed at the main CP. Within a few minutes of departure, messengers return to and alert their elements.

* APPENDIX D

DIRECTED-ENERGY WEAPONS

The battlefield of the next war will include directed-energy weapons (DEWs). Several threat weapons have already been tested in combat; improved versions of these weapons may be fielded soon. For the task force commander, the DEW battlefield is here now. It exists in the form of threat weapons that he must be prepared to face today and in the form of our own DEW systems, many of which are already being tested in prototype form. Commanders, S2s, and S3s must understand the nature of the DEW threat and how to defend against it, or it may become an enemy combat multiplier of enormous impact.

CONTENTS	
PARAGRAPH	PAGE
Section I. CHARACTERISTICS	D-1
D-1 Microwave Radiation Emitters	D-2
D-2 Particle Beam Generators	D-2
D-3 Lasers	D-2
Section II. TACTICAL IMPLICATIONS	D-6
D-4 Planning Considerations	D-6
D-5 Actions Under Directed-Energy Weapon Attack ...	D-8
D-6 Treatment of Laser Injuries	D-8
D-7 Laser Mission-Oriented Protective Posture	D-9

Section I. CHARACTERISTICS

DEWs include microwave-radiation emitters, particle-beam generators, and lasers. Conventional weapons rely on chemical or kinetic energy in the form of a projectile. DEWs rely on subatomic particles or electromagnetic waves that impact at or near the speed of light. Since the energy from DEWs travels this fast and is line of sight (LOS), it arrives at the target almost instantly. A DEW gunner need not lead a target, and resupply of ammunition is never a problem. DEWs can attack heavily armored targets at their most vulnerable points—their optics (eyes) and soft electronics.

D-1. MICROWAVE RADIATION EMITTERS

Long-term exposure to high-intensity microwaves may produce physical and psychological effects on humans to include warmth, pain, headaches, fatigue, weakness, and dizziness. Used against equipment, high-intensity microwaves can cause on-board electrical systems to fail; they can severely damage or destroy miniaturized electronic components, such as microchips, by overloading them with electrical energy. Microwave energy also can cause electrically fuzed munitions to become duds or to detonate. This effect depends on the power output of the weapon and the distance to the target.

- a. Protection. The only reliable protection for emitters is completely encasing susceptible equipment in a heavy gauge metal shielding or surrounding it with special metal screening. Burying or covering equipment with sandbags or other nonmetallic materials will not provide adequate protection. On combat vehicles, sensitive components should be left in their proper mounts, and their grounding strap should be checked. Smaller pieces of equipment should be placed in empty ammunition cans. Hatch covers should be kept closed unless someone is entering or exiting the vehicle. EMP follows ground contours, so terrain masking provides some protection.
- b. Countermeasures. Known or suspected locations of enemy ground-based microwave-generating weapons should be attacked by direct and indirect fires. The type of munitions used should be nonsmart rounds that do not require command guidance or triggering at the target location. Microwave radiation weapons can neutralize more advanced munitions by affecting their internal electrical components.

D-2. PARTICLE BEAM GENERATORS

A particle beam is a directed flow of atomic or subatomic particles. These high-energy particles, when concentrated into a beam that can interact with a target, can melt or fracture target material and generate X-rays around the point of impact. If effective particle beam weapons are developed for use in ground combat, the same kind of defensive measures taken against any direct-fire weapon will protect against their effects. Terrain masking is the most effective method available to counter particle beam weapons.

D-3. LASERS

These weapons are the category of DEWs most likely to be used against our forces. Laser weapons produce intense heat and light on a target. Optical devices, specifically vehicle sights and sighting systems, are the most likely targets. Lasers can burn out optical devices and flash-blind those who operate them. However, soldiers are susceptible to laser weapons even when not using optical devices. Laser energy from friendly and enemy systems can damage the

naked eye (damage may be temporary or permanent). Because the eye is more sensitive to light during darkness, laser weapons have a greater effect at night than during the day.

- a. **Direct-View Optical Devices.** A laser weapon targeted on see-through optical devices damages the eyes of the targeted operator. The beam passes through the optical device and burns the eye, causing either temporary loss of vision (flash-blinding) or permanent blindness. When the optical device has a magnifying capability (such as binoculars), the beam strength is magnified, which causes greater injury to the eye (Table D-1).

DIRECT-VIEW DEVICES	ELECTRO-OPTICAL DEVICES
Direct View	Image Intensifiers
Eyeglasses Contact Lenses Sun, Wind, and Dust Goggles Vision Blocks	AN/PVS-4 AN/PVS-5
Magnifying	Thermal Devices
Binoculars (7x) ITV Acquisitions Sight (3x) ITV Squad Leader's Periscope ITV Gunner's Sight (13x) TOW Daysight	Thermal Nightsight AN/TAS-4A Ground laser-location designator (GLLD) M2/M3 integrated sight unit M1A1 tank gunner's primary sight
Infrared Devices	
Infrared TOW Missile Tracker	

Table D-1. Direct-view and electro-optical devices.

- b. **Electro-optical Devices.** A laser attacks a non-see-through optical device by burning the sensor or reticle inside of it, degrading its capabilities. Some of the electrical circuitry inside the device also may be damaged by the heat surge. However, lasers do not affect the operators of non-see-through optical devices.
- c. **Hazards.** Soldiers should be aware of the potential hazards from laser devices, which are currently available in the US Army inventory. Just as a commander plans his unit fires to avoid the hazard of fratricide, he must likewise plan his laser fires.
- (1) Devices most likely to be found near friendly troops are *laser range finders*. Laser range finders are used on the M60A3 and M1 tanks, and they are also used extensively by the artillery. Artillery FISTS all use systems based on laser emitters, either vehicle-mounted or lightweight, hand-carried units. This capability is also found in scout platoons with the GVS-5 laser range finder, and US Air Force and US Navy aircraft carry

laser target designators for aiming precision-guided munitions. Operators of laser firing devices receive extensive training in their safe employment. The devices themselves cannot be activated without deliberate action by the operator.

- (2) While the possibility of an accident is remote, it can happen. A victim might suddenly and unexpectedly move directly into the path of a laser beam and look directly at it, or a laser beam might reflect off a shiny surface and strike a victim in the eyes. To prevent such accidents, operators of laser firing devices must be kept constantly aware of friendly troop locations, and they must positively identify targets before lasing them. They should not fire lasers at reflective surfaces, and, whenever possible, they should give the oral warning, LASING, before activating the laser.
- (3) Conversely, commanders of soldiers operating in areas near friendly lasing must ensure that the commanders of laser-operating units are constantly aware of friendly troop locations. Soldiers should be alerted to the presence of friendly lasers in their areas and given the locations of the lasers if possible. They should be warned not to look in the direction of laser-emitting devices unless specifically told it is safe to do so. When possible, soldiers should wear the ballistic laser protection system (BLPS), which is available through normal supply channels.

WARNING

Using goggles to look through a magnifying optical device may not provide sufficient protection against lasers, depending on the intensity and frequency of the laser.

- d. **Tactical SOP.** The following is a tactical SOP for offensive and defensive operations with DEWs.
 - (1) **Offense.** Soldiers must be protected from the time they cross the LD/LC until combat is over, because they will not know the exact locations of laser range finders and laser designators. Therefore, leaders should—
 - (a) Mount and inspect all filters while in the *assembly area*. Leaders must inspect each soldier's laser goggles to ensure he has them and that they are serviceable. They must review the soldiers' knowledge of laser effects to ensure the soldiers will know when they have been engaged and can take appropriate counteraction. Leaders must also review soldiers' knowledge of the first-aid procedure for treating laser damage to eyes.
 - (b) While in the *attack position*, ensure that all soldiers wear their laser goggles and that gunners keep optical devices covered except during use.

- (c) Ensure that soldiers continue to wear their laser goggles, especially when using direct-view sights during the attack and consolidation.
- (2) **Defense.** A laser is the LOS device most likely to be used first by the enemy during a defensive operation to locate friendly positions. An enemy tank may use a laser on a suspected target before firing its main gun, or an enemy artillery observer may use the laser designator or range finder to control indirect-fire missions. These actions can hurt friendly equipment or soldiers. Therefore, leaders should—
 - (a) Ensure that when a vehicle or soldier moves from a hide position or from a covered and concealed position, all filters, electro-optical devices, and laser goggles are used.
 - (b) Ensure that soldiers open optical protective doors *only* during required observation or engagement of targets. Ensure soldiers use the naked eye to scan the battlefield until target cues such as movement or dust are observed, then use precision optics to identify and engage targets.
 - (c) Ensure that scouts and soldiers in observation posts wear laser goggles full-time, when the commander determines that the risk warrants doing so.
- e. **Soldier Preparation.** The main difference between being wounded by a laser weapon and being wounded by any other type of direct-fire weapon is the absence of noise and detectable signature from a laser weapon. Soldiers should be trained and educated accordingly. They must train using the laser protective equipment and techniques previously discussed. All soldiers should know how lasers affect them. (This information is contained in the laser survivability manual.) First-aid classes should be conducted to prepare soldiers to help DEW casualties. The battlefield is an unnatural and stressful environment where panic is always possible. This can be avoided through proper training, protective measures, and education.
 - (1) Soldiers most at risk from laser energy are those looking through devices with direct-view magnifying optics such as the TOW daysight or military binoculars. The laser energy that enters a direct-view optical device (DVOD) is increased by the square of the magnifying optic; the energy is further multiplied by the light transmission ability of the optic. Table D-1 lists examples of DVODs and electro-optical devices.
 - (2) Several methods can be used to protect against the possible effects of lasers directed against friendly soldiers. One way is to use nondirect-view optical devices such as thermal imagers or NVDs. The laser energy deposited on the screens of the imaging devices can burn out the devices themselves, but the eyes behind them are protected.
 - (3) Other protective measures are like those used against any LOS weapon. Cover and concealment should be used to avoid detection and possible lasing. Also, units should ensure that a minimum of optical surfaces are

presented to the enemy—for example, binoculars not in use should be pointed toward the ground or, if they are laid aside during combat, their lenses should be capped. Antitank and armor direct-view optical and electro-optical sighting devices should be covered when not in use.

- (4) Known and suspected locations of laser devices can be suppressed with artillery, mortars, or direct-fire weapons. Smoke can degrade the effectiveness of many types of lasers. When firing from a defensive position, soldiers should use alternate and supplementary positions to reduce the chance of being detected, suppressed, or destroyed by aimed fire.
- (5) Soldiers operating in an area where the enemy is known or suspected of using lasers should wear sun/wind/dust goggles with the laser filter attached. Commanders should realize that the BLPS filter does reduce contrast and available light for users. They can add a subparagraph to the “Coordinating Instructions” portion of OPORDs similar to that in the “Air Defense Warning Status” to provide soldiers with the best information available about enemy laser capabilities.
- (6) Soldiers should know of the potential hazard from laser devices. Laser range finders are the ones most likely to be used near friendly soldiers. US Air Force and US Navy aircraft may also carry laser target designators, used for aiming precision-guided munitions. To avoid injury to other friendly soldiers, operators of laser-firing devices must positively identify their targets before lasing. Also, lasers should never be fired at reflective surfaces.
- (7) Commanders must ensure that their subordinate units know the locations of any nearby friendly laser-operating units, and vice versa. Soldiers should be warned not to look in the direction of laser-emitting devices unless specifically told that doing so is safe. Each soldier should wear laser safety goggles matched to the wavelength of the friendly lasers.

Section II. TACTICAL IMPLICATIONS

The battalion task force must take precautions to protect itself in a DEW environment. It can do this by planning actions under a possible DEW attack and assuming an appropriate level of laser MOPP should such an attack occur.

D-4. PLANNING CONSIDERATIONS

The battalion task force conducts operations in a DEW environment by including the following in its planning

- a. The S2 identifies possible DEW threats during the IPB process and focuses reconnaissance assets to accurately identify and target those threats.
- b. The S3 incorporates the DEW threat into his operational plan—
 - (1) By integrating DEW countermeasures into the TF operation:
 - (a) Planning indirect suppressive fires on likely or suspected locations.
 - (b) Avoiding open terrain.
 - (c) Operating during conditions of poor visibility (fog, rain).
 - (d) Using obscurants.
 - (2) By advising the commander on the DEW protection level:
 - (a) Minimizing the number of personnel viewing through direct-view devices.
 - (b) Modifying vision blocks and other direct-view devices with tape or canvas to reduce personnel exposure (Figure D-1).
 - (c) Using eye protection equipment.

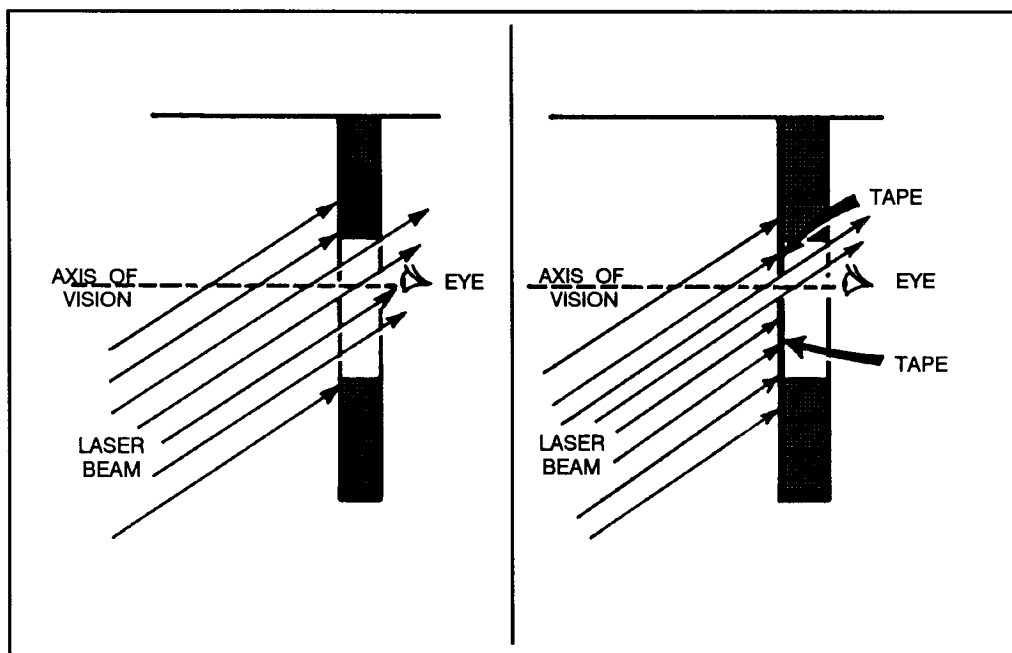

Figure D-1. Tape-on vision blocks.

- (3) By advising attached and OPCON elements of the threat.
- (4) By advising supporting Army aviation and Air Force personnel of the danger.

- c. To reduce the panic that may result from a DEW attack, leaders must ensure that their soldiers know—
- (1) Laser weapons can cause damage to the human eye ranging from temporary flash-blindness to permanent eye damage.
 - (2) Direct-view devices, optics, and especially magnifying devices, if attacked, pose the greatest danger to personnel (eye injury).
 - (3) Unless both eyes are being used in conjunction with an optical device, only one eye will be susceptible.
 - (4) Individuals might not immediately know the extent of damage, because the time that a person is flash-blinded by the brightness will vary among soldiers.
 - (5) Leaders and key system operators (gunners) are the most susceptible to DEW attack, because they are most likely to be looking out over the battlefield either with or without the aid of optics.

D-5. ACTIONS UNDER DIRECTED-ENERGY WEAPON ATTACK

When a unit comes under attack from DEW, it should—

- Advise higher headquarters of the attack.
- Increase the DEW protection level.
- Suppress the enemy systems.
- Employ obscurants.

D-6. TREATMENT OF LASER INJURIES

Laser eye injuries do not cause death. However, a laser injury can worsen with time, so soldiers with suspected laser injuries must be evaluated immediately and again at regular intervals. Most laser injuries can be treated in the unit or will heal by themselves.

- a. **Symptoms.** After receiving laser eye injuries, soldiers may experience sharp pain, a sudden loss of vision, streaky or spotty vision, or disorientation.
- b. **Corneal Burns.** Laser burns to the cornea (exterior surface of the eye) require eye ointment and an eye patch.
- c. **Retinal Burns.** Laser burns to the retina (interior surface of the eye) do not require an eye patch; in fact, an eye patch reduces the soldier's remaining vision. When internal hemorrhage is suspected, the injured soldier should be positioned with his head up to allow the blood to settle out of his center of vision.

- d. **Psychological Impact.** Because soldiers may not know the extent of their injuries, they are likely to experience shock. The psychological impact of a laser eye injury can be reduced by reassuring the injured soldier that the injury is not life threatening and that treatment is available, and evacuating him rapidly for further evaluation.
- e. **Evacuation.** Except when accompanied by shock or other injuries, laser eye injuries should be treated as routine for evacuation purposes. Sending the eye protection devices worn at the time of injury along with the injured soldier helps medical personnel identify the type of laser used and provides intelligence about threat capabilities (see FM 8-50 and FM 8-55).
 - (1) **Evacuate.** A high-energy laser pulse may severely burn or perforate the cornea. When this occurs, the eye should be protected from further injury—it should not be patched—and the injured soldier should be evacuated to a medical facility. Soldiers seeing large dark spots at or near the center of their vision or large floating objects, experiencing noticeable to severe vision impairment or an accumulation of blood in the eye *must be evacuated* for medical treatment.
 - (2) **Restrict duties, but do not evacuate.** Soldiers who experience little or no visual impairment but who are seeing dark spots in their fields of vision should be restricted to tasks they can perform effectively until they can again perform their normal duties.
 - (3) **Return to duty.** In the absence of other injuries, soldiers who are merely flash-blinded will recover in seconds.

D-7. LASER MISSION-ORIENTED PROTECTIVE POSTURE

The L-MOPP levels shown in Table D-2, page D-10, are based on threat activity and known use of lasers in the area of operations.

- a. The purpose of establishing MOPP levels for a laser threat is not to restrict a commander's actions but to standardize reporting language and an appropriate response. A commander who feels there is a potential laser threat to his soldiers, be it enemy or friendly, would obviously increase his level of responsiveness (understanding that there is the potential for accidental lasing of friendly soldiers from friendly weapons). The L-MOPP levels were intentionally not tied into the current NBC MOPP system. This was done to avoid confusion with an existing system of procedures and since the ballistic laser eye protection system may not be required with NBC protection. Reference to ballistic laser eye protection refers to the mounting of outserts on the mask when wearing NBC overgarments and masks.

MOPP LEVEL	LASER USE	ACTIVITY
L0	No known laser technology. No known use in area of operations. Use of laser technology highly unlikely.	Laser-protective eyewear in close proximity. Laser-protective eyewear properly prepared.
L1	Threat possesses laser technology. Laser-capable delivery systems spotted in area of operations. Use of laser capability possible.	Laser-protective eyewear carried on person and ready for use.
L2	Use of threat/friendly lasers reported in the area of operations. NBC-L reporting system in effect. Use of laser capability probable or highly likely.	Laser protection worn on face at all times.

Table D-2. L-MOPP levels.

b. The following reflects the addition of a laser-use reporting column to GTA 3-6-3 and inclusion of laser-use reporting. Alphabetical line codes at the left reflect line items for providing required information to higher headquarters and adjacent units.

(1) NBC 1 (observer's report).

LINE	LASER	REMARKS
B	Position of observer.	
C	Direction of attack from observer.	
D	Date-time group for detonation/attack.	
F	Location of area attacked.	
G	Means of delivery system.	State what weapon delivered the laser and what color the laser was, if known.
ZC	Area/point lasing.	State which was used, if known.

(2) NBC 3 Report (immediate warning of expected contamination-laser usage).

LINE	LASER	REMARKS
A	Strike serial number.	
D	Date-time group for start of attack.	
F	Location of probable area of attack.	

(3) NBC 6 Report (information on chemical, biological, or laser attacks).

LINE	LASER	REMARKS
A	Strike serial number.	
D	Date-time group for start of attack.	
F	Location of area attacked.	
G	Means of delivery system.	State what weapon delivered the laser and what color the laser was, if known.
I	Number of persons lased.	
M	Enemy action before and after attack; effect on troops.	
Y	Probable direction that attack is headed.	

* APPENDIX E

OPERATIONS IN NUCLEAR, BIOLOGICAL, AND CHEMICAL CONDITIONS

Chemical and biological agents and nuclear weapons may be employed separately or together and normally supplement conventional weapons. Planning must routinely address the use of each of these as well as protective measures against enemy NBC weapons.

CONTENTS	
PARAGRAPH	PAGE
Section I. NBC BATTLEFIELD	E-2
E-1 Function	E-2
E-2 Command	E-2
E-3 Staff	E-2
E-4 Effects of Nuclear Weapons	E-3
E-5 Protection	E-3
E-6 Radiological Monitoring	E-4
E-7 Radiological Survey	E-4
E-8 Operation Exposure Guide	E-5
E-9 Warning and Reporting System	E-5
Section II. CHEMICAL AND BIOLOGICAL DEFENSE	E-5
E-10 Characteristics	E-6
E-11 Defense Against Chemical Attack	E-6
E-12 Avoidance of Contamination	E-7
E-13 Defense Against Biological Attack	E-7
Section III. MISSION-ORIENTED PROTECTIVE POSTURE ..	E-8
E-14 Application	E-8
E-15 Mask Only	E-8
Section IV. DECONTAMINATION	E-9
E-16 Levels of Decontamination	E-9
E-17 Basic Skills Decontamination	E-10
E-18 Hasty Decontamination	E-10
E-19 Control Measures	E-10
Section V. RECONNAISSANCE	E-10
E-20 Employment	E-11
E-21 Organization	E-11
E-22 NBC Reconnaissance Systems	E-12

Section I. NBC BATTLEFIELD

The integration of NBC weapons as well as electronic warfare (EW) into tactical operations is described as the NBC-contaminated battlefield.

E-1. FUNCTION

The task force fights on the NBC-contaminated battlefield in essentially the same manner as on the conventional battlefield. However, combat service support and communications are disrupted more than on the conventional battlefield, and the task force and its units may be isolated or its movement restricted by nuclear, biological, or chemical contamination. Contamination avoidance is of paramount importance, but even contaminated units may have to fight. The larger force of which the task force is a part concentrates forces only when necessary to avoid creating a lucrative target. For the same reason, greater dispersion is required among task forces and their subordinate units. Tactics used on the conventional battlefield are especially suitable to the NBC-contaminated battlefield—full use of cover and concealment, overwatch, and suppression. However, in such an environment, the task force must be prepared to quickly implement unit protective measures to ensure its survivability. The task force may also be tasked to provide timely information to higher headquarters to assist employment of nuclear and chemical weapons in support of unit operations, or to exploit the effects of the use of these weapons. Operating effectively on the NBC-contaminated battlefield places additional responsibilities on all personnel within the battalion task force.

E-2. COMMAND

The task force commander prepares his units and personnel to operate in an NBC environment. To do this, he ensures that the task force takes the proper protective measures, including:

- Adequate dispersion and use of terrain shielding.
- Continuous NBC monitoring.
- Assuming the appropriate MOPP level.

E-3. STAFF

- a. For NBC operations, the task force chemical officer provides the technical advice to the task force commander and the remainder of the task force staff.
- b. Complete Decontamination (Deliberate). Complete decontamination is (deliberate) cleaning that reduces all or most of the contamination hazard to a level that permits removal of the protective mask and gloves. Residual

contamination may still remain after decontamination but not in sufficient amounts to warrant placing soldiers in full MOPP. To attain this goal, decontamination efforts must reduce residual contamination to negligible risk levels. Negligible risk levels are those that cause mild incapacitation among no more than 5 percent of unprotected soldiers who operate for 12 continuous hours within 1 meter of decontaminated surfaces.

E-4. EFFECTS OF NUCLEAR WEAPONS

- a. Nuclear weapons increase destructiveness on the battlefield compared to conventional weapons. Blast, nuclear, and thermal radiation effects are of primary concern.
- b. The electromagnetic pulse created in a nuclear burst can damage solid-state components and other electronic equipment, seriously interfering with command and control, communications, and target acquisition systems.
- c. Units should monitor radiation dosage levels to ensure soldiers are not exposed to dosage levels higher than the emergency risk factor. This is a radiation dose of more than 50 centigray (cGy). At this level, the commander can expect about 5 percent casualties. Because the body is weakened by radiation, soldiers should be allowed to rest.

E-5. PROTECTION

- a. The nuclear weapon, although a tremendously destructive device, is not one for which there is no defense. The more that soldiers know about the effects of nuclear weapons, the more effective they will be on the nuclear battlefield and the greater will be their chances for survival. Battlefield survival depends upon discipline, camouflage, cover, concealment, dispersion, and immediate reaction. A tank or deep fighting position with overhead cover provides the best protection from all nuclear weapons effects. Armor and mechanized infantry crews may have to operate on the nuclear battlefield with hatches closed.
- b. Operations on a nuclear battlefield require that soldiers take protective measures without receiving detailed directions. These measures include spreading the alert, taking advantage of natural shielding such as valleys and reverse slopes, positioning thickest vehicle armor toward the blast, locking turrets and brakes, removing antennas and vision blocks, removing flammable materials (including camouflage), securing equipment and ammunition, and disconnecting radio frequency (RF) cables. Unit SOPs must include actions to be taken during and after both friendly and enemy employment of nuclear weapons.

E-6. RADIOLOGICAL MONITORING

- a. Radiological monitoring is the detection of radiation and the measurement of dose rate with radiac instruments. Radiological monitoring of the unit area alerts the commander to a hazard that otherwise would go undetected and unmeasured.
- b. A single radiation measurement usually has a limited operational significance (except to the unit in the immediate area), since it gives information at the point of the reading only. However, a number of individual measurements considered together can give a picture of the radiation pattern over an area. A number of readings made at the same points over a period are required in uneven terrain.
- c. Monitoring is included in the normal reconnaissance and intelligence activities of all units. Radiological monitoring at all levels is a command responsibility. It is initiated upon order of the unit commander or higher headquarters, or pursuant to SOPs. Units that detect radiation in an area report it according to their SOP and mark the area with a radiological contamination marker. Radiation dosages and times and location of readings are reported to higher headquarters.
- d. Monitoring techniques, correlation factor data, and recording forms are described in FM 3-3. Monitoring may be periodic or continuous:
 - (1) Periodic monitoring is conducted during nuclear warfare. All units routinely (at least once an hour) monitor a designated point in their respective areas. The NBC defense annex of the unit SOP must give detailed guidance on monitoring procedures.
 - (2) Continuous monitoring is initiated by all units when a fallout warning is received; when a unit is on an administrative or tactical move; when a nuclear burst occurs; when radiation above 1 cGy per hour is detected by periodic monitoring and on order of the commander. Continuous monitoring stops upon instructions from the commander or higher headquarters, or when the dose rate falls below 1 cGy per hour (except for units on the move),

E-7. RADIOLOGICAL SURVEY

The radiological survey is a directed effort to determine the degree and extent of radiological contamination in a specific area. FM 3-3 provides detailed guidance for radiological surveys. Surveys are performed by one or more radiological survey parties and a control party. A ground survey party includes a monitor who operates a dose-rate meter and records all survey data, and an assistant who may be a driver, radio operator, or both. Additional personnel may be included in the party for security or other reasons. An aerial survey party consists of a monitor, whose duties are similar to those of the ground monitor, and a pilot or aircrew. The control party directs the survey, collects the data reported, and

assembles the data into a usable form. The control party organization varies, depending on the level of command that it serves. The control party and the survey parties are usually organized and equipped from unit resources as follows:

- a. **Companies.** Companies train one primary and one alternate operator for each dose-rate survey meter in the unit.
- b. **Task Forces.** Battalion commanders equip and organize a control party capable of planning and directing decentralized survey operations.

E-8. OPERATION EXPOSURE GUIDE

Operations in a nuclear environment are complicated by the necessity to control exposure of personnel to nuclear radiation. AN OEG is a method of determining the maximum radiation dose to which units may be exposed and still accomplish a mission. Determination of this dose is based on the accumulated dose or radiation history of the unit. The OEG requires that radiation exposure records be maintained on all units within the task force. The most realistic data can be obtained from readings at the platoon level.

E-9. WARNING AND REPORTING SYSTEM

The primary means of warning units of an actual or predicted NBC hazard is the NBC warning and reporting system. It is a key in minimizing the effects of NBC attacks.

- a. The system consists of six reports:
 - NBC 1 — Observer's initial report giving basic data.
 - NBC 2 — Evaluated data report.
 - NBC 3 — Warning of predicted contamination report.
 - NBC 4 — Monitoring and survey report.
 - NBC 5 — Actual contaminated areas report.
 - NBC 6 — Detailed information on chemical or biological attack.
- b. Each report is used for a specific purpose and uses standard codes to simplify the message. Specific instructions for acquiring the information and sending the reports are discussed in FM 3-3.

Section II. CHEMICAL AND BIOLOGICAL DEFENSE

It is the policy of the United States not to use toxic chemical weapons first. However, they may be used in retaliation if an enemy employs them against

United States forces. The United States policy is not to use biological weapons under any circumstances. Countries that once made up the former Soviet forces have both chemical and biological weapons, and may use them. The battalion task force should expect to fight in an active chemical and biological environment. These weapons may be used separately, simultaneously with conventional weapons, or in combination with conventional and nuclear weapons.

E-10. CHARACTERISTICS

- a. Chemical agents are used to degrade battlefield performance, restrict the use of terrain, incapacitate, and kill. Agents such as an air-contaminating agent (aerosol) or ground-contaminating agent (liquid) may be placed on a target. A mixture of agents can be used to increase confusion and casualties. (See FM 3-6 and FM 3-9.)
- b. Biological agents are disease-producing microorganisms (germs) or their poisonous by-products (toxins), which can cause injuries, death, disease, and deterioration of material. The intentional use of microorganisms creates a disease hazard where none exists naturally. These biological agents may be dispersed as aerosols by generators, explosives, bomblets, missiles, and aircraft. Harmful microorganisms may also be spread by the release of vectors such as flies, mosquitos, fleas, and ticks.

E-11. DEFENSE AGAINST CHEMICAL ATTACK

- a. Protective measures taken by units when operating under the threat of chemical attack or in a chemical environment are governed by the nature of the threat, the mission, the situation, and the weather. The primary consideration in chemical warfare is to avoid contamination. Under threat of chemical attack, soldiers should employ all measures to protect themselves from contamination. However, once troops are contaminated, the task force commander must employ techniques that ensure their survival and the sustainment of the battle.
- b. Maneuver of troops and supplies should be planned so that contaminated terrain is avoided, consistent with security and the mission. Contaminated terrain is crossed only when necessary and then as quickly as possible, preferably in vehicles at speeds and intervals that minimize contamination of following vehicles. Decontaminating materials and sufficient time for decontamination must be made available after the area has been crossed. Heavy work by personnel dressed in chemical protective clothing and equipment is planned for the coolest part of the day, if the situation and mission permit. When positions are occupied, the area should be so organized that alternative uncontaminated positions can be occupied quickly if required. Individual soldiers must be thoroughly trained in the use of individual protective measures.

E-12. AVOIDANCE OF CONTAMINATION

Fundamental to the avoidance of contamination is the detection and identification of chemical hazards.

a. **Detection and Identification.**

(1) Detection measures include use of chemical-agent alarms and chemical detection kits. Reconnaissance missions include NBC detection capability to—

- Provide early warning of contamination.
- Determine the extent of contamination.
- Find clear routes through or around contamination.

(2) Once a hazard has been detected, the next step is to identify it.

(3) When contamination is found, it must be marked.

b. **Actions Before Chemical Attack.** The commander designates a level of MOPP for the unit. He bases his decision on an analysis of the situation in which he balances his mission requirements against the chemical protection requirements and other factors. MOPP is discussed in detail in FM 3-4.

E-13. DEFENSE AGAINST BIOLOGICAL ATTACK

Defense against a biological attack is keyed on recognition of a biological threat, preventive measures that can be taken by friendly units, and prompt evacuation or isolation of casualties.

a. **Recognition.** Although biological attacks are difficult to detect, alert personnel can recognize indications that a biological agent may have been employed through—

- Evidence of delivery mechanisms (for example, aircraft spray, liquids, bombs).
- Outbreak of a disease not common to the area.
- Increased reports of sickness.
- Dead or sick animals in the area.

b. **Preventive Measures.** Preventive measures to reduce casualties from biological attack include—

- Maintaining high standards of personal hygiene.
- Avoiding practices that may produce extreme fatigue.
- Ensuring adherence to high standards of field sanitation.
- Providing immunization from known or suspected enemy biological agents.
- Providing instruction in proper care of cuts and wounds.
- Using only approved sources of food and water.

- Ensuring that rodents and other pests are controlled.
 - Quarantining contaminated areas.
- c. **Casualties.** Personnel who become ill because of a biological attack are processed the same as for illness resulting from normally transmitted diseases. Those patients affected by a contagious biological agent may require isolation to ensure contamination control on the NBC-contaminated battlefield.

Section III. MISSION-ORIENTED PROTECTIVE POSTURE

MOPP is a flexible system of protection used in chemical warfare. It requires the soldier to wear individual protective equipment consistent with the chemical threat, the work rate imposed by the mission, and the temperature. Individual protective clothing becomes standard combat dress when directed by the theater commander.

MOPP does not mean that soldiers must wear all of their protective equipment all of the time. In fact, because of duty requirements, body heat buildup, and basic human needs, they cannot wear it for an indefinite period. It does, however, give the commander and staff a range of choices of chemical protection for their units. For further details concerning individual and collective protection, see FM 3-4.

Mission accomplishment is never compromised for protection.

E-14. APPLICATION

All combat operations are conducted under the MOPP system. There are five levels of MOPP a commander may designate (Figure E-1).

E-15. MASK ONLY

In a contaminated environment in which no blister agent vapors are present, soldiers do not need to wear protective overgarments or rubber gloves as long as they are protected from direct skin exposure to liquid or solid contamination. Tanks, some kinds of vans, and buildings are examples of shelters that provide partial protection from contamination. Inside these shelters, soldiers are normally exposed to vapor hazards but not to direct exposure.

MOPP LEVEL	OVER-GARMENT	OVER-BOOTS	MASK/HOOD	GLOVES
0	Available	Available	Carried	Available
1	Worn, open or closed based on temperature	Carried	Carried	Carried
2	Same as MOPP1	Worn	Carried	Carried
3	Same as MOPP1	Worn	Worn, hood opened or closed, based on temperature	Carried
4	Worn, closed	Worn	Worn, closed	Worn

Figure E-1. Levels of MOPP.

Section IV. DECONTAMINATION

The more decontamination the unit does, the more expensive it is in resources—manpower, time, and materials. The wisest way to conserve those resources and still sustain combat potential is by applying the following four principles:

- Decontaminate as soon as possible.
- Decontaminate only what is necessary.
- Decontaminate as far forward as possible.
- Decontaminate by priority.

E-16. LEVELS OF DECONTAMINATION

- a. **Partial Decontamination (Basic Skills and Hasty).** Partial decontamination includes any technique that removes or neutralizes all visible or detectable contamination from exposed portions of the skin, individual clothing, and equipment and from those surfaces of equipment that operators or crew must touch to perform their mission. Partial decontamination is the complete decontamination of a small area on a piece of equipment.
- b. **Complete Decontamination (Deliberate).** Complete decontamination is (deliberate) cleaning that reduces all or most of the contamination hazard to a level that permits removal of the protective mask and gloves. Residual contamination may still remain after decontamination, but not in sufficient amounts to warrant placing soldiers in full MOPP. To attain this goal, decontamination efforts must reduce residual contamination to negligible levels. Negligible risk levels are those that cause mild incapacitation among no more than 5 percent of unprotected soldiers who operate for 12 continuous hours within 1 meter of decontaminated surfaces.

E-17. BASIC SKILLS DECONTAMINATION

Soldiers use these techniques to survive and continue to fight on the NBC-contaminated battlefield. The soldiers are trained to decontaminate themselves and their equipment automatically after being contaminated.

- Skin decontamination.
- Personal wipedown.
- Operator's spraydown.

E-18. HASTY DECONTAMINATION

Hasty decontamination (which includes the actions of teams, squads, and platoons) reduces performance degradation in three ways. It reduces the spread of contamination on people and equipment that can allow temporary relief from MOPP4; it speeds the weathering process for chemical and biological contamination, which can lead to the complete decontamination objective; and it may reduce radiological contamination significantly, in turn reducing radiation hazards to unprotected soldiers to a negligible risk.

E-19. CONTROL MEASURES

The following control measures are used for decontamination operations:

- Coordination point.
- Route.
- Task force assembly area.
- Unit decontamination position.
- Ready line.
- Dismount point.
- Decontamination site.
- Route to company holding area.
- Company holding area.
- Driver's route to dismount point.

Section V. RECONNAISSANCE

During mechanized infantry or armored combat operations, NBC reconnaissance platoons or sections operate throughout the battlefield. In the forward combat area, commanders integrate all of these into the overall reconnaissance and surveillance effort to determine whether specified areas are

contaminated. Commanders use this information along with their IPB to manage the battlefield. Contamination avoidance procedures are discussed in greater detail in FM 3-3.

E-20. EMPLOYMENT

NBC reconnaissance platoons or sections perform five critical tasks on the battlefield, and must do so quickly.

- a. **Detect Contamination.** NBC reconnaissance platoons or sections must detect hazards early so those in affected areas can be warned.
- b. **Identify Contamination.** NBC reconnaissance platoons or sections must identify the type of contamination so preventive measures can be taken and casualties treated.
- c. **Mark Contaminated Area.** Contaminated areas must be marked so friendly forces can avoid them.
- d. **Report.** Contamination data must reach commanders or leaders so they can respond.
- e. **Sample.** To ensure proper identification of contaminating agents, the NBC reconnaissance platoon or section returns samples for laboratory analysis.

E-21. ORGANIZATION

The NBC reconnaissance platoon in a mechanized infantry or armored division consists of 1 officer and 19 enlisted soldiers. It is equipped with six M93 NBC Reconnaissance System (NBCRS) vehicles or M113A2 APCs. Each platoon consists of three squads. Each squad consists of two teams; each team has one vehicle (Figure E-2). The platoon leader and sergeant ride in two of the vehicles to control the platoon.

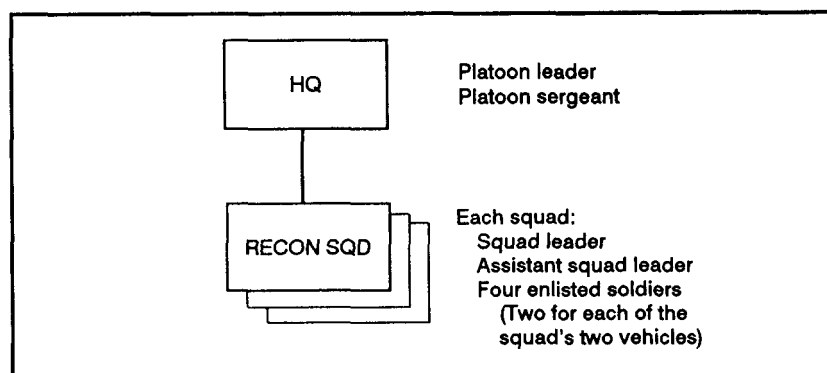

Figure E-2. Organization of an NBC platoon in a mechanized infantry or armored division.

E-22. NBC RECONNAISSANCE SYSTEMS

Using NBC reconnaissance systems (vehicles) allows the commander to obtain accurate, timely reports of the condition of the battlefield. Commanders must therefore know how to employ these systems within the bounds of their limitations and capabilities.

- a. **M93 NBCRS-Equipped.** The M93 NBCRS, also known as the Fox NBC system, is a lightly armored wheeled vehicle with on-board chemical detection equipment.
 - (1) **Capabilities.** The NBCRS can monitor the environment while moving and, depending on terrain, can usually move as quickly as maneuver forces. The vehicle's built-in positioning system simplifies navigation and increases the accuracy of its reports of contaminated areas. The crew operates from inside the vehicle. An overpressure system allows the crew to work without masks in contaminated areas, increasing their effectiveness. The on-board detection apparatus identifies all known chemical warfare agents. It can also store new data on unknown chemical agents.
 - (2) **Limitations.** Calibrating the detection instruments and repairing the vehicular components of the NBCRS requires special maintenance and support. Before a mission, the system's on-board chemical detection apparatus requires 20 to 30 minutes of preparation. However, the greatest limitation of the NBCRS is that soldiers do not easily recognize it as friendly.
- b. **M113 APC-Equipped or HMMWV-Equipped.** NBC reconnaissance platoons may use these vehicles instead of or along with the M93 NBCRS.
 - (1) **Capabilities.** Parts for the M113 APC and the HMMWV are readily available, and soldiers can easily recognize both vehicles as friendly. Their large sizes enable them to carry a lot of contaminated material, and they have larger weapon systems for their own protection (each has a .50 caliber heavy barrel machine gun). On rough terrain, these vehicles can keep up with maneuver forces.
 - (2) **Limitations.** If the maneuver forces are equipped with M1 tanks or BFVs, the M113 APCs and HMMWVs, which cannot move as quickly on flat, open terrain, will slow them down. Also, because these vehicles lack overpressure systems, their crews must wear MOPP4 clothing. Finally, neither vehicle has on-board detection equipment, so the soldiers must stop and exit the vehicle and must collect the information manually using less reliable and less complete means (either chemical agent monitors—CAMs—or M256A1 paper).

* APPENDIX F

SNIPER EMPLOYMENT

Snipers play an important role in the mechanized infantry battalion. They give the commander accurate, discriminatory, long-range, small-arms fire. These tires are best used against key targets that, due to their range, size, location, visibility, security and stealth requirements, collateral damage, intensity of conflict, or rules of engagement, cannot be destroyed by other available weapon systems. Also, the individual techniques snipers use enable them to gather detailed, critical information about the enemy, though this is a secondary role. The effectiveness of a sniper is measured by more than casualties or destroyed targets. Commanders know that snipers also affect enemy activities, morale, and decisions. Knowing snipers are present hinders the enemy's movement, creates confusion and continuous personal fear, disrupts enemy operations and preparations, and compels the enemy to divert forces to deal with the snipers. (See FM 23-14.)

CONTENTS	
PARAGRAPH	PAGE
F-1 Sniper Teams	F-1
F-2 Offensive Employment	F-4
F-3 Actions Against Fortified Areas	F-6
F-4 Defensive Employment	F-7
F-5 Retrograde Employment	F-8
F-6 MOUT Employment	F-9
F-7 River Crossings	F-11
F-8 Patrolling	F-12

F-1. SNIPER TEAMS

Snipers are employed in two-man teams; each team consists of one sniper and one observer, normally cross-trained. The observer carries an M16-series rifle, the sniper carries the sniper weapon system, and each has a side arm. Snipers should avoid sustained battles. During long periods of observation, team members help each other with range estimation, round adjustment, and security.

- a. Sniper teams should be centrally controlled by the commander or designated sniper employment officer. Once they are deployed, snipers must be able to operate independently, as required. Therefore, they must understand the commander's intent, his concept of the operation, and the purpose for their assigned tasks. This allows them to exercise initiative within the framework of the commander's intent and to support the commander's concept and

achievement of the unit's mission. To ensure clear fields of fire and observation, the teams must be able to choose their own positions once they are on the ground. Snipers are effective only in areas that offer good fields of fire and observation. The number of sniper teams participating in an operation depends on their availability, the expected duration of the mission, and enemy strength.

- b. Sniper teams should move with a security element (squad/platoon) when possible. This allows the teams to reach their areas of operation faster and safer than if they operated alone. The security element also protects the snipers during operations. When moving with a security element, snipers follow these guidelines:
 - (1) The leader of the security element leads the sniper team.
 - (2) Snipers must appear to be an integral part of the security element. To do so, each sniper carries his weapon system in line with and close to his body to hide the weapon's outline and barrel length. Sniper-unique equipment (optics, ghillie suit) is also concealed from view.
 - (3) The uniform must be the same as that of element members, and proper intervals and positions in the element formation are maintained.
- c. History has proven that commanders must be educated as to the proper use of a sniper. If commanders know the abilities and limitations of a sniper, the sniper can contribute significantly to the fight. Commanders should consider carefully all the factors of METT-T when conducting their estimate of the situation.
 - (1) **Mission.** The sniper's primary mission is to support combat operations by delivering precise rifle fire from concealed positions. The mission assigned to a sniper team for a particular operation consists of the task(s) the commander wants the sniper team to accomplish and the reason (purpose) for it. The commander must decide how he wants his sniper team to affect the battlefield. Then he must assign missions to achieve this effect. The commander should prioritize targets so snipers can avoid involvement in sustained engagements. Regardless of the method used, the sniper team must be free to change targets to support the commander's intent.
 - (a) The commander may describe the effect or result he expects and allow the sniper team to select key targets.
 - (b) The commander may assign specific *types* of targets—for example, if he wants to disrupt the defensive preparations of the enemy, he may task snipers to kill operators of bulldozers and other engineer equipment. He may task them to disable enemy vehicles carrying supplies. Or, he may task them to engage soldiers digging enemy defensive positions.
 - (c) The commander may also assign specific targets. These can include enemy leaders, command and control operators, ATGM gunners,

armored-vehicle commanders, or weapons crews. In cases where large crowds pose a threat to US forces, snipers can single out selected individuals. In populated areas where casualties should be kept low, the snipers can be assigned to kill enemy snipers.

- (2) **Enemy.** The commander must consider the characteristics, capabilities, strengths, weaknesses, and disposition of the enemy. Is the enemy force heavy or light, rested or tired, disciplined or not? Is it motorized infantry or towed artillery? Is it well-supplied or short of supplies? Is it patrolling aggressively or is it lax in security? Is it positioned in assembly areas or dug in? The answers to such questions help the commander determine the enemy's susceptibility and reaction to effective sniper operations. Naturally, a well-rested, well-led, well-supplied, and aggressive enemy with armored protection poses a greater threat to snipers than one who is tired, poorly led, poorly supplied, lax, and unprotected. Also, the commander needs to know if enemy snipers are present and if they are effective; they can pose a significant danger to his own snipers. Also, the enemy's DEW capability should be considered. Snipers use optical devices, so they are particularly vulnerable to this threat.
- (3) **Terrain.** The terrain in the sniper's area of operations and the terrain he must travel to reach it must be evaluated. The commander must consider the time and effort snipers will expend getting into position. He must also consider the effect of weather on the sniper and on his visibility. Snipers need good firing positions. They prefer positions at least 300 meters from their target area. Operating at this distance allows them to avoid effective fire from enemy rifles, yet they retain much of the 800-meter to 1,000-meter effective range of the sniper rifle. To be most effective, snipers need areas of operations with adequate observation and fields of fire.
- (4) **Troops.** The commander must decide how many sniper teams to use. This depends on their availability, on the duration of the operation, on the expected opposition, and on the number and difficulty of tasks, targets, or both assigned to snipers. The snipers' level of training and physical condition must also be considered. Commanders must remember the effect of these human factors on sniper operations.
- (5) **Time available.** The commander must consider how long the snipers will have to achieve the result he expects. He must allocate time for snipers to plan, coordinate, prepare, rehearse, move, and then to establish positions. The commander must understand how the snipers' risk increases when they lack adequate time to plan or to do things such as move to the area of operations. The amount of time a sniper team can remain in a position without loss of effectiveness due to eye fatigue, muscle strain, or cramps, depends mostly on the type of position he is occupying. Generally, snipers can remain in an expedient position for 6 hours before they must be relieved. They can remain in belly positions or semipermanent hides for up to 48 hours before they must be relieved.

Mission duration times average 24 hours. (FM 23-10 provides guidance on sniper position considerations, construction, and preparation and occupation times.) Movement factors for snipers moving with a security element are the same as for any infantry force. When snipers are moving alone in the area of operations, they move slowly; their movement can be measured in feet and inches. The sniper team is best qualified to determine how much time is required for a particular movement.

F-2. OFFENSIVE EMPLOYMENT

Offensive operations carry the fight to the enemy to destroy his capability and will to fight. By killing enemy targets that threaten the success of the attack, the sniper can play a major role in offensive operations.

- a. During offensive operations, snipers—
 - (1) Conduct countersniper operations.
 - (2) Overwatch movement of friendly forces and suppress enemy targets that threaten the moving forces.
 - (3) Place precision fire on enemy crew-served weapons teams and into exposed apertures of bunkers.
 - (4) Place precision fire on enemy leaders, armored-vehicle drivers or commanders, FOs, or other designated personnel.
 - (5) Place precision fire on small, isolated, bypassed forces.
 - (6) Place precision fire on targets threatening a counterattack or fleeing.
 - (7) Assist in screening a flank using supplemental fires.
 - (8) Dominate key terrain by controlling access with fires.
- b. During a movement to contact, snipers move with the lead element, or they can be employed 24 to 48 hours before the unit's movement—
 - (1) To select positions.
 - (2) To gather information about the enemy.
 - (3) To dominate key terrain, preventing enemy surprise attacks.
- c. During a mounted attack, the sniper's role is limited by fast movement. However, snipers can provide effective support during a dismounted assault.
 - (1) Contact may force the mounted element to dismount and continue moving dismounted. Snipers placed with lead elements move to positions that allow them to overwatch the dismounted movement of the element and to provide long-range small arms fire. Sniper teams are most effective where BFVs are ineffective—that is, where BFVs cannot provide overwatching fires for any reason. For example, in certain areas, the terrain may limit BFV mobility. In other areas, the enemy situation may present an unacceptable risk to BFVs occupying hull defilade positions.

BFV movement could compromise the stealth of the dismounted force. Multiple avenues must be overmatched.

- (2) Snipers may also be placed with a mounted support element assigned to suppress, fix, or isolate the enemy on the objective. The sniper rifle's precision fire and lack of blast effect allow the sniper to provide closer supporting fires for assaulting soldiers than the mounted support element can provide. This difference in their weapons' effective ranges requires the snipers and the mounted support element to seek support-by-fire positions at different ranges, when terrain allows. Long after BFVs and tanks are forced to shift or lift their supporting fires, snipers can selectively fire on close-in targets that are threatening the assault. These targets may be gunners of enemy crew-served weapons or enemy soldiers in fortified positions. Snipers always aim carefully to avoid possible fratricide due to ricochets.
- (3) If time permits, snipers may be deployed as soon as the element reaches the dismount point. The snipers' weapons have better optics and longer ranges than other types of small arms. This is why snipers are assigned to provide additional long-range observation and precision fire on any enemy targets that may appear. To increase security, snipers may cover different sectors than the mounted elements.
- (4) Snipers may move with the dismounted element toward the objective. The snipers may then occupy a close-in support-by-fire position, where they can help suppress or destroy targets threatening the assault of the dismounted element. Or they may move along with the dismounted element onto the objective to provide close-in precision fire against enemy fortified positions, bunkers, and trenchlines. Selection of the sniper support-by-fire position is dependent on METT-T. Obviously, the closer snipers are to the objective area, the greater the chance they will be discovered and lose their effectiveness.
- (5) To increase security and surprise, snipers may move covertly into position in an objective area, well before the main attack and mounted forces arrive. If mounted elements appear on the battlefield at the same time the snipers arrive, the snipers' security and potential for surprise are both degraded. Ideally, a sniper team going in early moves with infiltrating dismounted infantry. This is faster and more secure than moving alone. After the snipers are in position, the dismounted infantry may remain nearby as additional security, but they are more likely to have other supporting tasks to perform. However, even the proximity of dismounted infantry enhances security.
- (6) After their fires are masked, snipers must reposition as soon possible. The speed of mechanized assaults may prevent snipers from firing from more than one support position. For this reason, the commander must carefully evaluate where the snipers will be most useful. If he wants to use snipers in several different places, or if he wants them to contribute

- throughout the attack, he should provide transportation to enable them to move quickly, stealthily, and safely about the battlefield.
- (7) Upon consolidation, snipers may displace forward to new positions. These positions may not necessarily be on the objective. From these positions, the snipers provide precision fire against bypassed enemy positions, enemy counterattack forces, or other enemy positions that could degrade the unit's ability to exploit the success of the attack.
 - d. During a raid, sniper teams can be employed with either the security element or the support element—
 - (1) To cover avenues of approach and escape that lead in and out of the objective.
 - (2) To cover friendly routes of withdrawal to the rally point.
 - (3) To provide long-range fires on the objective.
 - e. After consolidation, snipers may displace forward to new positions, not necessarily on the objective, where they can place precision fire on bypassed enemy positions, enemy counterattack forces, or other enemy positions that could degrade the unit's ability to exploit the success of the attack.

F-3. ACTIONS AGAINST FORTIFIED AREAS

Assaulting forces invariably encounter some type of fortified positions prepared by the defending force. These can range from field-expedient, hasty positions produced with locally available materials, to elaborate steel and concrete emplacements complete with turrets, underground tunnels, and crew quarters. Field-expedient positions are those most often encountered. However, elaborate positions should be expected when the enemy has had significant time to prepare his defense. He may have fortified weapons emplacements or bunkers, protected shelters, reinforced natural or constructed caves, entrenchments, and other obstacles.

- a. The enemy will try to locate these positions so they are mutually supporting and are arrayed in depth across the width of his sector. He will also try to increase his advantages by covering and concealing positions and by preparing fire plans and counterattack contingencies. Because of this, fortified areas should be bypassed and contained by a small force.
- b. The sniper's precision-fire and observation capabilities are invaluable in the assault of a fortified area. Pinpoint targets invisible to the naked eye are readily detected and are destroyed by precision rifle fire. The snipers' role during the assault of a fortified position is to deliver precision fire against the embrasures, air vents, and doorways of key enemy positions; observation posts; and exposed personnel. The commander must plan the order in which sniper targets should be destroyed. Their destruction should systematically reduce the enemy's defense by destroying the ability of enemy positions to support each other. Once these positions are isolated, they can be more

easily reduced. Therefore, the commander must decide where he will try to penetrate the enemy's fortified positions, then he must employ his snipers against those locations. Snipers can provide continuous tire support for both assaulting units and other nearby units when operating from positions near the breach point on the flanks. Sniper fires add to the effectiveness of the entire unit; the commander can employ snipers in situations where other resources cannot be used for various reasons.

- c. The sniper team bases their plan on information available. The enemy information they need includes the following:
 - (1) Extent of and exact locations of individual and underground fortifications.
 - (2) Fields of fire, directions of fire, locations and number of embrasures, and types of weapons systems in the fortifications.
 - (3) Locations of entrances, exits, and air vents in each emplacement.
 - (4) Locations and types of existing and reinforcing obstacles.
 - (5) Locations of weak spots in the enemy's defense.

F-4. DEFENSIVE EMPLOYMENT

Snipers may effectively enhance or augment any unit's defensive fire plan. After analyzing the terrain, the sniper team should recommend options to the commander.

- a. The sniper team can perform the following tasks during defensive operations:
 - Cover obstacles, minefields, roadblocks, and demolitions.
 - Perform counterreconnaissance (kill enemy reconnaissance elements).
 - Engage enemy OPs, armored-vehicle commanders exposed in turrets, and ATGM teams.
 - Damage enemy vehicles' optics to degrade his movement.
 - Suppress enemy crew-served weapons.
 - Disrupt follow-on units with long-range small-arms fire.
- b. Snipers are generally positioned to observe or control one or more avenues of approach into the defensive position. Due to the types of weapons systems available, snipers may be used against secondary avenues of approach. Snipers can be used to increase all-round security and to allow the commander to concentrate his combat power against the most likely enemy avenue of approach. Snipers may support the battalion by providing extra optics for target-acquisition and precise long-range fires to complement those of the M249, M60, and M2 machine guns. This arrangement seeks to maximize the effectiveness of all the unit's weapon systems. Snipers may be used in an economy-of-force role to cover a dismounted enemy avenue of approach into positions the battalion cannot cover.

- c. Snipers establish alternate and supplementary positions for all-round security. Positions near the FEBA are vulnerable to concentrated attacks, enemy artillery, and obscurants. Multiple teams, if used, can be positioned for surveillance and mutual fire support. If possible, they should establish positions in depth for continuous support during the fight. The sniper's rate of fire neither increases nor decreases as the enemy approaches. Specific targets are systematically and deliberately shot; accuracy is not sacrificed for speed.
- d. Snipers can be placed to overwatch key obstacles or terrain such as river-crossing sites, bridges, minefields that canalize the enemy directly into engagement areas, and so on. Snipers are mainly used where weapons systems are less effective due to security requirements or terrain. Even though weapons systems with greater range and optics capability than the snipers' weapons are available to the commander, he may be unable to use them for any of several reasons. They might present too large a firing signature, be difficult to conceal well, create too much noise, or be needed more in other areas. Sniper team members provide the commander with better observation and greater killing ranges than do other soldiers.
- e. Snipers can be used as an integral part of the counterreconnaissance effort. They can help acquire or destroy targets, or both. They can augment the counterreconnaissance element by occupying concealed positions for long periods. They can also observe, direct indirect fires (to maintain their security), and engage targets. Selective long-range sniper fires are difficult for the enemy to detect. A few well-placed shots can disrupt enemy reconnaissance efforts, force him to deploy into combat formations, and deceive him as to the location of the main battle area. The sniper's stealth skills counter the skills of enemy reconnaissance elements. Snipers can be used where scout or rifle platoon mobility is unnecessary, freeing the scouts and riflemen to cover other sectors. Snipers can also be used to direct ground maneuver elements toward detected targets. This also helps maintain their security so they can be used against successive echelons of attacking enemy.
- f. Snipers should be tasked to support any unit defending a strongpoint. The characteristics of the sniper team enable it to adapt to performing independent harassing and observation tasks in support of the force in the strongpoint, either from within or outside of the strongpoint.
- g. Snipers can provide effective long-range fires from positions forward of the topographical crest or, if the unit is occupying a reverse-slope defense, on the counterslope.

F-5. RETROGRADE EMPLOYMENT

The sniper team must know the concept, intent, and scheme of maneuver. Withdrawal times, conditions, or both; priorities for withdrawals; routes;

support positions; rally points; and locations of obstacles are all key information the sniper must know. Both engagement and disengagement criteria must be planned and coordinated to ensure snipers achieve the desired effect without compromising their positions. (Chapter 5 discusses retrograde operations.)

- a. Snipers can help the delaying force cause the enemy to deploy prematurely during retrograde operations. They help by inflicting casualties with accurate, long-range, small-arms fire. When the enemy receives effective small-arms fire from unknown positions, he is likely to assume he is near an enemy position (most likely one with ATGMs) and he will begin to maneuver to a position of advantage against the perceived threat. Thus, using a sniper team, the commander can achieve the same effect that he could with another infantry unit. The snipers' stealth also gives them a better chance of infiltrating out of positions close to the enemy.
- b. Delaying forces risk being bypassed or overtaken by attacking enemy forces during retrograde operations. Commanders may provide transportation to move snipers to successive positions. Vehicles must remain in defilade positions to the rear of the sniper position; or, they must occupy different positions away from the sniper's area of operations so as not to compromise the sniper's position. In either case, a linkup point, egress routes, and conditions for executing the linkup must be fully coordinated. Commanders may also provide communications assets to the sniper team to facilitate control and movement.
- c. Snipers, as well as other units, may find themselves behind the enemy's front; therefore, they must be prepared to infiltrate back to friendly positions. Their infiltration plans must be fully coordinated to avoid fratricide when they try to reenter a friendly position. When planning successive positions, the commander must realize that the sniper team may be unavailable for use if they are destroyed or are having difficulty disengaging from an enemy force. In view of this, the commander must consider carefully how and where he wants snipers to contribute to the operation. Planning too many positions for the sniper team in a fast-paced retrograde is sure to result in failure.
- d. Snipers may be assigned any of the following specific tasks:
 - Delay the enemy by inflicting casualties.
 - Observe avenues of approach.
 - Cover key obstacles with precision fire.
 - Direct artillery fire against large enemy formations.

F-6. MOUT EMPLOYMENT

The value of the sniper to a unit operating in an urban area depends on several factors. These factors include the type of operation, the level of conflict, and the rules of engagement. Where ROE allow destruction, the snipers may not be needed since other weapons systems available to a mechanized force have

greater destructive effect. However, they can contribute to the fight. Where the ROE prohibit collateral damage, snipers may be the most valuable tool the commander has.

- a. Sniper effectiveness depends in part on the terrain. Control is degraded by the characteristics of an urban area. To provide timely and effective support, the sniper must have a clear picture of the scheme of maneuver and commander's intent.
 - (1) Observation and fields of fire are clearly defined by roadways, but surveillance is limited by rooftops, windows, and doorways; each of these require constant observation. Also, the effects of smoke from military obscurants and burning buildings can degrade what appeared to be an excellent vantage point. The requirement for all-round defense must be met, because the enemy can fire from many directions and because enemy infiltration attempts must be countered.
 - (2) Cover and concealment are excellent for both the attacker and defender. However, the defender has a decisive advantage; the attacker normally must expose himself during movement through the area.
 - (3) Avenues of approach that remain inside buildings are best. Movement there is less easily detected than movement through the streets. The sniper must be conscious of ALL avenues of approach and must be prepared to engage targets that appear on any of them.
- b. Snipers should be positioned in buildings of masonry construction. These buildings should also offer long-range fields of fire and all-round observation. The sniper has an advantage because he does not have to move with, or be positioned with, lead elements. He may occupy a higher position to the rear or flanks and some distance away from the element he is supporting. By operating far from the other elements, a sniper avoids decisive engagement but remains close enough to kill distant targets that threaten the unit. Snipers should not be placed in obvious positions, such as church steeples and rooftops, since the enemy often observes these and targets them for destruction. Indirect fires can generally penetrate rooftops and cause casualties in top floors of buildings. Also, snipers should not be positioned where there is heavy traffic; these areas invite enemy observation as well.
- c. Snipers should operate throughout the area of operations, moving with and supporting the companies as necessary. Some teams may operate independent of other forces. They search for targets of opportunity, especially for enemy snipers. The team may occupy multiple positions. A single position may not afford adequate observation for the entire team without increasing the risk of detection by the enemy. Separate positions must maintain mutual support. Alternate and supplementary positions should also be established in urban areas.

- d. Snipers may be assigned tasks such as the following:
 - (1) Conducting countersniper operations.
 - (2) Killing targets of opportunity. The sniper team prioritizes these targets based on their understanding of the commander's intent—for example, enemy snipers first, then leaders, vehicle commanders, radio men, sappers, and machine gun crews, in that order.
 - (3) Denying enemy access to certain areas or avenues of approach (controlling key terrain).
 - (4) Providing fire support for barricades and other obstacles.
 - (5) Maintaining surveillance of flank and rear avenues of approach (screening).
 - (6) Supporting local counterattacks with precision fire.
- e. Snipers can be valuable to commanders in operations other than war. Since collateral damage and civilian casualties are normally restricted by the ROE, the snipers can selectively kill or wound key individuals who pose a threat to friendly forces. This selective engagement avoids unacceptable civilian casualties or collateral damage. Targets often hide in the midst of the civilian populace, which makes them virtually invulnerable to US forces since destroying these targets would probably cause innocent casualties—for example, a lone gunman in a crowd who fires at soldiers manning a roadblock. The soldiers must first identify the gunman (this is nearly impossible from their vantage point). Then, without hurting innocent bystanders, they must stop him from continuing to fire or from fleeing. This is an easier task for an overwatching sniper than for the infantry on the ground. The sniper can look down on the crowd, use his optics to continuously scan, and employ precision fire to eliminate (kill or wound) the identified threat without harming bystanders. Though other unit optical systems may supplement the surveillance effort (Dragons and TOWs from the ground or from the upper floors of buildings), they do not engage the target for the previously stated reasons. The sniper rifle provides the commander with the ONLY system that can both identify AND engage the target. Also, after identifying the target, Dragons and TOWs still need time to guide a precision weapon or maneuver unit to the target to deal with it.

F-7. RIVER CROSSINGS

Sniper teams, by virtue of their observation and precision-fire capabilities, are uniquely adaptable to the initial stages of a river crossing. They are normally employed in general support of the battalion both before and during the crossing.

- a. Snipers assume positions across the total width of the crossing area (if possible) before the crossing. Their main task is to observe. They should be located as far above or below possible crossing sites as is consistent with

observation and fields of fire. They report all sightings of enemy positions and activity immediately. Once again, they provide a stealthy observation capability not otherwise available to the commander. Their stealth prevents the enemy from learning what type of unit is trying to cross, and so on. They supplement normal reconnaissance assets.

- b. Snipers provide support during the crossing by continuing to observe and suppress enemy OPs and other key targets that might be overlooked by heavier supporting elements. The snipers' ability to continue to provide close-in suppressive fire makes continuous fire support possible up to the moment the far side is reached and elements begin their movement to establish the bridgehead line.
- c. Snipers should be positioned as early as possible, preferably as part of the reconnaissance force. Their movement across the river must also be planned in advance. How they will get across and where their subsequent positions will be must be coordinated. Generally, they displace once friendly elements reach the far side.
- d. Snipers are placed with elements controlling an air assault or boat crossing. The snipers expand the capability of the inserted force to engage threatening targets at long ranges. Their priority of engagement is generally the same as that for the remainder of the inserted force. Once on the far side, snipers may screen the flank or rear of the inserted force, infiltrate to destroy key targets, such as a demolition guard or fortified emplacements, or man OPs well to the front of the inserted force. This increases both early warning time and the inserted force's ability to disrupt enemy counterattack forces. This also confuses the enemy as to the type, strength, and location of the opposing force.

F-8. PATROLLING

The effective employment of sniper teams with any size or type patrol is limited only by the terrain and by the patrol leader's ingenuity. Snipers must know all aspects of patrolling.

- a. Snipers normally remain with the security element during reconnaissance patrols. If terrain permits, snipers can provide long-range support that will enable the reconnaissance element to patrol farther from the security element. To prevent compromise of the reconnaissance element's position, snipers only fire in self-defense or when ordered by the patrol leader. Normally, the only appropriate time to fire at a target of opportunity is when extraction or departure from the position is imminent and firing will not endanger the success of the patrol.
- b. Sniper employment on a raid is influenced by the time of day the raid is to be conducted and by the size of the patrol. When maximum firepower is needed and the size of the patrol must be limited, snipers may be excluded. If long-range precision fire is needed and patrol size permits, sniper teams may

be attached to the security element. If appropriate, the sniper team may be attached to the support element to help provide long-range supporting fires. When attached to the security element, the sniper team helps observe, helps prevent enemy escape from the objective area, and helps cover the withdrawal of the assault force to the rally point. When the element withdraws from the rally point, the sniper team may be left behind to delay and harass enemy counteraction or pursuit.

- c. Snipers are positioned during ambushes in areas that afford observation and fields of fire into terrain features the enemy might use for cover after the ambush has begun. The long range of the sniper rifle allows the sniper team to be positioned away from the main body. Sniper fires are coordinated into the fire plan. Once the signal to initiate fires is given, snipers add their fires to that of the rest of the patrols. Snipers shoot leaders, radio operators, and crew-served weapons teams. If the enemy is mounted, every effort is made to kill drivers of his lead and trail vehicles in order to block the road, prevent escape, and create confusion. Snipers may remain in position to cover the withdrawal of the patrol.

* APPENDIX G

EMPLOYMENT OF THE ANTIARMOR COMPANY

The purpose of the antiarmor company is to provide accurate, long-range antiarmor fire support to reinforce the battalion's antiarmor fires. The Army fights by combining fire and maneuver. Doing this requires a support-by-fire force and a maneuvering force. The mission of the support-by-fire form is to reduce the enemy's ability to interfere with the movement of the maneuver force and, within the capabilities of the support-by-fire force, to destroy the enemy's ability to fight. The mission of the maneuvering force, which may consist of both infantry and armor, is to close with and destroy the enemy. The antiarmor company can fulfill the support-by-fire requirement, enabling the task force to mass its infantry, BFVs or tanks to maneuver at the decisive point. This appendix discusses the employment of the antiarmor company in mechanized infantry battalions. Because any leader may have to assume command in combat, the term "leader" refers to all antiarmor leaders from the company commander down. Except when stated otherwise, the term "commander" refers only to the antiarmor company commander. Each commander sets an example of competence and professionalism while preparing his soldiers to fight. He must know how to best use the TOW in combat; he must know the abilities and limitations of his company's other equipment as well as how to best employ it.

CONTENTS	
PARAGRAPH	PAGE
Section I. COMMAND, CONTROL, AND PLANNING	G-2
G-1 Commander's Intent	G-3
G-2 Mission Tactics	G-3
G-3 Mission Orders	G-4
G-4 Main Effort	G-5
G-5 Planning Considerations	G-5
Section II. DOCTRINE	G-12
G-6 Mutual Support	G-12
G-7 Security	G-13
G-8 Flank Shot Engagements	G-13
G-9 Massed Fires	G-14
G-10 Standoff	G-15
G-11 Cover and Concealment	G-15
G-12 Employment in Depth	G-19
G-13 Employment as Part of a Combined Arms Team . . .	G-20
Section III. TACTICS AND TECHNIQUES	G-20
G-14 Offensive Operations	G-20
G-15 Defensive Operations	G-25
G-16 Retrograde Operations	G-31

PARAGRAPH	PAGE
G-17 Special Missions	G-35
G-18 Tactical Road March	G-36
G-19 Assembly Area Operations	G-37
Section IV. FIRE CONTROL	G-38
G-20 Principles of Fire Control	G-38
G-21 Coordination of Company Fires	G-39
G-22 Engagement Priorities	G-39
Section V. PROCEDURES	G-40
G-23 Security	G-40
G-24 Priority of Work	G-40
G-25 Positioning of TOW Vehicles	G-41
G-26 Types of TOW Missiles	G-43
Section VI. COMBAT SUPPORT	G-45
G-27 Engineer Support	G-45
G-28 Intelligence and Reconnaissance Support	G-45
G-29 Air Defense Support	G-46
G-30 Fire Support	G-46

Section I. COMMAND, CONTROL, AND PLANNING

This section discusses how the antiarmor company commander leads his company personally and through his XO, first sergeant, platoon leaders, and other subordinate leaders. He employs his company in combat based on orders from higher headquarters and on his METT-T analysis. In the absence of orders, he bases his actions on an understanding of the battalion mission and on his commander's intent and concept of the operation.

G-1. COMMANDER'S INTENT

The commander's intent drives mission tactics. His intent is his stated vision, which defines the purpose of the operation and the end state with respect to the relationship among the force, the enemy, and the terrain. It should also include how he expects this end state to support future operations.

- a. The overall purpose of the mission is more important than the individual assigned tasks. Each subordinate commander must know why and how his assigned tasks relate to the overall concept of the operation. Then, if his situation changes and he loses contact with higher headquarters, he can use his initiative to achieve the desired end results.

- b. The battalion commander has a dual responsibility. He must understand the intent of the brigade and division commanders (two levels up), and must ensure his intent is understood at company and platoon levels (two levels down). The commander's intent paragraph in the OPORD should begin with the words, "My intent is" to ensure subordinates can easily understand it.
- c. A clear commander's intent increases agility and initiative, and improves timing at all levels. It helps in shifting the main effort on a fluid battlefield.

G-2. MISSION TACTICS

The purpose of command and control is to allow the commander to generate and apply combat power at the decisive point on the battlefield. Mission orders are used to provide command and control to (directing) military operations. Subordinates are encouraged and expected to act alone to execute assigned missions, consistent with the intent of the next two senior commanders. The commander must—

- a. Anticipate a free-willed opponent and expect the unexpected. The enemy sometimes fails to follow his doctrine or act as IPB indicates he will. The commander must be flexible. War games, contingency plans, employment in depth, well-developed and rehearsed SOPs and a reserve all contribute to flexibility.
- b. Organize and direct operations to require minimum intervention. When precise control is required for synchronization, such as an on-order task, provide the subordinate with the criteria for making the decision.
- c. Allow time for subordinate planning. The one-third/two-thirds rule applies not only to OPORDs but also to rehearsals, briefbacks, or any other centralized events that reduce subordinates' preparation time.
- d. Assign resources with as few restrictions on employment as possible. Allocate assets and support priorities to subordinates, and specify only the desired results.
- e. Allow maximum freedom of action within the scope of his intent. Because battles often develop in unforeseen directions, leaders must often act with incomplete information or instructions. They must act quickly or risk not generating sufficient combat power at the decisive point in time. Taking advantage of opportunities in order to accomplish the mission is not only allowed but also encouraged, expected, and sometimes required. Leaders should try to inform their higher commander before they act.
- f. Structure communication to allow subordinates to command well forward. Position himself on the battlefield where he can exert the greatest influence, both directly and through subordinate leaders. At the same time, he must retain the ability to shift the main effort of the battle. He can locate forward with the lead platoons in the command group, or he can locate in the main

CP. Whatever else he does, he must be able to command and control all organic and supporting units equally from either location.

G-3. MISSION ORDERS

Army operational doctrine requires mission tactics. Decentralization provides subordinates the latitude to make decisions rapidly within the framework of the commander's concept and intent.

- a. Mission orders address only the required information. They provide the framework of *what* the commander wants done—not *how* it is to be done. Such orders need cover only three important things. *First*, they must clearly state what the commander issuing the order wants accomplished. *Second*, they must point out limiting factors that must be observed for coordinating purposes. *Third*, they must state what resources are to be made available to the subordinate commander and what support he can expect outside his command.
- b. Execution of mission tactics requires initiative, resourcefulness, and imagination. Commanders must be ready to adapt to situations as they find them, not as they expected or desired them to be.
- c. Subordinate leader initiative is based on mission orders and the commander's intent. These define the limits of company operations and provide the opportunity for a subordinate to take advantage of opportunities on the battlefield. The subordinate leader must be positively aggressive. He asks his commanding officer for information, resources, or revision of plans as needed and stands up for his position when he feels he is right.
- d. Though initiative and independence are encouraged, subordinates are limited by the requirements for unity of command and unity of effort, and by the commander's intent. Subordinates who feel they must disobey orders due to a perceived change in the situation must accept the responsibility for their actions. The commander's intent must be clearly stated and foremost in the minds of subordinate leaders. To win, subordinate leaders must display initiative, but this initiative must be driven by an understanding of the commander's intent, not by a desire for independent action. If independent action is required in order to meet the commander's intent for the operation, that action must be taken. However, subordinate leaders must weigh the changing tactical situation against the need for synchronized unit action. They must look at the "big picture." Thus initiative and freedom of action are more likely used during an exploitation or pursuit; disaster could result for the entire force if an independent action is conducted during a delay or withdrawal under enemy pressure.
- e. Commanders normally use mission-type orders. However, due to the requirement for synchronization of the overall mission, they must occasionally give subordinates specific instructions on how to accomplish a mission.

G-4. MAIN EFFORT

The company with the most important task in the battalion commander's concept at a particular time is designated as the main effort. All other units support the quick success of this company. Subordinate commanders link their actions to the actions of those around them, but leave room for initiative. They base their decisions about independent actions on how their unit relates to the main effort. Success by the main effort at the decisive point should result in the success of the company's mission. If conditions change and success of the overall mission can be obtained more cheaply or quickly another way, the battalion commander shifts the main effort to another unit. Support priorities then change to ensure the success of the newly designated main effort.

G-5. PLANNING CONSIDERATIONS

The antiarmor company commander uses troop-leading procedures to plan, coordinate, execute, and supervise operations. He must know what tasks an antiarmor company can perform.

- a. **Troop-Leading Procedures.** Troop-leading procedures are continuous and begin on receipt of the mission. The company commander uses these procedures to plan, coordinate, execute, and supervise operations. They need not be performed in a specific order, nor does each of them have a clear beginning. For example, the commander can issue a warning order while conducting his estimate of the situation.
 - (1) **Receive and analyze the mission.** The company commander receives a mission in an oral or written battalion OPORD, FRAGO, or warning order. On receipt of this order, he begins his estimate of the situation and plans how to use available time.
 - (a) The commander uses the information available in the battalion OPORD to determine the mission, its purpose, and the inherent constraints on his company. This information comes from the battalion's *mission statement*, from battalion and brigade commanders' *intents*, and from the *coordinating instructions*. The commander then considers METT-T and other relevant factors to determine implied missions. Using this information, he determines how to restate the mission for his company and how to accomplish the mission.
 - (b) Time is the most crucial resource for a unit receiving a new mission. The leader should use only one-third of his time for company planning in order to allow subordinates the remainder to make their plans. For example, a company commander given nine hours should use no more than three, which leaves six for subordinates to plan, reconnoiter, and issue their orders. This one-third/two-thirds rule increases the chance for mission success; it allows time for the whole company to receive

and understand the commander's intent and concept. This creates a sense of purpose in the company, which makes it more effective.

- (2) **Issue the warning order.** As soon as he receives a warning order or other information about an impending mission, the company commander issues his warning order explaining the restated mission. Warning orders are issued through the chain of command to ensure all personnel are informed. No standard format exists for a warning order. However, it should include the situation, the mission, general instructions (earliest time of movement, OPORD location and time), and special instructions. If time is too short for a new FRAGO or OPORD to be issued, the warning order may include new information.
- (3) **Develop a tentative plan.** The company commander's tentative plan states how he intends to accomplish the mission. He must analyze the factors of METT-T. Developing the plan is not a mechanical process; it requires the commander to use his judgment. The product of this step is the commander's *concept of the operation*. This is based on the commander's knowledge of the situation, on the mission analysis, and on the estimate of the enemy situation. The estimate is based on patrol reports and on information from the battalion S2. The commander continues by developing several courses of action (COAs) and selecting one to be his tentative plan. He can change the plan based on the leader's reconnaissance or on new information. The tentative plan provides the concept of operation, a scheme of maneuver, and a fire support plan, and is the basis for coordination, unit movement, reorganization, and reconnaissance. The mission statement includes the *who, what, when, where, and why* of the mission. The company commander has no staff, but he can discuss his plan with subordinates or attached personnel. This serves also to give subordinates a better view of the commander's concept and to give attached personnel a chance to advise in their areas of specialized knowledge.
- (4) **Begin necessary movement.** The company commander acts quickly and efficiently so his platoon leaders can move, reconnoiter, and prepare their squads. If the company must move a great distance before the operation, it should move as soon as it receives the battalion's warning order. If the company is to participate in a tactical or strategic airlift, preparations should begin as soon as the company warning order is issued. This permits the company commander and the platoons to arrive at the terrain early. When the commander is called to receive his order, he takes the company XO with him. The XO returns to the company with the warning order and, in the absence of the commander, moves the company. The first sergeant supervises the logistical operations. This includes fuel, ammunition, medical needs, maintenance requirements, transportation, and food support. Meanwhile, the commander reconnoiters, checks his plan, and issues his final order. Many of the tasks involved in a tactical movement are routine and should be part of the company SOP.

- (5) **Reconnoiter.** A commander must sometimes issue orders based on a map reconnaissance. He should do this only when a ground reconnaissance cannot be conducted; the ground reconnaissance shows the commander whether his concept will work on the terrain. The commander takes his platoon leaders and a security force with him during a reconnaissance. They travel by covered and concealed routes to one or more vantage points and observe the terrain. The security force provides overwatch while the leaders reconnoiter. If neither ground nor air reconnaissance is possible, then the commander should request all new information on the terrain such as detailed maps and photo reconnaissance.
 - (6) **Complete the plan.** Reconnaissance may change the plan and add detail. New information is used to refine the tentative plan and to make any final changes to the operation.
 - (7) **Issue orders.** A company commander rarely issues written orders. Normally, he prepares his notes in the five-paragraph order format and gives an oral order. He should give the order first to his orders group, which consists of the XO, the platoon leaders, the first sergeant, and the leaders of attached units. The graphics that support the operation should be on the commander's maps already and should be copied onto subordinates' maps before the order is given. The commander should use one of two methods to give his concept of the operation. He should either use a terrain model or sketches, or he should overlook the area of operations, using it to illustrate his concept while he gives the OPORD. This ensures that subordinates understand the concepts of maneuver for their unit and other units. By having his subordinates brief him back or walk through the plan, the commander can ensure they understand it.
 - (8) **Supervise.** A leader supervises preparation (precombat checks and rehearsals) and execution of the mission. Constant supervision is as important as issuing the order. Officers and NCOs ensure that all phases of preparation are complete.
- b. **Mission.** A mission consists of the company's primary task and purpose. To clarify his company's mission, the commander may add other mission-essential elements such as time, place, or unit identification.
- c. **Tasks.** Tasks are components of a mission. FM 25-100 states that a task is "a clearly defined, observable, and measurable activity accomplished by units or forces." It then states that, "A task contributes to other activities or missions." A task is what defines the mission so that the mission is attainable. A task describes a desired effect on the enemy, the terrain, or friendly forces. A company's mission-essential task is the one that, when completed, fulfills the company's purpose within higher headquarters' concept of the operation. An operation is not a task. The most common antiarmor tasks areas follows:
- (1) **Support by fire.** The battalion commander designates the position and orientation of positions and orients direct-fire weapons on an objective or

into an engagement area. To further clarify this task, he includes a qualifying task. For example, instead of simply saying, "Support by fire," he will say, "Support by fire to fix."

- (a) **Support-by-fire to fix.** The battalion commander may assign an element to provide antiarmor support-by-fire to fix. The company's purpose is to prevent the enemy from moving any part of his forces for a specific period of time, from a specific location, or both, by holding or surrounding him.
 - (b) **Support-by-fire to attrite.** The battalion commander may assign the company to provide antiarmor support-by-fire to attrite the enemy. The company's purpose is to reduce the effectiveness of the enemy by destroying his personnel or materiel.
 - (c) **Support-by-fire to suppress.** The battalion commander may assign a company to provide antiarmor support-by-fire to suppress. The company's purpose is to use direct or indirect fire, electronic countermeasures, or smoke on enemy personnel, weapons, or equipment to prevent them from firing effectively on friendly forces.
- (2) **Overwatch.** The battalion commander positions the antiarmor company to support with immediate direct fire the movement of another company.
 - (3) **Screen.** The battalion commander tasks the company to maintain surveillance, provide early warning to the main body, impede and harass the enemy with supporting indirect fires, and destroy enemy reconnaissance units.
 - (4) **Conduct counterreconnaissance.** The battalion commander tasks a company to prevent hostile observation and detection of a force, area, or location by visual, electronic, sonic, or other means. He gives the counterreconnaissance force commander specific tasks such as "destroy" or "deny," rather than the general task, "conduct a counterreconnaissance."
- d. **Positions on the Battlefield.** One of the biggest challenges faced by a commander is deciding where to position his platoons on the battlefield. This decision must be based on an analysis of the terrain, must include measures to protect the weapons systems, and must ensure mutual support between platoons.
- (1) **Analyze terrain.** The first consideration in positioning the TOW system is to exploit every advantage offered by the terrain for using the tank-killing capabilities of the TOW.
 - (a) **Armor avenues of approach.** The commander must analyze all armor avenues of approach into the battalion sector. This should include all trafficable areas that provide cover and concealment such as woods or draws the enemy could use to counter the TOW. The commander should analyze the terrain from the enemy's point of view—for example, what size force can be deployed and controlled on the

approaches, and where are the positions that can be used for overwatch? He can obtain much of this information from the IPB performed by the battalion S2.

- (b) **Engagement areas.** Once he has analyzed the terrain from the enemy's perspective, the company commander must next analyze it to identify potential armor engagement areas. He selects areas along the avenues of approach where the enemy will be most vulnerable to concentrated antiarmor fires. The areas the commander selects influence how he will deploy his forces in the defense. Therefore, after he participates in the initial estimate process with the battalion commander, the company commander recommends antiarmor engagement areas based on his terrain analysis. The antiarmor engagement areas the battalion commander selects may be forward of the FEBA or within the main battle area. Their locations determine where the battalion commander should allocate supporting fires and where obstacles and mines should be placed.
 - (c) **Flank shot positions.** The commander selects flank shot positions throughout the depth of the battle area. From these positions, antiarmor platoons will engage the enemy as he moves deeper into the main battle area. The positions selected must give the TOWs good fields of fire into the engagement areas; they must offer flank and rear shots along the avenues of approach and be located for mutual support and for support by other weapons systems. The company should be able to mass fires into the engagement areas while keeping the TOW systems dispersed in the main battle area.
- (2) **Protect the TOW systems.** To survive and contribute to the defense, the TOW systems must be positioned where they are protected from enemy direct and indirect fire and from mounted or dismounted assault. If possible, engineer support should be obtained for constructing survivability positions.
- (a) The positions must be on terrain that provides natural or man-made cover and concealment. In the defense, use of concealment is the best way to surprise the enemy. When the scheme of defense is concealed, the enemy has trouble coordinating his fires and maneuvering his platoons against specific targets. Using fires from flanking positions and properly using the TOWs standoff are excellent ways to provide protection from enemy fires.
 - (b) Protection from mounted assaults is gained by positioning the TOW system on terrain that restricts the movement of vehicles. Restricted terrain includes such features as forested or built-up areas, marshy ground, or steep slopes. Engineer support may be available to improve fields of fire or to create or improve obstacles.
 - (c) Three methods can be used to defend the TOW systems from dismounted infantry attack. The first is to position antiarmor squads

or sections with the infantry units. The second is to position infantry along avenues of approach leading to the TOW positions. The third is to reposition reserve or uncommitted forces to counter dismounted attacks after they have been discovered.

- (3) **Provide mutual support.** Mutual support provides some protection for weapons and crews by ensuring complete, continuous coverage of engagement areas and avenues of approach. TOWs are positioned so that their fires interlock with the fires of other TOWs and antiarmor weapons systems (tanks, Dragons, AT4s). Also, they are positioned so that their fires can engage enemy armored vehicles assaulting other TOW positions.
- (4) **Reduce vulnerability.** The commander does the following to reduce vulnerability to enemy suppressive fire:
 - (a) Avoids positioning platoons on easily targeted terrain features.
 - (b) Designates on-order platoon positions throughout the battle area to aid in quickly redeploying platoons once they have been targeted.
 - (c) Selects positions masked by terrain from which to fight.
 - (d) Enforces use of camouflage, concealment, and OPSEC.
 - (e) Plans movement on covered routes to subsequent positions.
 - (f) Plans use of smoke to obscure movement and to suppress likely enemy overwatch positions.
- (5) **Identify phase lines for disengagement.** Disengagement is breaking contact with the enemy and moving where the enemy can neither see nor engage the unit. The company disengages when it is directed by higher headquarters to move to a subsequent BP or to accomplish another mission elsewhere (withdrawal, retrograde, or counterattack). The company commander must identify phase lines where platoons must disengage in addition to selecting their primary and alternate positions. He chooses these lines so he knows when to order his platoons to move to their next positions. The location of these phase lines is based on the threat and on the terrain. If the commander wants his platoons to displace before they move within tank or BMP range, then he must determine where the Threat will be when he orders the platoons to move. If the terrain is open and unrestricted, the line must be farther out to allow the platoons time to displace. Conversely, if existing or reinforcing obstacles are located in front of the platoon position, the line can be closer.
 - (a) The company commander establishes rules for disengagement in case communications are lost—for example, he might tell the platoon and squad leaders to displace, with or without orders, when the enemy reaches a certain line on the ground.

- (b) Disengagement from terrain-masked positions is simplified, because units are protected to their front from enemy direct-fire weapons. However, smoke could be used to conceal movement under any circumstances.
- (c) The company commander should have his platoons rehearse the disengagement to ensure all squads know where to go and what route to use. Soldiers also fully understand how the battle will be fought if they rehearse it. Rehearsals ensure that TOWs can get to their alternate positions without being overtaken during repositioning.
- (d) When disengaging, the company coordinates its moves with units to its flanks and rear.
- (e) The disengagement plan should be simple. The commander chooses one technique or a combination of techniques to disengage. He may choose to disengage by *internal overwatch*. With this method, platoons disengage with least engaged platoons first to overwatch positions to support disengagement of platoons remaining in contact. Platoons in contact disengage and move until contact with the enemy is broken. The commander may choose to disengage by leaving one platoon or element in contact to cover the disengagement while the other platoons break contact. The designated *detachment left in contact (DLIC)* disengages next, using internal overwatch to cover its move back until contact is broken. This technique is not normally used when under heavy enemy pressure. He may plan to conduct the disengagement during *limited visibility* to cover the disengaging force. He should plan to use on-board smoke or to deliver smoke by artillery or mortar to cover the movement of the disengaging force. He should also use *obstacles*. Or, he can place himself during the disengagement where he can best control his company. He normally locates with the majority of his company and may place the XO with the disengaging element. When more than one platoon executes the disengagement, the company commander places himself with the larger element.
- (6) **Engage the enemy from the flank.** Frontal fire must be avoided. It attracts attention and is therefore deadly. The weapon should be able to fire from the flank. It should also be sited so that it is in defilade from the enemy's direction. Neither trailing tanks nor overwatch forces must be able to see the TOW launch signature—concealing it is vital.

Section II. DOCTRINE

Following the basic rules of antiarmor unit employment increases the probability of destroying targets and enhances the survivability of the antiarmor elements. This section discusses these basic rules.

G-6. MUTUAL SUPPORT

Antiarmor squads support each other due to their assigned tasks, their relative positions (with respect to each other and to the enemy), and their inherent capabilities. Mutual support is established when TOWs are employed by section and when sectors of fire are overlapped between sections.

- a. **Employment by Section.** Employment of TOWs by section establishes mutual support between two squads (Figure G-1). If one squad is attacked or forced to displace, the other can continue to cover the assigned sector. To achieve this, the squads are positioned so that fires directed at one squad suppress only that squad.

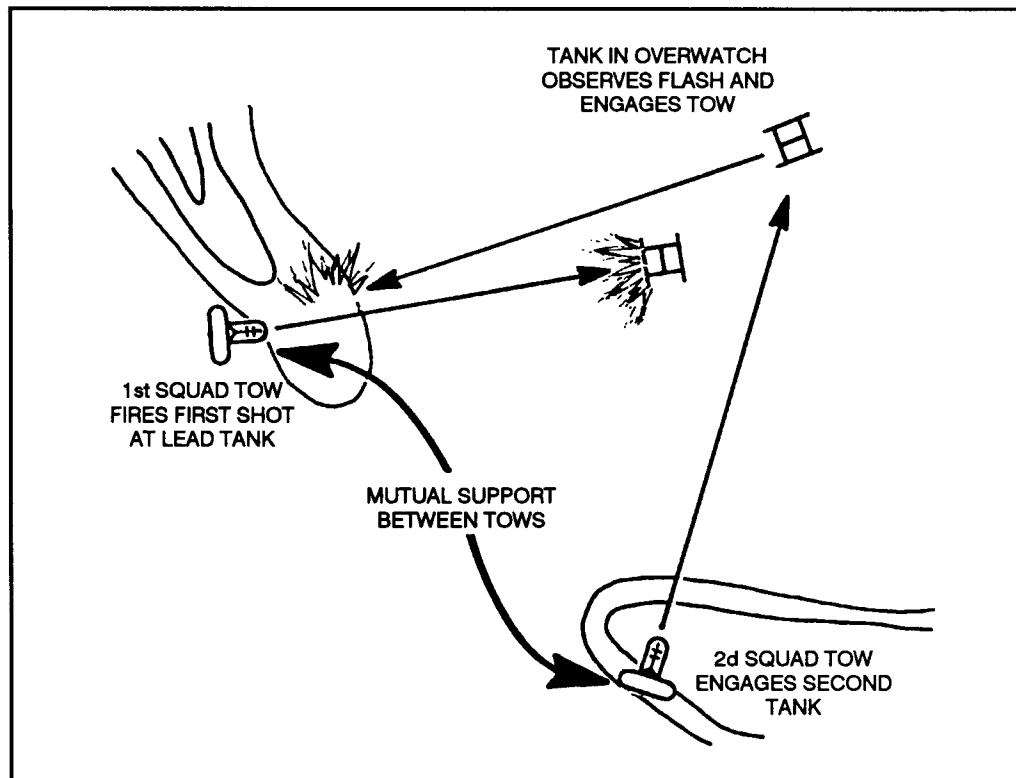

Figure G-1. Employment by section.

- b. **Overlapping Sectors of Fire.** Overlapping sectors of fire are vital to mutual support (Figure G-2). Primary, alternate, or secondary sectors of fire are used.

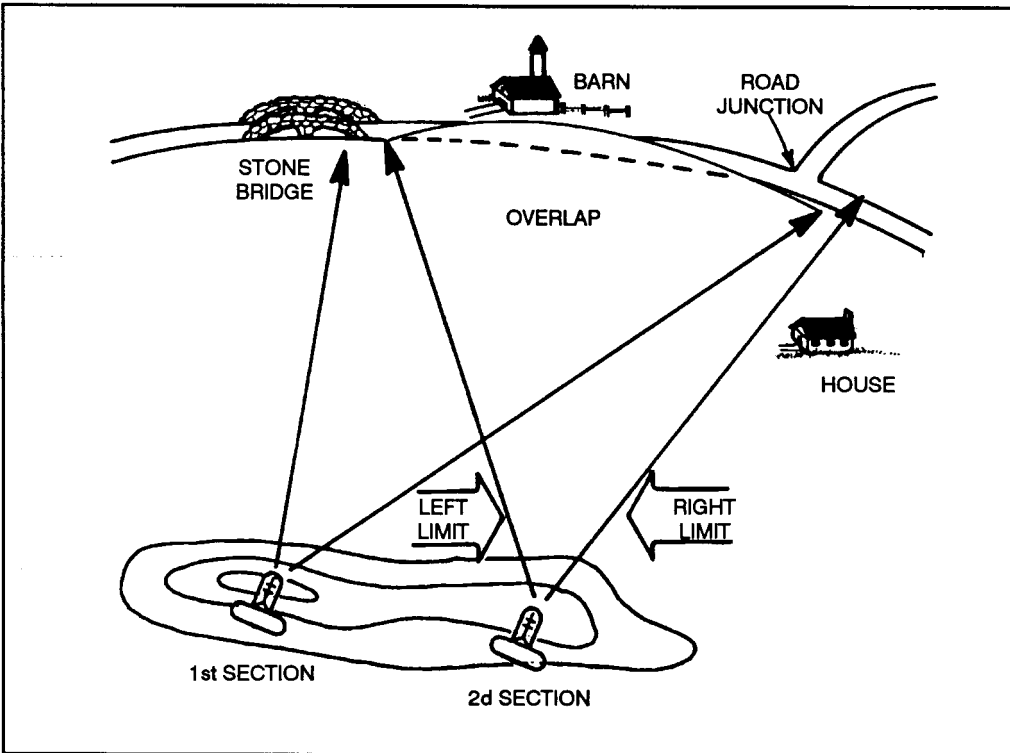

Figure G-2. Overlapping sectors of fire.

G-7. SECURITY

Antiarmor units can be attacked by dismounted enemy infantry. For protection, they should be positioned near friendly infantry units. Though they are not required to collocate with antiarmor squads, the infantry should cover dismounted avenues of approach to the antiarmor positions. Antiarmor units moving with infantry provide their own local security. During halts, the driver/loader dismounts to secure flank and rear sectors. The consequences of omitting this protective measure can be costly. Without flank and rear security during movement, whole antiarmor sections or platoons could be destroyed by as few as one enemy vehicle.

G-8. FLANK SHOT ENGAGEMENTS

Antiarmor squads and sections must be positioned to engage tanks or armored fighting vehicles (AFVs) from the flank. Flank shots at enemy tanks or AFVs

are more desirable than frontal shots (Figure G-3). An enemy tank or AFV is most vulnerable from the flank because it—

- a. Has its greatest armor protection in the front.
- b. Is oriented to the front—this applies to vision ports, laser range finder, crew, and firepower.
- c. Is less likely to be killed if engaged from the front.
- d. Is more likely to detect and suppress the attacking antiarmor units if engaged from the front.
- e. Creates a larger target from the flank.

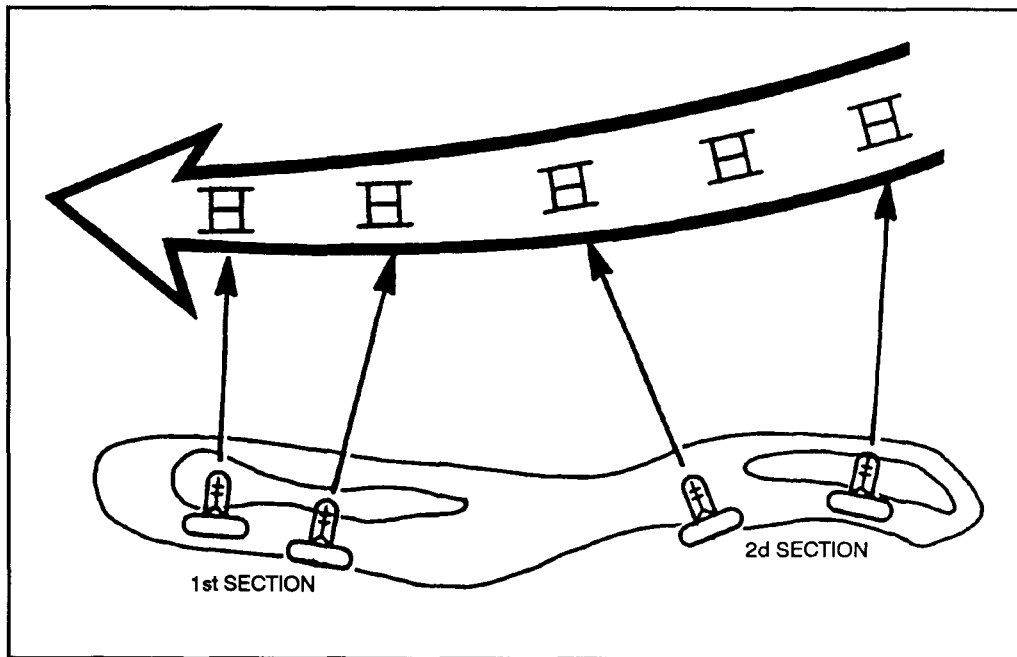

Figure G-3. Engagement from the flank.

G-9. MASSED FIRES

Mass is achieved by concentrating the effects of combat power at the decisive place and time to gain favorable results against the enemy. The antiarmor company achieves mass through mutual fire support, detailed fire control, and fire distribution measures synchronized with the combat elements of the supported unit.

G-10. STANDOFF

The advantage of firing a TOW rather than a tank's main gun is the accuracy of the TOW beyond the main gun's effective range—2,400 meters. This range advantage, or *standoff*, is the difference between the tank's maximum effective range and the TOW's maximum range (Figure G-4). TOW standoff does not require gunners to engage armored vehicles between 2,000 meters and 3,750 meters. This may not always be tactically feasible. The TOW missile requires extra tracking time to travel beyond 2,000 meters; this increases the likelihood of gunner error. For frontal shots, this gives the enemy more reaction time to maneuver against the friendly position. For flanking shots, this gives the enemy more time to reach cover. These difficulties increase if the gunner has to track the missile through his thermal nightsight or through any form of obscurity.

- NOTES:
1. Threat armored vehicles, such as the T-55 modernized, the T-64B, the T-72S, the T-80 main battle tank, and the BMP-3, can fire ATGMs through their main gun tubes. These missiles have ranges up to 4,000 meters, which negate the TOW's standoff.
 2. Threat armored vehicles can fire HE-fragmentation rounds to suppress TOW gunners at ranges greater than 4,000 meters. Some countries have HE warheads for their ATGMs. Also, turreted mortars provide direct fire, direct lay, and indirect fire.

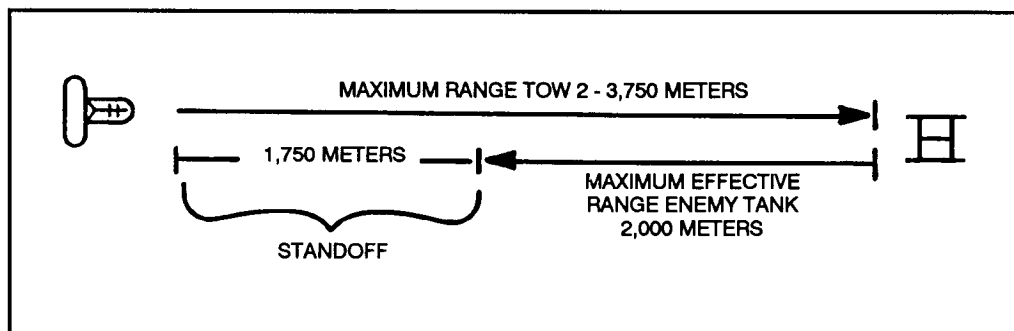

Figure G-4. Standoff.

G-11. COVER AND CONCEALMENT

Cover and concealment are critical to the survival of antiarmor weapons systems. The TOW system has several weaknesses: The missile has a long flight time; the TOW launcher has a slow rate of fire; the TOW missile has a distinctive firing signature; and the gunner is exposed during tracking—except in the ITV or BFV. The effects of these weaknesses can be reduced if the TOW system is covered and concealed, so leaden should look for appropriate terrain. Conspicuous terrain features should be avoided such as lone buildings or trees, hilltops, and other obvious positions. To further reduce their vulnerability to enemy fire, antiarmor weapons should be dispersed laterally and in depth so that

no two weapons can be suppressed at the same time by a single weapon. If possible, antiarmor squads should be at least 300 meters apart (Figure G-5). This reduces the casualties and the equipment damage that could result from an artillery barrage. These aspects of cover and concealment also apply to movement and route selection.

NOTE: The analysis of cover and concealment is often inseparable from the analysis of fields of fire and observation. TOW positions must be both effective and survivable.

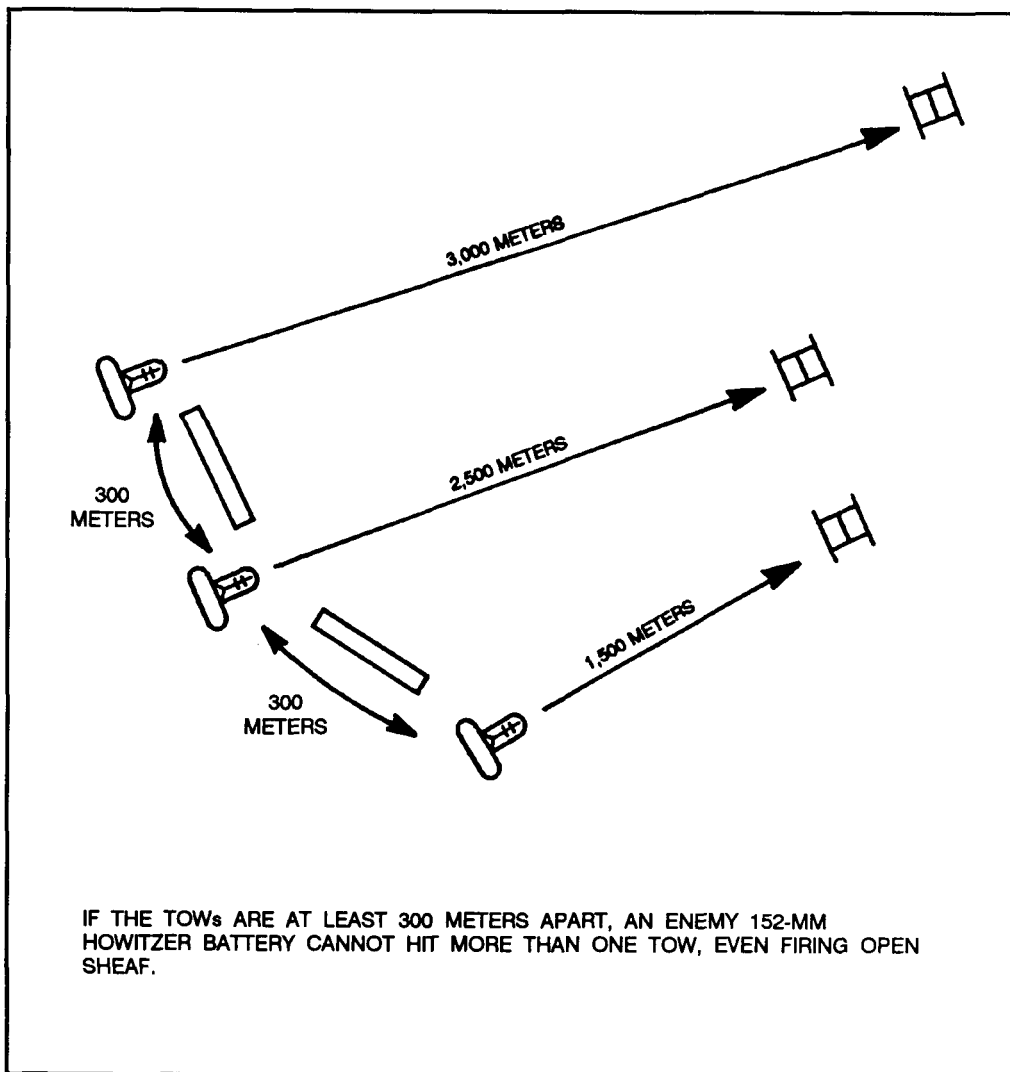

Figure G-5. Dispersion between squads.

- a. Offensive considerations include the following:
- (1) Determine the routes with good cover and concealment.
 - (2) Identify areas along the approaches to the objective that offer poor cover and concealment.
 - (3) Consider the use of smoke and limited visibility missions to provide concealment.
- b. Defensive considerations include the following:
- (1) Focus on the locations with good fields of fire.
 - (2) Think about how the enemy can use the available cover and concealment.
 - (3) Look at the position from the enemy's point of view, both day and night.
- c. Cover is protection from the fire of enemy weapons and from enemy observation (Figures G-6 and G-7). Cover may be natural or man-made. Natural cover includes reverse slopes, ravines, and hollows. Man-made cover includes fighting positions, walls, rubble, and craters.

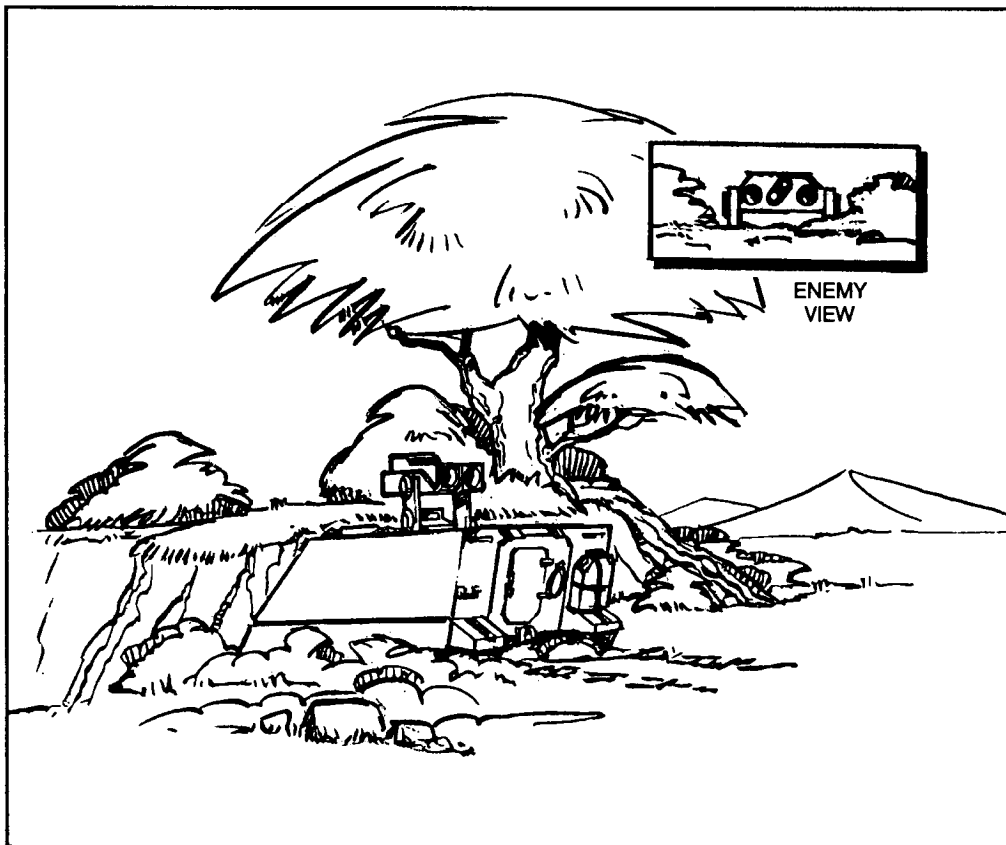

Figure G-6. Cover.

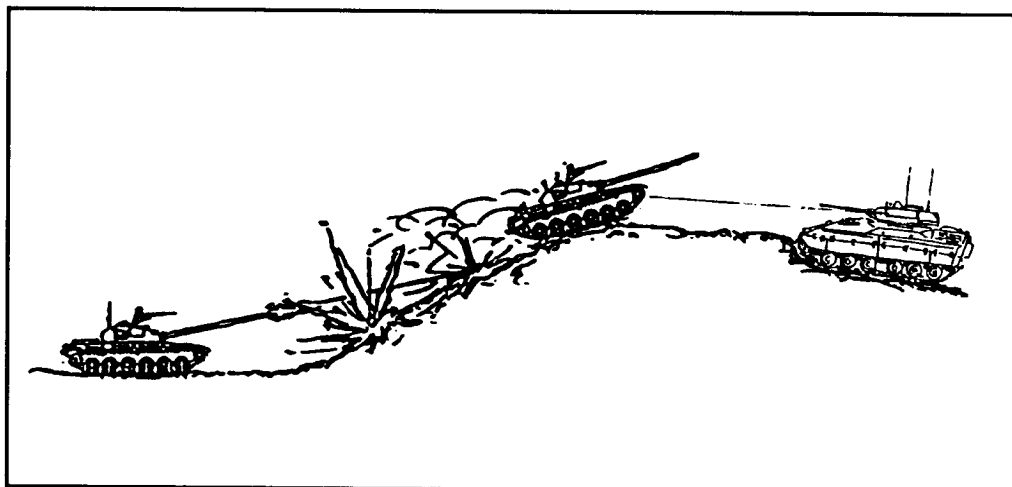

Figure G-7. Reverse slope.

- d. Concealment is protection from observation (Figure G-8). It is anything that hides a soldier, unit, or position from enemy ground and aerial observers and gunners. NVDs and other detection devices penetrate darkness and prevent it from providing sufficient concealment. Leaders must choose inconspicuous positions that do not silhouette TOW launchers against the skyline. The principles of concealment include the following:
- (1) **Avoid unnecessary movement.** Movement attracts attention. A concealed TOW position may be detected easily if the launcher is traversed or raised or if any other unnecessary movement occurs. Moving against a stationary background makes objects stand out.
 - (2) **Use all available concealment.** Background is important. To prevent detection, the position must blend with the varied color and appearance of the trees, bushes, grass, earth, and man-made structures that form the background. A TOW position located in the open stands out clearly, but a sniper in the shadows is difficult to see. Shadows exist under most conditions, day and night. A TOW should never be fired from the edge of a wood line; it should be fired from a position inside the wood line (hidden in the shade or shadows provided by the treetops).
 - (3) **Stay low to observe.** The enemy has difficulty seeing a position with a low silhouette. To observe, the TOW leader should move forward.
 - (4) **Expose nothing that shines.** A reflection of light on a shiny surface instantly attracts attention and can be seen from a great distance. Optics should be used cautiously in bright sunshine due to the reflections they cause. At night, NVDs can even detect light emitting from the instrument panels inside ITVs.

- (5) **Avoid skylining.** Figures and vehicles on the skyline can be seen from a great distance, even at night, because a dark outline stands out against the lighter sky. A person's silhouette makes a good target.
- (6) **Alter familiar outlines.** Both military equipment and people provide familiar outlines to the enemy.
- (7) **Keep quiet.** Noises such as talking, idling vehicles, or touching metal to metal can be heard by enemy patrols or listening posts.

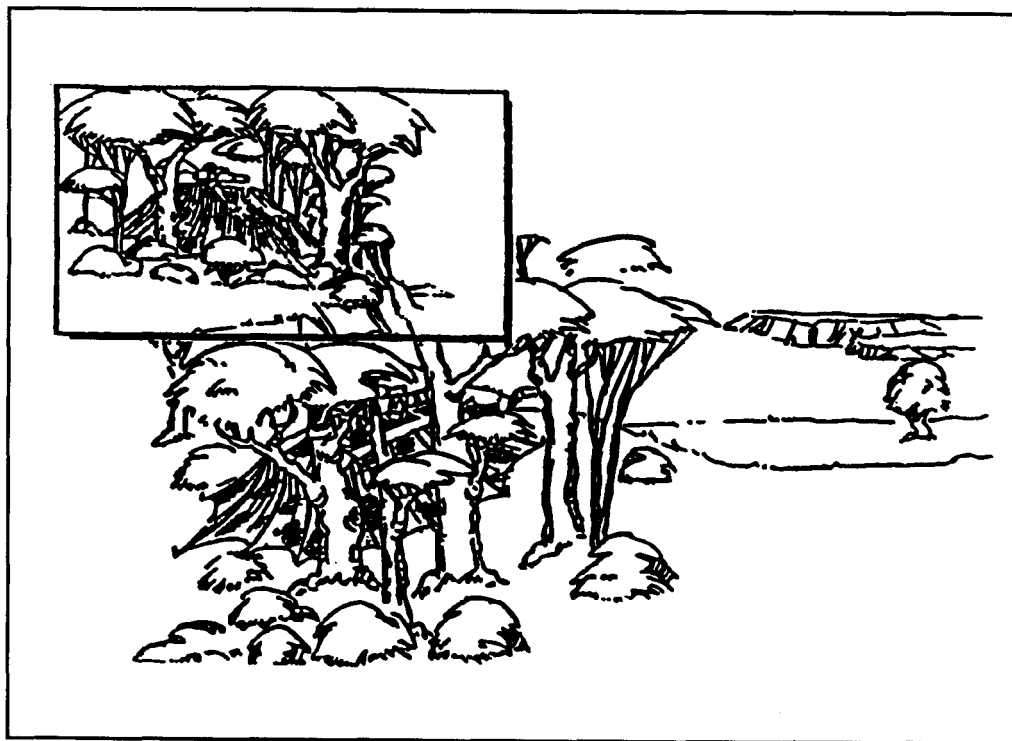

Figure G-8. Concealment.

G-12. EMPLOYMENT IN DEPTH

Antiarmor fire should be employed in depth. In the offense, routes and firing positions should be selected to support the forward movement of attacking units. In the defense, antiarmor squads may be initially positioned forward (then moved to in-depth positions as the enemy closes) or in depth.

G-13. EMPLOYMENT AS PART OF A COMBINED ARMS TEAM

Skillful integration of infantry, BFVs armor, engineer, and indirect-fire assets greatly improves the survivability and lethality of antiarmor units.

- a. **Infantry.** Infantry is needed to provide local security, to emplace obstacles (wire and mines), and to engage dismounted infantry and armor.
- b. **Engineers.** Engineer assets help shape the engagement area by emplacing tactical obstacles. These obstacles are employed to reduce the enemy's ability to maneuver, mass, and reinforce as well as to increase his vulnerability to fires. To accomplish this, obstacles must either disrupt, fix, turn, or block the enemy. The engineers emplace the obstacles inside designated obstacle zones, belts, and groups. To be effective, the obstacles must be covered by both direct and indirect fire.
- c. **Indirect Fires.** The antiarmor company commander must be part of the indirect fire planning process at company and battalion. He must coordinate frequencies, call signs, and priorities of fire. Any antiarmor leader can request indirect fires. To do this, he must contact either the battalion mortar platoon, the FIST of a designated task force tank/infantry team, or the DS artillery battalion. Indirect fires (artillery and mortars) are used for several purposes.
 - (1) To destroy or neutralize the enemy.
 - (2) To slow the enemy rate of advance.
 - (3) To breakup enemy formations.
 - (4) To cause enemy vehicles to button up.
 - (5) To suppress accompanying enemy artillery and ATGM support-by-fire.
 - (6) To fire obscurants (WP/HC smoke) to help conceal friendly launch signatures and to cover movement of TOW squads between positions. However, obscurants can degrade the capability of the TOW.

Section III. TACTICS AND TECHNIQUES

This section discusses some of the offensive and defensive methods used in the employment of antiarmor units.

G-14. OFFENSIVE OPERATIONS

Destroying the enemy's fighting force is the only sure way of winning therefore, the main purpose of an attack is to destroy enemy forces. The antiarmor company serves as the support-by-fire unit for the assault. It overwatches or supports by fire the maneuver or assault force of the battalion task force from

positions chosen by the task force and the antiarmor company commander. The antiarmor company places destructive or fixing fires on known and suspected enemy positions, adjusts indirect fires to support the maneuver force, and protects the maneuver force against counterattacks. The success of the attack depends in part on how well the commander understands the dynamics of battle. Success also depends on how the commander applies the operational concepts of an attack during both its planning and execution phases.

- a. **Purpose.** Infantry battalions conduct offensive operations for the following reasons:
 - To defeat enemy forces.
 - To secure key or decisive terrain.
 - To deprive the enemy of resources.
 - To gain information.
 - To deceive and divert the enemy.
 - To hold the enemy in position.
 - To disrupt an enemy attack.

- b. **Planning.** Planning operations at company level involves less detail than at battalion level. Company commanders prepare their estimates and plans, using the one-third/two-thirds rule to allow time for subordinates to prepare theirs. Planning includes developing a scheme of maneuver and a fire support plan.
 - (1) **Scheme of maneuver.** The scheme of maneuver reflects the purpose of the mission and the commander's plan to position his platoons. The scheme has enough detail to ensure subordinates understand the purpose of the operation. The scheme of maneuver—
 - (a) Identifies objectives for platoons and assigns responsibilities and tasks.
 - (b) States the route and movement formations used to move from the LD to the objective. Routes chosen should offer cover and concealment, allow the unit to move rapidly, allow it to avoid obstacles and enemy kill zones, and allow it to mass combat soldiers on the enemy flank. Using movement formations allows the company the flexibility to react to different situations.
 - (c) Identifies the platoons' primary, alternate, and supplementary positions. Assigning positions allows the commander to direct TOW missiles onto the likely armor avenue of approach.
 - (d) Describes the commander's plans to use the platoon's fires to destroy the enemy in the battalion zone. The commander identifies TRPs and phase lines based on how he views the battle and intends to defeat the

enemy. He establishes disengagement criteria to prevent the company from becoming decisively engaged.

- (2) **Fire support plan.** The purpose of fire support is to optimize the employment of fire support systems. To do this, the commander integrates and synchronizes fire support with the battle plan. Because the antiarmor company seldom has an FSO, the commander must also implement the plan. He gives the battalion FSO the specific requirements for fire support and for tasks to support the company's concept of the operation. The commander plans fire support at the same time he develops the scheme of maneuver. During the planning process, the commander assesses available fire support assets (mortars, artillery, offensive EW, CAS, NGF, Army aviation, ADA and engineers), determines whether these assets can accomplish the tasks required, and determines which best support the scheme of maneuver. The key to effectively integrating fire support is to thoroughly and continuously include fire support in the planning process. To support the battle plan, the fire support plan covers suppressing, neutralizing, or destroying enemy direct-fire weapons systems, breaking up enemy formations, degrading enemy command and control, destroying enemy logistics sites, and screening company movement. Three stages of fires are planned—before the engagement (preparatory), during the engagement, and in support of the disengagement.
- (a) Before an engagement (assault), preparatory fire is delivered on targets. Preparatory fire consists of an intense volume of fire delivered IAW a scheme of maneuver. Factors influence the duration of preparatory fire such as the fire support needs of the entire force, the number of targets, and the type and amount of firing assets and ammunition available. These fires suppress enemy direct-fire weapons and support the movement of the company.
- (b) Fires during the engagement destroy, neutralize, or suppress enemy weapons, isolate the enemy within the engagement area, stop or delay second-echelon forces from reinforcing the enemy, and reduce the enemy's counterattack ability.
- (c) Gunners supporting a disengagement concentrate on likely enemy counterattack and withdrawal routes. This helps destroy the enemy and allows the units to withdraw to new positions. During this stage, fires screen the company's movement (TC 6-71). Fire support considerations include the following:
- Number and type of fire support units available.
 - Number of combat observation and lasing teams (COLTs) assigned.
 - Priority targets.
 - Priority fires.

- Identification and timing of preparatory fires.
- Use of nuclear and chemical fires (by higher headquarters).
- Effect of fires in creating obstacles.
- Close air support.
- Timed fires.
- High payoff targets (HPTs).
- Smoke.
- Allocation of Copperhead target.

c. **METT-T Analysis.** METT-T is used as an analytical framework for planning combat operations. The following shows how METT-T can be used to accomplish a mission:

(1) **Mission.**

- (a) What is the intent of my battalion or brigade commander?
- (b) What is the purpose of my mission?
- (c) What are the tasks of my company? What am I expected to accomplish? (Both specified and implied tasks must be considered.)
- (d) How much time do I have? What times are critical-for example, start points, release points, and lines of departure?
- (e) Have I assigned the correct missions and tasks to my platoons?

(2) **Enemy.**

- (a) What is the enemy's composition and what are his abilities? (This information is needed to understand the enemy.)
- (b) What is the enemy's strength (weapons, supporting fires, special munitions, organization)?
- (c) What is the enemy's disposition? What avenues of approach would support his tactics (front, flank, mounted, dismounted, air)?
- (d) What tactics and formations will the enemy use in relation to my plans?

(3) **Terrain and weather.** (See FM 34-81-1 for more information about the effects of weather.)

- (a) What effect will the terrain have on my mission? (To answer this, the company commander analyzes the terrain based on OAKOC.)
 - O - Observation and fields of fire.
 - A - Avenues of approach.
 - K - Key terrain.
 - O - Obstacles.
 - C - Cover and concealment.

- (b) Will the weather hamper or enhance operation of my systems, units, or supporting units? What can I do about it?
- (c) Will the weather change the trafficability of the area?
- (d) How much space do I have? Is it adequate? How does it affect my company?
- (e) What is the effect of these factors on use of the obscurants and the employment of chemical weapons?

(4) **Troops.**

- (a) What type forces are available?
- (b) What is the strength of the available forces?
- (c) What are the abilities of my platoons?
- (d) What CS and CSS are available?

(5) **Time available.**

- (a) How much time do I have before the mission begins?
- (b) How much time will the enemy need to get here?
- (c) How much time will the company need to get there?
- (d) How long should the enemy stay in the engagement area?

d. **Antiarmor Support in the Offense.** Antiarmor companies use the same techniques for movement to contact, hasty attack, and deliberate attack (discussed here) as they do for other offensive operations such as exploitation and pursuit.

e. **Operations Security.** OPSEC includes all measures taken to maintain security and achieve tactical surprise. It includes countersurveillance, physical security, signal security, and information security. It also involves identifying, eliminating, or controlling tactical indicators that the enemy can use.

- (1) OPSEC is a command responsibility. All personnel must practice good OPSEC procedures before and during the battle. This requires high standards of discipline and training.
- (2) Enemy forces use a wide range of intelligence-gathering sources to learn the locations, abilities, and intentions of friendly units. These sources can include ground reconnaissance units, photo and signal intelligence, and HUMINT. OPSEC measures should be considered during the planning and conduct of each operation and after each after-action report (AAR).
- (3) The key to OPSEC is reducing electronic, visual, thermal, and operational signatures. For OPSEC to be effective, the company must see the enemy before he sees the company. Although the commander must depend on battalion for intelligence, he can include the following checklist in his SOP to avoid OPSEC violations:
 - (a) Use OPs to cover areas that are hard to observe.

- (c) Use defilade positions for cover and concealment.
 - (d) Enforce noise and light discipline to reduce possible detection of the company in day or night.
 - (e) Plan smoke and use it when necessary.
 - (f) When COMSEC devices are unavailable or nonoperational, send friendly locations relative to friendly graphic control measures or encode them using the current SOI. Send enemy locations by radio in the clear.
 - (g) Ensure radio transmissions are less than 15 seconds, with a break between transmissions.
 - (h) Use the SOI authentication tables. Platoons request authentication either when a change in the mission is received, when the authenticity of a transmission is in doubt, or when a net is opened or closed.
 - (i) Submit a (company) MIJI report when jamming, interference, or deception is detected.
- f. **Control Measures.** FM 101-5-1 defines control measures.

G-15. DEFENSIVE OPERATIONS

The commander must plan antiarmor tire in depth. In the defense, he may initially position antiarmor sections or platoons in one of two ways. He can position them in depth. Or, he can position them forward with task-force scouts or with the counterreconnaissance force, moving them to in-depth positions as the enemy closes. TOWs positioned forward establish antiarmor ambushes to destroy targets identified by the scouts or by the counterreconnaissance force. Establishing phase lines that can be identified in obscuration enables TOW gunners to fire within their engagement capability. Identifying far-half and near-half shots within the engagement area ensures minimal overkill in fire control.

- a. **Purpose.** The purpose of defensive operations is to defeat the enemy's attack and to gain the initiative. Defense is a temporary measure. It is conducted to identify or create enemy weaknesses that offer an early opportunity to change to the offense. Initially outnumbered, the defender uses maneuver first to blunt the attack. Then he concentrates combat power by counterattacking and by directing friendly strength against enemy weakness. Defensive operations destroy the enemy by achieving one or more of the following:
- (1) Causing an enemy attack to fail.
 - (2) Deceiving the enemy.
 - (3) Gaining time.
 - (4) Concentrating forces elsewhere.
 - (5) Controlling key terrain.

- (6) Wearing down enemy forces before offensive operations.
 - (7) Retaining terrain temporarily.
- b. **Planning.** Planning for defensive operations begins when the commander receives a warning order or OPORD. He formulates a plan for the defense that meets his requirements for the mission. He bases this plan on the factors of METT-T and on those developed in the estimate of the situation. Based on this analysis, the commander completes the estimate of the situation and formulates a concept of defense. He decides how to defeat the enemy, where to concentrate effort, and where to take risks. The commander must use every resource available to offset the attacker's numerical advantage, to identify dangerous threats, and to mass combat power against the enemy's weaknesses. The terrain provides natural obstacles and potential for cover, concealment, and movement; these influence how the commander designs the defense. Also, the commander must plan how to reinforce natural obstacles with man-made obstacles to enhance the strength of defensive positions and to protect maneuvering units.
- c. **METT-T Analysis.** The commander must quickly consider Mission, Enemy, Terrain, and own Troops. With the information available, the commander establishes a Time schedule by identifying actions (time-critical tasks) to prepare the company for the operation. Platoon leaders then make their schedules based on the commanders.
- (1) **Mission.** The first consideration when planning a defensive operation is the mission. It defines the area to be defended or the force to be defeated. The company commander must analyze the mission in terms of the higher commander's overall concept.
 - (2) **Enemy.** The enemy's doctrine, habits, equipment, and probable COAs must also be considered in planning the defense. Company commanders must look at themselves and their areas of operation through the enemy commander's eyes. They must then look for and counter vulnerabilities the enemy could exploit. In addition, they must identify probable enemy objectives and approaches to them. In a defense against an echeloned enemy, commanders must know how soon enemy follow-on forces can join the attack. If these follow-on forces can be delayed, the attack may be defeated in detail—one echelon at a time.
 - (3) **Terrain and weather.** The defender must exploit any aspect of the terrain that impairs enemy momentum or that makes massing or maneuvering enemy forces difficult. Defenders must engage the attacker where the terrain puts him at the greatest disadvantage. Controlling key terrain is vital to a successful defense. Some terrain may be so important to the defense that its loss would prove decisive. When terrain is a decisive factor, the leader makes it a focal point of his defense. Weather and visibility affect how defenders organize on the ground; commanders consider these effects as they analyze terrain. The defender uses man-made obstacles to improve the natural structure of terrain, to slow

or canalize enemy movement, and to protect friendly positions and maneuver. Commander must observe the terrain from the enemy perspective. This means they must be on the terrain to study proposed defensive areas and positions.

- (4) **Troops.** The commander also considers the nature of his force. Armor and mechanized forces can move on the battlefield even under artillery fire. Dismounted infantry can fight effectively in close terrain and in urban areas that limit mounted units. The commander also considers that his soldiers' mobility, protection, morale, and training help determine how they defend.
 - (a) **Indirect fire support.** Indirect fires are used to enhance direct fires and to disrupt or isolate the enemy. Specific indirect-fire munitions (smoke, DPICM, HE) can be used for their various effects on the enemy. They can be used to canalize him, destroy him, or prevent him from observing the defender. Indirect fire is flexible; properly planned and employed, it contributes greatly to a unit's ability to mass fires at the decisive place and time.
 - (b) **Mobility, countermobility, survivability.** Skillfully using engineer assets allows the defender to make the most of direct and indirect fires. Mobility operations allow reserve or counterattack forces to move to positions of advantage so they can exploit the success achieved by gaining and maintaining the initiative from the enemy. Countermobility operations canalize, slow, or break up enemy formations. This allows the defender to mass overwhelming firepower against the attacker. Survivability operations protect units from the effects of enemy firepower, thus conserving their fighting potential for use at the decisive time and place.
 - (5) **Time available.** The amount of time available to prepare is a crucial factor in organizing a defense. The defense is more effective when it has time to reconnoiter and occupy positions; to fortify the ground; to plan fires; to install obstacles; and to coordinate and rehearse maneuver, fires, and logistic support. Time is a critical element for the defender; it cannot be wasted. Small units must be able to defend with little preparation, but their leaders must recognize that strong defenses take time to organize and prepare.
- d. **Antiarmor Support in the Defense.** Antiarmor companies add long-range precision fires to the defense as part of the security force, as an element within the MBA and as support for counterattacking forces. Antiarmor platoons may also reinforce a unit whose mission is to prepare and defend a strongpoint. The following discusses how antiarmor companies support the defense:
- (1) **Security force.** Defending battalions deploy security forces forward of the forward edge of the battle area (FEBA) to provide early warning, to deny enemy observation of the MBA to assist rearward passage of a covering

torte, and to deceive and disorganize the enemy. The commander positions the security force where it can cover enemy avenues of approach into the defensive sector, that is, in OPs across the battalion front on suitable terrain. He positions antiarmor platoons with OPs that offer long-range fields of fire on high-speed enemy avenues of approach. As the enemy approaches, the antiarmor platoons use their standoff and engage armor at maximum range. Supporting field artillery and mortars engage at the same time with indirect fires to disrupt enemy formations and to force enemy crews to button up. These concerted fires degrade the enemy's ability to acquire targets. These fires also help reduce enemy pressure on any covering force units still in contact, which eases the unit's passage to the rear. As the enemy closes, the security force withdraws by alternate or successive bounds to subsequent positions and continues to engage. The security force may continue this process through the FEBA and into the battalion defensive area to further deceive the enemy as to the defensive scheme. The security force may disengage under covering fires from the battalion and move to positions in depth, or it may assume another role in the battalion defense.

- (2) **Main battle area.** Within the MBA the battalion commander organizes and positions his forces based on his METT-T analysis. He normally deploys the antiarmor company in mass, but he may cross-attach one or two TOW platoons to strengthen his antiarmor defenses.
 - (a) The commander positions the antiarmor company and platoons to cover avenues of approach that afford long-range fields of fire. He employs tanks where fields of fire are shorter and more restricted. He should position antiarmor platoons where they can use their standoff range (except against ATGMs). To enable tanks and other antitank systems to achieve this standoff and to mass fires in a particular engagement area, he positions antiarmor platoons in depth or on the flanks of other defending companies. When he does this, he must also consider positioning infantry near the TOW systems to provide security against a ground attack. To achieve depth, the battalion commander must initially position his platoons throughout the depth of the sector, displace them from forward positions, use alternate and supplementary positions, mass TOW fires with tank or other antitank systems, and maintain standoff by repositioning to firing positions that allow the TOWs to engage tanks beyond the tanks' effective ranges (Figure G-9).

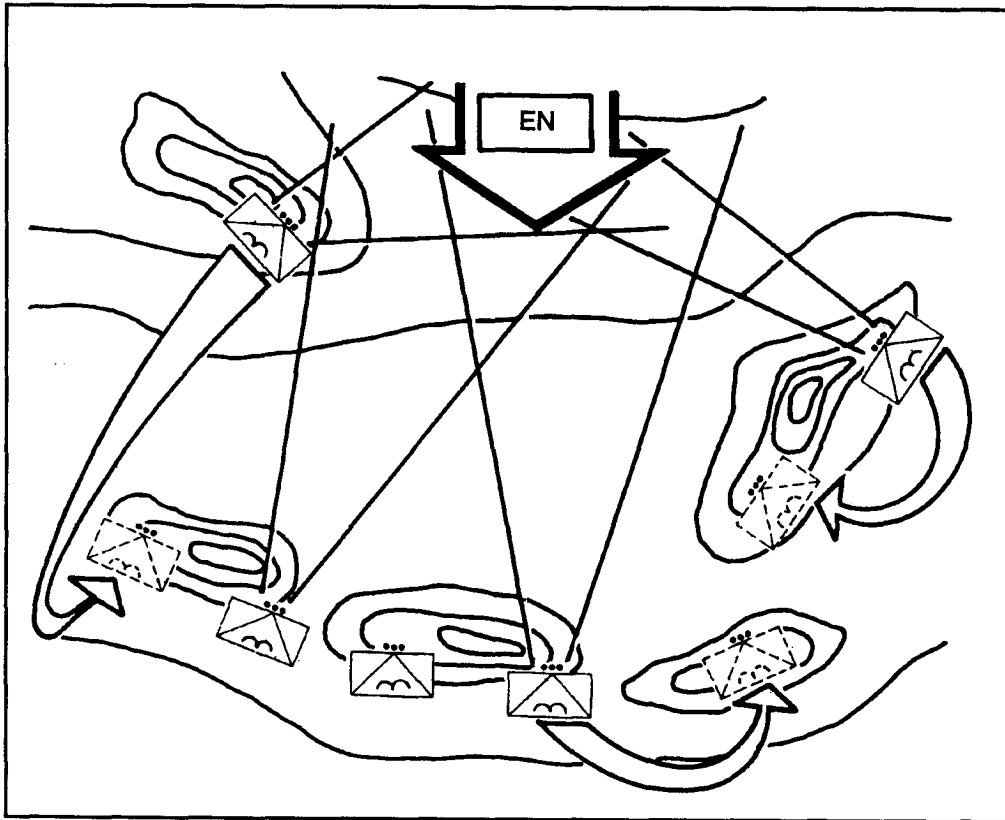

Figure G-9. Massing of fires using in-depth positions.

- (b) Skillfully integrating fires and obstacles prevents the enemy from easily engaging friendly antiarmor systems and slows and canalizes his advance. This increases TOW engagement time, which in turn increases the probability of achieving a target hit.
- (c) When terrain or other conditions dictate that antiarmor units locate with tanks or infantry (Figure G-10, page G-30), the commander selects positions that use each system's range capability.
- (d) Whether the commander locates them separately or along with tanks and infantry, antiarmor units always select multiple firing positions to cover primary and secondary sectors of fire. Clearing antiarmor fields of fire must be a priority task for engineers in preparing defensive positions. When standoff exists, TOW squads may engage two or more targets before they change firing positions. When ranges are 2,000 meters or less, the commander should displace the TOW squads to enable them to regain their standoff, otherwise, he should have them change positions after each engagement.

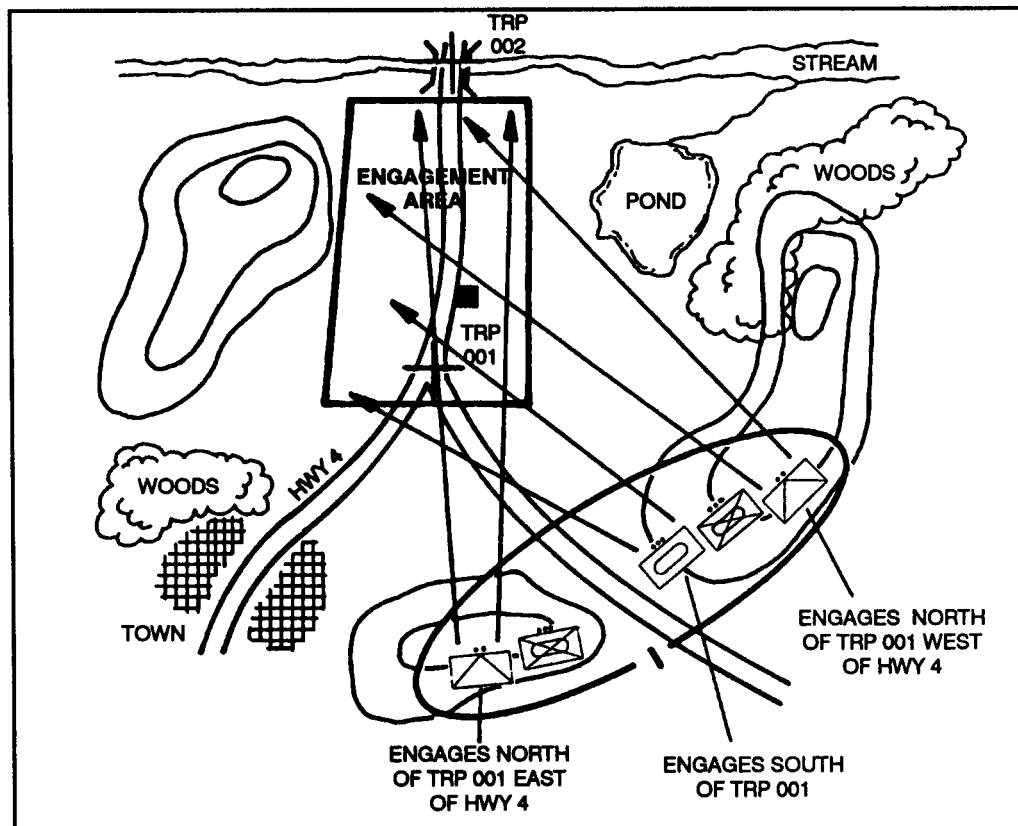

Figure G-10. Massing of fires from a single position.

(e) The control of and order of displacement for antiarmor units are special considerations. The vulnerabilities of ITVs and wheeled-vehicle mounted TOW systems can be reduced if the commander carefully plans and controls their displacement. The following factors affect displacement:

- Commander's intent.
- Enemy's closing speed.
- Obstacles affecting enemy movement.
- Distance to subsequent positions.
- Covered and concealed routes to subsequent positions.
- Availability of armor and infantry overwatch units.
- Visibility.

- (f) In daylight, the commander normally has TOW systems displace first, followed by infantry, then tanks. During limited visibility, the commander may displace tanks before infantry, but he normally displaces antiarmor units first. A thorough reconnaissance of routes and subsequent positions reduces confusion and movement time.
 - (g) In limited visibility conditions, the TOW nightsight enables the gunner to engage targets when visibility is degraded. However, environmental factors reduce target engagement distances.
 - (h) In most cases, the commander employs TOW systems mounted. This permits rapid movement and reduces their vulnerability to enemy direct and indirect fires. In some cases, the commander should employ them dismounted such as to defend a built-up area or to defend in built-up terrain. In these situations, the commander tries to use vehicles to transport the TOW systems to their firing positions and to resupply ammunition.
- (3) **Counterattack** The commander conducts counterattacks to disrupt and destroy an attacking force. Antiarmor units take part in the counterattack just as they would in a hasty or deliberate attack.
- e. **Control Measures.** Control measures help the leader explain his concept and the execution of the defense. He uses control measures to position units, to control movements, to distribute and control fires, and to synchronize combined arms. Several control measures, (sector of fire, TRPs, engagement area, position, strongpoint, boundary, contact point, and checkpoints) are discussed in FM 101-5-1. The following also apply:
- (1) **Disengagement criteria.** These describe a predetermined event that must occur on the battlefield before a soldier, weapon, or unit can move to a subsequent position.
 - (2) **Engagement criteria.** These describe a predetermined event that must occur on the battlefield before a soldier, weapon, or unit can begin firing.

G-16. RETROGRADE OPERATIONS

Retrograde operations, which are organized movements away from the enemy or to the rear, preserve the integrity of the force until the offense can be resumed. The three types of retrograde operations are *delay*, *withdrawal*, and *retirement*. Antiarmor elements help a battalion faced with a tank or motorized threat to conduct a delay or withdrawal. This paragraph discusses only those two operations. Delay, withdrawal, and retirement operations are discussed in detail in FM 7-20. The purpose of retrograde operations is to improve an operational or tactical situation or to prevent a worse one from developing.

- a. **Delay.** A delay is an operation in which space is traded for time. It differs from the defense; a delaying unit is seldom required to become decisively engaged, to hold terrain, or to destroy the enemy force. An exception occurs

when a delaying force is told to hold the enemy forward of a specified line for a given time, or to hold him there until a particular event has occurred. When given this mission, a delaying force is expected to achieve the required delay even if it must become decisively engaged to do so.

- (1) **Concept.** The concept of the delay is to fight the enemy with enough force to make him expend time deploying and maneuvering to close with the delaying force. The delaying force defends the delay position only until the enemy's actions threaten decisive engagement (except as described previously). The delaying force then disengages, moves to a subsequent position, and repeats the process.
- (2) **Task organization.** The battalion commander allocates antiarmor platoons to the security force, the delaying companies, and the reserve, based partly on his analysis of METT-T, but more importantly on the enemy avenues of approach. He can attach antiarmor platoons to delaying companies or to company teams covering armor avenues of approach with long-range fields of fire. To create another delaying company, he can cross-attach the antiarmor company with infantry and tanks. The antiarmor company may also provide the nucleus for a mobile reserve. The battalion commander may use this reserve to reinforce the tires of forward elements, to assist the disengagement, to cover repositioning forward elements, and to provide depth along the most threatening avenues of approach.
- (3) **Employment.** A company delay may be conducted in two ways: delay in sector or delay forward of a line until a specified time or event.
 - (a) *Delay in sector* is the delay mission that allows the most freedom in using terrain. Usually with this mission, no requirement exists to hold key or decisive terrain. Delay from sector may be conducted from successive or alternate positions. Successive positions are used when a wide sector or avenue of approach must be covered and when all or most of the forces must be deployed forward to cover the area. Successive positions are also used when the terrain prevents depth in the delay. The company fights the battle from phase line to phase line, front to rear. The platoons disengage separately from one phase line or battle position to the next, while remaining platoons provide overwatch. The situation may force the entire company team to disengage at the same time. If enemy forces move more quickly than expected, the possibility of becoming decisively engaged increases. With a delay from sector, bounding within platoons is necessary when the terrain restricts the platoons' ability to provide mutual security. Alternate positions are used when the area is deep and narrow enough to be covered by one or two platoons. Alternate positions allow for more depth and security. The leapfrog nature of this maneuver prevents the forces from firing everything they have at the enemy all at once. In a delay from alternate positions, platoons are moving and fighting at the same time, so this method is more difficult to control

- than a delay from sueassive positions. However, because other platoons are fighting and providing security, the delay from alternate positions allows squads more time to move to their next positions.
- (b) *Delay for a specified time* is the delay mission that entails the greatest risk. This mission involves preventing enemy forces from reaching a certain area before a specified time or event, regardless of the cost. The task force commander restricts the crossing of a certain phase line or limits the maneuver from battle position to battle position, based on a specified time or event.
- (4) **Rehearsal.** The commander rehearses the delay mission. He can drive through the sector and envision it from the enemy's position. From there, the commander locates dead spaces or a mobility corridor that may have been overlooked. He also looks for weaknesses in his own positions or camouflage. The commander then assumes the role of the enemy to ensure the platoons can exeecute the direct fire plan. As he approaches, the platoons practice engaging at the appropriate phase lines and moving to alternate positions. When the commander reaches the phase line where each platoon is to disengage, that platoon displaces. The commander ensures they do so in the designated order and that the platoon covering the move reorients their weapons to cover the company sector. The commander ensures each vehicle uses the proper lanes to displace. He changes the movement routes of any vehicles that are exposed as they conduct the move. The commander approaches the position at a speed consistent with enemy doctrine to see whether the enemy will be able to engage or close with the delaying forces as they displace. He follows through his rehearsal to the final positions and adjusts his plan based on the results. He reviews the rehearsal with his XO and ensures his second in command can take over the command of the operation if needed.
- (5) **Command and control.** The commander must position himself to see the battle and assess both the enemy situation and the effectiveness of the delay plan. Because the enemy will seek a gap in the delaying forces, the commander must plan to maintain flank coordination throughout the operation. He must also assess whether the defenses are strong enough to make the enemy deploy. The commander must plan a series of redundant signals for displacing the platoons to their next set of battle positions.
- (6) **Maneuver.** As the enemy enters the engagement area and passes the phase line, the company engages with massed direct and indirect fires. These fires combine with a well-placed obstacle system to inflict severe casualties on the enemy. The platoons fire at the same sustained rate as they would in a battle position defense, moving to alternate positions to further exploit enemy weakness. If the enemy reaches the phase line where the platoons are to disengage or meets other disengagement criteria, the company begins displacing to subsequent positions.

Disengagement and withdrawal are the most dangerous parts of the operation. The commander must begin displacing before the enemy can close with the company. If he waits too long, the enemy could decisively engage the delaying force. Massed artillery fires and smoke screens aid in the disengagement. During the displacement, covering platoons shift their direct fires to cover the majority of the engagement area. Once the other platoons are out of danger, they overwatch while the covering platoon displaces. Along the egress route to the next defensive positions, artillery fire and reserve demolitions combine with overmatching fires to reinforce the delaying force's ability to avoid decisive engagement. Once in position, the delaying force repeats the process in an attempt to cause the enemy to deploy as often as possible and to destroy as much enemy equipment as possible.

- b. **Withdrawal.** Withdrawal is an operation in which all or part of a force frees itself from contact with the enemy to perform a new mission. Units should not withdraw while under heavy enemy pressure.
- (1) **Concept.** Withdrawing units move secretly to deceive the enemy. Withdrawing units under enemy pressure initially conduct a delay. This enables them to gain a mobility advantage and to free nonessential combat, CS, and CSS units. To deceive the enemy and to protect the withdrawal of other units, some elements remain in contact. Such an element is referred to as a detachment left in contact (DLIC). The battalion XO normally commands a battalion DLIC, which may comprise either parts of each committed company team under control of the company XO, or of one or more whole companies or teams.
 - (2) **Task organization.** The size and composition of the DLIC depends on the width of the front, the forces available, the amount of enemy contact, and the period of delay required. Ideally, a DLIC's main function is to deceive rather than fight the enemy however, it must have sufficient combat power to stall him until the withdrawal has been completed.
 - (3) **Employment.** Antiarmor units can remain as part of a DLIC against an armored threat. They help by placing massed fires on enemy high-speed avenues of approach. The antiarmor company reinforced with infantry may form the nucleus of the battalion DLIC. Tank units should also be included due to the greater protection, mobility, and firepower they offer. Antiarmor sections, platoons, and companies fight as part of the DLIC the same as in the delay.
 - (4) **Command and control.** The company commander positions himself where he can watch the withdrawal of the main body and of the DLIC. Because the DLIC's combat power is limited, the commander ensures that it remains forward no longer than it must. If a rearward passage of lines must be conducted at the end of a withdrawal, the commander reports when all company elements have completed the passage, hands

the battle over to the stationary force, then joins his own force to prepare for its new mission.

- (5) **Maneuver.** The entire company must ensure that all activities appear normal while it prepares to withdraw. All normal defensive activities, including radio transmissions, eating schedules, and maintenance, must appear to be conducted IAW the current mission. Though vehicle movement may be required to position the DLIC and to prepare for the company's movement to the rear, it must be conducted gradually and quietly.

G-17. SPECIAL MISSIONS

After the battalion commander determines his task organization, he can employ the antiarmor company as a reaction force in support of rear operations, as a higher unit reserve, or as a security/counterreconnaissance force. Depending on METT-T, TOW HMMWVs equipped with HIMS to mount MK 19s and M2 .50 caliber heavy barrel machine guns can increase the combat power of a TOW company.

- a. **Rear Operations.** These include any operations in rear areas that protect units, lines of communications, installations, and facilities from enemy attack or sabotage. Though CS and CSS units operating in the rear set up their own defenses, they may require the greater protection of combat forces if the enemy breaks through or launches special operations into the rear area. During these rear operations, the antiarmor company acts as a reaction force. It must be prepared to respond within a specific amount of time. The company SOP should address these readiness conditions. Dispersion and camouflage must be weighed against responsiveness. This special mission requires the same amount of preparation as any other mission. The company must reconnoiter its area of responsibility and organize to best accomplish its attack. It must set up a CP to provide the best possible command and control. The rear area, base cluster, base defense operations centers, installation commanders, supported CSS commanders, and the military police must coordinate plans for defending rear area installations and activities. As the reaction force, the antiarmor company provides security, destroys known enemy forces in the area, and provides primary combat power to the rear area.
- b. **Role of the Reserve.** The firepower and mobility of the TOW company or team enable it to act as a reserve. Reserves are concerned with rear operations, counterattack, and relief operations. At battalion level, reserve forces are those that are neither engaged nor assigned as a dedicated reserve. Dedicated reserve companies are those that must be ready for action at any time.
- c. **Security Operations.** Counterreconnaissance, a subtask of security, prevents the enemy from detecting and observing a force, area, or place through

visual, electronic, sonic, or other means. The security or counterreconnaissance force prevents the main body from being observed or surprised by an enemy attack or reconnaissance probe. Security operations are conducted forward, to the flanks, or to the rear of the battalion. The company assigned a security operation can screen the battalion from great distances. Ideally, the antiarmor commander can coordinate counterreconnaissance. By placing scouts, tanks, and TOWs under the antiarmor commander's control, the battalion commander obtains a unified counterreconnaissance operation. He uses scouts to identify the composition and direction of movement of the enemy reconnaissance. Then he can use the tank and TOW assets to fix, fight, or delay the enemy. This gives the battalion the time and space to position forces to fight the enemy. The success of this task requires habitual relationships and extensive training. The battalion commander should also consider what CSS assets are available to support the mission.

G-18. TACTICAL ROAD MARCH

The antiarmor company often moves long distances by road march into positions for a future operation.

- a. Success of a road march depends on a good company SOP and detailed planning. Certain tasks are standard in any road march and should be included in the SOP. These tasks areas follows:
 - (1) List all vehicles by march serial and bumper number.
 - (2) Designate a marshaling or staging area to organize the column and conduct final inspection and briefings.
 - (3) Lay out the route to include start point, checkpoint(s), and release point. Include critical areas, defiles, choke points, rest and maintenance stops, and other areas of danger or potential difficulty.
 - (4) Organize, brief, and dispatch the quartering or reconnaissance party. Have it drop off guides or mark the route for the main body.
 - (5) Assign the best map reader to the lead vehicle.
 - (6) Thoroughly brief everyone in the company.
- b. The main road march techniques are open and close column.
 - (1) **Open column.** This technique is used for daylight marches. It can also be used at night with blackout lights or thermal-vision equipment. Though the distance between vehicles varies, depending on road conditions and weather, it is normally 50 to 100 meters.
 - (2) **Close column.** This technique is used for marches in darkness or limited visibility. The distance between vehicles is about 25 meters, or near enough that vehicle drivers can see the blackout markers on the vehicles directly in front of them.

G-19. ASSEMBLY AREA OPERATIONS

The company uses an assembly area to prepare for future operations. Though this area is not a battle position, it should be located on easily defensible terrain and should be planned like a defensive position.

- a. **Concept.** A well-planned assembly area offers concealment, good routes in and out, security from ground and air attack and observation, and good drainage. Wheeled and tracked vehicles must be able to move with ease, even in a wet environment.
- b. **Quartering Party.** A quartering party includes the company XO or first sergeant, a security element (if the tactical situation requires), and one or two representatives from each platoon. The security element should consist of two combat vehicles from the same platoon. Each platoon should have an NCO (preferably platoon or section sergeant) and a representative soldier. The quartering party must—
 - (1) Reconnoiter the area for enemy forces, route condition, adjacent terrain, and NBC contamination. If the area is unsatisfactory, the party contacts the company commander and requests relocation (FM 5-36).
 - (2) Organize the area based on the commander's guidance by designating platoon areas, the command post, and the trains area.
 - (3) Mark vehicle locations and guide vehicles into locations.
- c. **Unit Actions.** The company should occupy part of a task force assembly area, but rarely should the company be assigned a separate area. TOWs should be positioned within the assembly area to cover mounted avenues of approach, and the infantry should secure the dismounted approaches. In the assembly area, the commander should issue his orders, and the company should—
 - (1) Conduct maintenance (weapons, vehicles, and soldiers).
 - (2) Resupply, refuel, and rearm.
 - (3) Rehearse the upcoming operation.
 - (4) Verify weapon system status by conducting system checkout procedures and preventive maintenance checks. If the location allows, it should also test-fire the weapon system.
 - (5) Eat and rest.

Section IV. FIRE CONTROL

Controlling antiarmor fires against an attacking armored force is vital. This section discusses some of the fire control techniques available to the company commander.

G-20. PRINCIPLES OF FIRE CONTROL

The commander seldom has time to give his subordinates detailed instructions. He must establish a reliable SOP for distribution of fires. Two factors are critical to fire control during the first few minutes of battle the procedures contained in the SOP and the initiative of subordinate leaders. After that, leaders can redistribute fires when they have time. The following specific principles guide fire control:

- a. **Cover Targets.** Fires from antiarmor weapons should be distributed so that they cover all targets. Proper distribution saves ammunition and increases the number of kills antiarmor weapons can achieve.
- b. **Avoid Target Overkill.** The company cannot afford to engage one target with more than one weapon. They should strive for one-on-one engagements and one-shot kills.
- c. **Fire First, Fast.** Accuracy is important in battle, but firing accurately *and* first are more important. When opponents with similar capabilities fight, the side that fires has better odds. When friendly units see the enemy but are not seen, they can choose the best moment to fire. Placing fire in the enemy's area lessens his effectiveness and allows friendly weapons time to adjust. Antiarmor weapons should engage the enemy rapidly and continuously.
- d. **Destroy the Most Dangerous Target First.** Target danger varies with range, terrain, and type of target—for example, at a range of 600 meters, tanks may present a greater threat than ATGMs. If antiarmor weapons cannot engage all targets, they should suppress some and destroy the rest of those they can engage.
- e. **Maintain Basic Loads as Long as Possible.** Ammunition is easier to use than to resupply. Without proper fire discipline and coordination, a unit can use its entire basic load in one engagement, thus rendering itself ineffective for later ones. The unit should check its ammunition supply constantly. SOP should establish the level at which each unit must be resupplied. However, resupply should be frequent—no unit should drop below the level set by the SOP except for an emergency or to protect itself.

G-21. COORDINATION OF COMPANY FIRES

The antiarmor company commander coordinates the fires of his platoons with other fires based on the battalion plan. To do this, he gives his platoon leaders the following information:

- a. **Platoon Positions on the Battlefield.** The commander selects platoon positions after he assigns engagement areas or sectors of fire to his platoons. He gives each platoon its primary position and, in some cases, its subsequent positions. He chooses initial positions to allow platoons to integrate their fires. He chooses subsequent positions where, if enemy actions drive them from their initial positions, the platoons can continue firing into an engagement area. He uses subsequent positions to reposition platoons to fire into different engagement areas or sectors.
- b. **Primary Sector of Fire.** The commander assigns each platoon a primary sector of fire to cover from its primary position. This ensures mutual support (overlapping fires) between adjacent platoons and reduces target overkill.
- c. **Secondary Sector of Fire.** The commander assigns each platoon a secondary sector of fire to reinforce the fires of another platoon. On order, the platoon shifts fire to its secondary sector. This occurs either if the primary sector contains no targets or if a platoon in another sector must move and requires covering fire.
- d. **Engagement Areas.** The commander uses engagement areas to mass the fires of his platoons into one target area. The company commander may use target reference points (TRPs) to divide engagement areas into sectors of fire.
- e. **Target Reference Points.** The commander designates TRPs to identify targets and distribute the fires of his platoons. Since platoons engage from different directions, the commander uses compass points (rather than "left" or "right") to give directions relative to TRPs.

G-22. ENGAGEMENT PRIORITIES

Armor formations present varied targets: tanks, APCs, air defense weapons, or artillery, for example. To ensure platoons rapidly and effectively distribute their fires, the antiarmor company commander can assign each platoon a particular type of target to engage first.

Section V. PROCEDURES

This section discusses procedures, which are standardized actions conducted IAW a company's SOP. The antiarmor company commander must first establish security, then he can establish his company's priority of work.

G-23. SECURITY

The commander should establish observation posts and assign local patrols to search for enemy stay-behind forces, sensors, mines, or booby traps. Patrol teams should also reconnoiter any terrain that enemy reconnaissance units could use to call for and adjust indirect fire or to direct enemy maneuver units. The patrol teams can protect emplaced obstacles, cover dead space between units, or cover dismounted avenues of approach. To establish security, the commander must—

- a. Emplace PEWS in dead space or between units, to complement the efforts of patrols (when units are augmented by an infantry platoon).
- b. Position chemical detection alarms upwind from the platoon's position. Perform periodic checks and maintenance on the alarms; move them if wind direction changes.
- c. Position key weapon systems. (The platoon leader positions the ITVs.)

G-24. PRIORITY OF WORK

The commander should establish a priority of work to help his company use time efficiently. Though this should already be part of the SOP, he can modify it to fit the mission. In most situations, the priority of work is as follows:

- Establish security (as previously discussed).
- Position weapon systems.
- Clear fields of fire.
- Prepare range cards.
- Prepare firing positions. (Leaders inspect positions in stages as they are constructed.)
- Emplace obstacles.
- Establish local communications.
- Stockpile ammunition, food, and water.
- Perform maintenance rest.
- Coordinate between adjacent units.

G-25. POSITIONING OF TOW VEHICLES

Enemy vehicles are most heavily armored in the 60-degree arc to the front, so friendly antiarmor units must try to engage each enemy vehicle from its flank or rear. Though the angle of engagement is important, targets normally are engaged when they appear. Therefore, leaders must position TOW vehicles where flank engagements are most likely to occur. This means fighting positions must be placed to the flank of enemy avenues of approach. Battlefield dust, smoke, fog, and darkness normally limit observation and fields of fire. When engagement ranges are reduced, flanking fires, obstacles, mutual support with infantry, and covered and concealed positions increase in importance. Due to battlefield obscuration, weapons must be positioned as they would be to fight during limited visibility, or they must be positioned where they can quickly move to limited visibility positions. The following positions may be used by TOWs:

- a. **Defilade Positions.** These are classified as either turret defilade or hull defilade positions. A turret defilade position uses terrain to mask the ITV; only the 3-power acquisition sight is exposed to the enemy. A hull defilade position uses terrain to mask the hull of the ITV; the ITV turret is revealed only as much as necessary to engage targets.
- b. **Flank Positions with Restricted Fields of Fire.** Leaders must position TOW vehicles on the flanks of expected enemy avenues of approach. In restrictive terrain, this provides opportunities to engage the enemy from narrow, sectors of fire that protect the TOW vehicles from overmatching enemy fire. They are only vulnerable to their current targets, and as soon as these are destroyed, the TOW vehicles move quickly to new firing positions (Figure G-11).

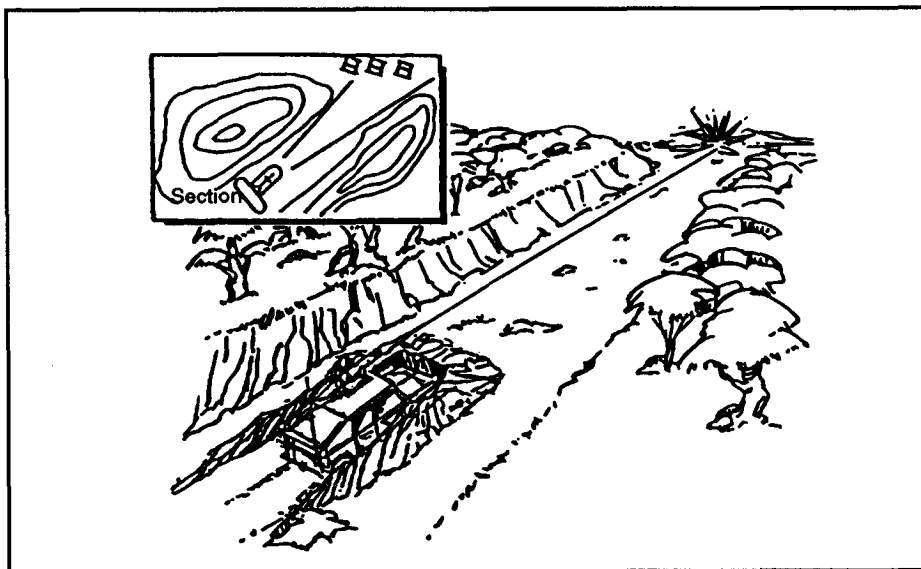

Figure G-11. Flank positions with restricted fields of fire.

- c. **Hide Positions.** Hide positions are where a soldier, vehicle, or unit can remain completely unexposed to observation or direct fire. TOW vehicles hide where they can observe part of the enemy's expected avenue of approach. They hide behind small terrain features rather than behind constructed berms, which must be more than 20 feet thick to be effective. Also, berms allow the attacker to more easily spot a defender's hide position. Backdrops that catch the eye should be avoided—for example, an ITV or BFV positioned near a large boulder or other prominent terrain feature will usually be detected. Hide positions must be chosen so that vehicles moving into and out of them are covered. The availability of such covered routes and the quality of the hide positions as firing positions share equal importance. To avoid creating diesel or dust signatures, weapons must be moved carefully into hide positions. Primary and alternate TOW positions should be at least 75 meters apart. Also, the greater the dispersion (in width and in depth) between them, the lower the chance that both will be suppressed or that the detection of one will give the other away. Just as it would from other positions, the TOW engages an enemy vehicle as soon as it appears. To engage a different part of the enemy's formation, the TOW vehicle must move around the terrain feature (Figure G-12). Using such limited fields of fire can be considered a fire control measure, because it also limits multiple engagements of the same target.

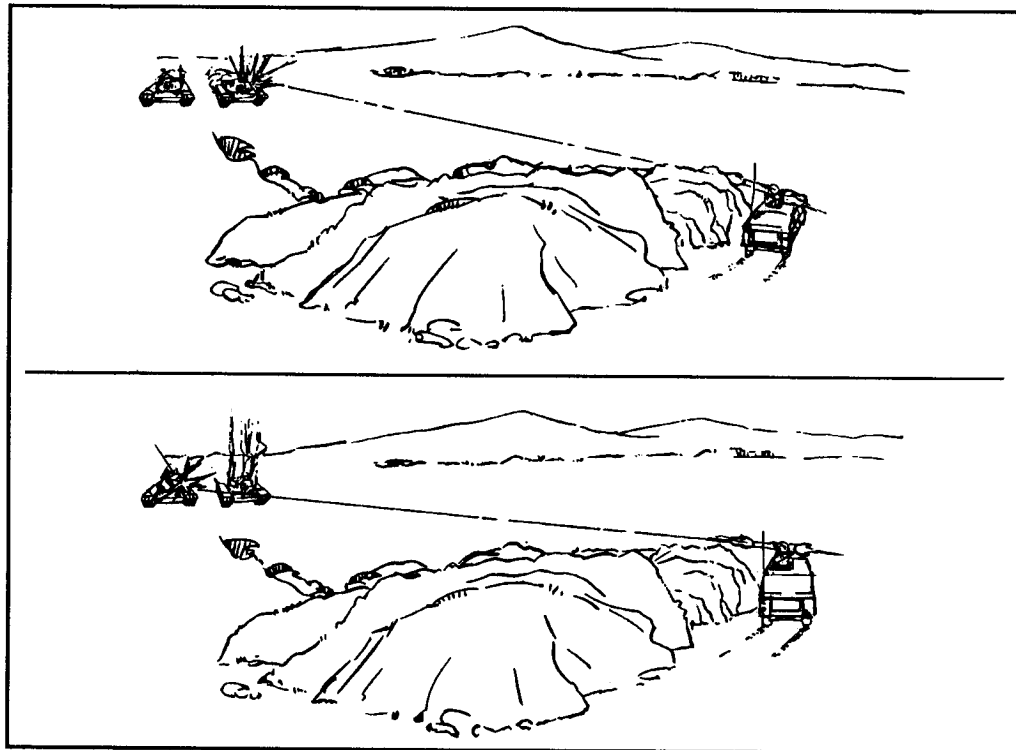

Figure G-12. Hidden position with smaller fields of fire.

G-26. TYPES OF TOW MISSILES

Several models of TOW missile have been fielded since its development. This paragraph discusses the differences between them. Some have a maximum range of 3,000 meters; others have a maximum range of 3,750 meters. Many of the later models have an expendable probe. Figure G-13 lists the different TOW missiles by type, designation, maximum range, and warhead.

TYPE	HEAT	INERT PRACTICE	MAXIMUM FLIGHT RANGE (METERS)	WARHEAD	COMMENTS
Basic TOW	BGM 71A	BTM 71A	3,000	5-inch unitary	
Basic TOW	BGM 71A-1	BTM 71A-1	3,000	5-inch unitary	
Basic TOW	BGM 71A-2	BTM 71A-2	3,750	5-inch unitary	*
Basic TOW	BGM 71A-3	BTM 71A-3	3,000	5-inch unitary	**
Improved TOW	BGM 71C	None	3,750	5-inch unitary with probe	
Improved TOW	BGM 71C-1	None	3,750	5-inch unitary with probe	
TOW 2	BGM 71D	None	3,750	6-inch full-caliber with probe	***
TOW 2A	BGM 71E	None	3,750	6-inch tandem with probe tip charge	** ***
TOW 2B	BGM 71F	None	3,750	Flyover, shoot-down, top attack	
<p>* The missile ordnance inhibit circuit (MOIC) prevents delayed-flight motor ignition, which causes an uncontrolled missile.</p> <p>** This denotes ECM-resistant when fired through a TOW 2 launcher or subsystem.</p> <p>*** The probe tip charge penetrates explosive reactive-armor boxes, allowing the main 6-inch warhead to penetrate the basic hull armor.</p> <p>TOW 2-series launchers should be used. The TOW 2-series missile can only be fired from the TOW 1-series launcher at a height of 6 to 9 feet from the ground.</p>					

Figure G-13. Fielded TOW missile types.

- a. **Characteristics.** The TOW missile can destroy targets at a minimum range of 65 meters and a maximum range of 3,750 meters. Five types of TOW missiles are as follows:
- (1) **BGM-71C.** The I-TOW, an improved TOW missile, has a 5-inch unitary warhead. Its expendable probe provides detonation prior to warhead impact, which increases penetration.
 - (2) **BGM-71D.** The TOW 2 missile has a 6-inch full-caliber warhead. It also has an expendable probe to enhance penetration of armor, including applique armor.

- (3) **BGM-71E.** The TOW 2A has all the capabilities of the TOW 2 missile. However, an explosive charge in the tip of the probe detonates reactive armor, allowing the main warhead to penetrate a target.
 - (4) **BGM-71F.** The TOW 2B provides a flyover, shoot-down (top-attack) capability that allows the missile to penetrate the most vulnerable part of an armored vehicle—the top of the turret. The minimum-effective range of this missile is 200 meters.
 - (5) **BTM-71A.** The basic practice TOW has an inert warhead and is the standard training round.
- b. **Enemy Armored Protection.** Flank shots increase the probability of a single-shot kill and reduce the chance of detection or engagement by armor. Figure G-14 recommends missiles that should be used based on the type of threat, if METT-T conditions allow.

VEHICLE-TYPE TARGETS	TOW MISSILE SELECTION PRIORITY			
	FIRST	SECOND	THIRD	FOURTH
Tanks with applique armor	TOW 2	TOW 2A	TOW 2B	I-TOW
Tanks with explosive reactive armor	TOW 2B	TOW 2A	TOW 2	I-TOW
Tanks without applique or reactive armor	TOW 2	TOW 2A	TOW 2B	I-TOW
Lightly armored personnel carriers	I-TOW	TOW 2	TOW 2A	TOW 2B
Lightly armored wheeled vehicles	I-TOW	TOW 2	TOW 2A	TOW 2B
Antiaircraft vehicles	I-TOW	TOW 2	TOW 2A	TOW 2B
Armored vehicles in hull defilade position	TOW 2B	TOW 2A	TOW 2	I-TOW
Bunkers or fortifications	I-TOW	TOW 2	TOW 2A	—

Figure G-14. Missile selection.

- c. **Limitations.** FM 23-34 discusses the following firing limitations in detail:
- Firing over water.
 - Firing over electrical lines.
 - Firing in windy conditions.
 - Firing through smoke and area fires.
 - Firing from bunkers and buildings.
 - Clearance requirements.

Section VI. COMBAT SUPPORT

This section discusses how CS enhances and multiplies the effects of the antiarmor company's combat power. CS assets include combat engineers, intelligence (including reconnaissance), air defense, and fire support (mortars, field artillery, Army aviation, and tactical air).

G-27. ENGINEER SUPPORT

Engineer units provide support to the antiarmor company. The task force commander assigns their command or support relationships (FM 5-100). Combat engineers have the skills and equipment needed to enhance friendly mobility and survivability, to counter the mobility of enemy forces, and to sustain the force. Combat engineers provide three specific categories of support:

- a. **Mobility Support.** Combat engineers seek to improve movement of the forces and of critical supplies by reducing or eliminating the effects of enemy obstacles. (FMs 71-1 and 5-101 discuss methods of reducing obstacles.)
- b. **Countermobility Support.** Combat engineers construct new obstacles and reinforce existing (natural or man-made) obstacles to TURN, FIX, BLOCK, and DISRUPT the enemy. Obstacles increase the time for tracking targets and increase the effectiveness of direct-fire and indirect-fire weapon systems. (FMs 71-1 and 5-102 provide information on constructing obstacles.)
- c. **Survivability Support.** Combat engineers construct protective positions, including hull defilade and dug-in positions and overhead protection, to reduce the effectiveness of enemy weapons. (FM 5-103 provides detailed information on survivability planning.)

G-28. INTELLIGENCE AND RECONNAISSANCE SUPPORT

Most of the information about the enemy comes from S2 intelligence reports, scout platoon reports, and personal observations. Other information about the enemy and area of operations is available from adjacent and supporting units. The battalion S2 provides information about the enemy, terrain, and weather. The company commander is the antiarmor company intelligence officer. He seeks information about the enemy, terrain, and weather from all available sources.

G-29. AIR DEFENSE SUPPORT

Enemy air forces with attack helicopters and high-performance (jet) aircraft may gain local air superiority and pose a danger to US ground units. An antiarmor company with no air defense artillery (ADA) system must defend itself against an air attack. It may take active or passive measures to do so.

- a. **Active Measures.** Company SOP designates soldiers or vehicles to watch for enemy aircraft in assigned sectors. To alert their unit, observers use flag signals, arm-and-hand signals, or audible signals. Enemy aircraft normally fly low and often fly down valleys. Enemy helicopters can appear from behind hill masses and engage at long ranges. If an enemy aircraft attacks, friendly units return fire. However, unless the aircraft is attacking the company, the antiarmor company should withhold fire and use passive defensive measures. (FM 44-8 provides more information about active air defense measures.)
- b. **Passive Measures.** An enemy pilot must see a target to engage it. Friendly units use cover and concealment to degrade the enemy's ability to acquire them as targets. (FM 5-20 provides more information on camouflage; FM 44-8 provides more information on passive air defense measures.) The following signatures identify friendly positions to enemy airmen:
 - Wheel or track marks, especially if they are obviously fresh.
 - Reflective surfaces such as windshields, headlights, goggles, map cases, field glasses, and sunglasses.
 - Smoke, exhaust plumes, dust, lights, and contrasting colors.
 - Movement.
 - Freshly exposed dirt around a fighting position.

G-30. FIRE SUPPORT

Fire support is the collective and coordinated use of indirect-fire weapons and armed aircraft in support of a tactical plan. Fire support sources include mortars, field artillery cannons and multiple-launch rocket systems (MLRS), Army aviation, CAS, and NGF. These means should be used to support the scheme of maneuver and mass firepower as well as to delay, disrupt, or destroy enemy forces.

- a. The commander must know what the FA and mortars can do. Also, he must know the fire support system and be able to plan and use indirect fires as effectively as he can the company's organic weapons. He must also direct the company's movement. Company and battalion fire support officers are available to advise the commander on the use of fire support, including mortars, FA, Army aviation, CAS, and (if available) NGF.

- b. Fire support destroys, neutralizes, and suppresses enemy weapons, formations, or facilities. Smoke obscures the enemy's vision, degrading the effectiveness of his direct-fire and indirect-fire weapons. High-explosive ammunition and dual-purpose improved conventional munitions (DPICM) cause enemy tanks and other armored vehicles to button up and slow down. This reduces the enemy's observation, flexibility, momentum, and ability to command and control. A technique is to mix smoke and HE effects in a target group. In the defense, the antiarmor company should fire mixed munitions at and beyond the phase line to disorient the enemy and to allow TOW gunners to engage Threat vehicles within the designated engagement area. (FM 7-90 provides additional information on the mortar platoon; FMs 6-20 to 6-20-40 and TC 6-71 provide additional information on fire support planning.)

* APPENDIX H

FRATRICIDE AVOIDANCE

Fratricide is defined as “the employment of friendly weapons, with the intent to kill the enemy or destroy his equipment and facilities, which results in unforeseen and unintentional death, injury, or damage to friendly, neutral, or noncombatant personnel.” It is a complex problem, old as warfare itself, that defies a simple solution.

CONTENTS	
PARAGRAPH	PAGE
H-1 Magnitude of the Problem	H-1
H-2 Situational Awareness	H-1
H-3 Risk Assessment	H-2
H-4 Preventive Measures	H-4
H-5 Role of Graphics	H-4
H-6 Briefbacks and Rehearsals	H-5
H-7 Response to a Friendly Fire Control	H-5

H-1. MAGNITUDE OF THE PROBLEM

The rapid, nonlinear modern battlefield creates command and control challenges for every leader. For example, thermal imagery devices and accurate, lethal weapons enable soldiers to acquire, engage, and destroy targets at extended ranges. However, even these sophisticated tools do not allow positive identification of targets by visual means alone beyond about 1,000 meters, and even within this range, the intensity and the clarity of the thermal image is often degraded by rain, dust, fog, smoke, snow, or other battlefield obscuring factors. This example is only one of how fratricide incidents could occur; leaders and soldiers *must* maintain constant situational awareness throughout every operation.

H-2. SITUATIONAL AWARENESS

In order to avoid fratricide, all leaders must develop techniques for maintaining situational awareness, and they must include these techniques in their SOPs. Examples of techniques that might be useful include—

- Monitoring on the next higher net.
- Listening to radio cross talk between units.

- Accurately reporting and navigating between positions.
- Training, using, and exchanging liaison officers.

H-3. RISK ASSESSMENT

Leaders at every level must identify fratricide risk factors and communicate them up and down the chain of command. Figure H-1 shows an example work sheet for computing fratricide risk in the context of mission requirements. The work sheet divides six mission-accomplishment areas into specific factors whose potential effect on the risk of fratricide is assessed as low (1 point), medium (2 points), or high (3 points). The column total is compared to the chart at the bottom of the example work sheet to determine the relative likelihood of fratricide. However, the commander bases his final assessment both on observable risk factors like the ones on the work sheet, and on his feelings about other, less tangible factors. This work sheet is a training tool for sensitizing chains of command to potential fratricide situations. As units become proficient with the checklist, the checklist will be a quick mental exercise to be carried over to combat operations.

	FACTORS	RATINGS SCALES	RISK LEVEL
SUBORDINATES' UNDERSTANDING OF PLAN	Commander's intent	(1) Clear Unclear (3)	1
	Complexity of plan	(1) Simple Complex (3)	3
	Enemy situation	(1) Known Unknown (3)	2
	Friendly situation	(1) Clear Unclear (3)	1
	Rules of Engagement	(1) Clear Unclear (3)	1
ENVIRONMENT	Visibility between units	(1) Favorable Unfavorable (3)	3
	Battlefield visibility	(1) Clear Obscured (3)	2
	Battle tempo	(1) Slow Fast (3)	1
	Target ID	(1) Positive ID No ID (3)	1
CONTROL MEASURES	Command relationships	(1) Organic Joint or combined (3)	2
	Audio	(1) Loud and clear Jammed (3)	1
	Visual	(1) Clearly visible Obscured (3)	3
	Graphics	(1) Clear Not understood (3)	1
	SOPs	(1) Used Not used (3)	1
	Liaison officers	(1) Proficient Untrained (3)	1
	Location and navigation	(1) Accurate Questionable (3)	3
EQUIPMENT (compared to US)	Friendly equipment	(1) Similar Different (3)	3
	Enemy equipment	(1) Different Similar (3)	1
TRAINING LEVELS	Individual proficiency	(1) MOS qualified Untrained (3)	1
	Unit proficiency	(1) Trained Untrained (3)	1
	Rehearsals	(1) Multiple None (3)	1
	Habitual relationship	(1) Yes No (3)	3
	Endurance	(1) Alert Fatigued (3)	1
PLANNING TIME AVAILABLE (1/3 to 2/3 Rule)	Higher HQ	(1) Adequate Inadequate (3)	2
	Own HQ	(1) Adequate Inadequate (3)	2
	Lower HQ	(1) Adequate Inadequate (3)	2
TOTAL RISK ASSESSMENT		26 to 46 points – LOW RISK 42 to 62 points – MEDIUM RISK 58 to 78 points – HIGH RISK	44

Figure H-1. Example fratricide risk assessment work sheet.

H-4. PREVENTIVE MEASURES

Avoiding fratricide begins with planning and continues throughout execution. Figure H-2, (page H-6), is a checklist of planning considerations for leaders and soldiers. These considerations are not directive in nature nor are they intended to restrict initiative. Figure H-3 asks questions an OPORD should answer in order to help avoid fratricide.

- a. **Planning.** A good plan clearly explains the enemy situation, the friendly situation, and the commander's intent, which helps avoid fratricide. Commanders may consider the status of each of the following to help determine the potential for fratricide:
 - Clarity of the enemy situation.
 - Clarity of the friendly situation.
 - Clarity of the commander's intent.
 - Complexity of the operation.
 - Planning time available to all levels.

- b. **Preparation.** During this phase, commanders must consider other indicators of fratricide risk:
 - The number and type of rehearsals.
 - The level of training and proficiency of the unit and of the individual soldiers.
 - The soldiers' endurance levels.
 - The habitual relationships between the units conducting the operation.

- c. **Execution.** An in-stride risk assessment and reaction are necessary to avoid situations that may pose unforeseen fratricide risk. Commanders must consider the following:
 - Visibility between adjacent units.
 - Battlefield obscuration factors and the ability to positively identify targets.
 - Similarities and dissimilarities between friendly and enemy equipment.
 - Density of vehicles on the battlefield.
 - Tempo of the battle.

H-5. ROLE OF GRAPHICS

To use graphics to clarify their intent, to add precision to their concept, to communicate their plan to subordinates, and to *avoid fratricide*, commanders at

all levels must understand what operational graphics are, and when and how to use them (FM 101-5-1).

H-6. BRIEFBACKS AND REHEARSALS

Briefbacks and rehearsals are useful in identifying planning errors.

- a. **Briefbacks.** Commanders' briefbacks ensure subordinates understand their intents. Commanders use briefbacks to inform their subordinates where fratricide risks may exist, then tell them how to reduce or eliminate those risks. They also briefback complex plans to eliminate any confusion that could otherwise contribute to fratricide.
- b. **Rehearsals.** The type of rehearsal conducted determines in part what risks are identified. Ideally, rehearsals should extend to all levels of command and involve all key players.

H-7. RESPONSE TO A FRIENDLY FIRE INCIDENT

Leaders and soldiers have specific and immediate responsibilities in the event of a friendly fire incident. Leaders must identify and stop the incident, assess the risk of its recurrence, and establish controls to prevent it. Crew responsibilities are as follows:

- a. **When a Crew Engages a Friendly Force.** As soon as a crew realizes they have engaged a friendly force, they must—
 - (1) Cease fire.
 - (2) Report on the next higher net, including the identity of the friendly force, if known; if not, they at least report the number and type of vehicles in the force, its location, the direction and distance to the victims, the type of fire used, and the target effects.
- b. **When a Crew Observes a Friendly Fire Incident.** If a crew sees someone else engage a friendly force, they must—
 - (1) Seek cover and protect themselves.
 - (2) Report on the next higher net, just as if they had engaged the friendly force themselves, except they also provide the direction and distance to the firer.
 - (3) Provide a visual friendly recognition signal.
 - (4) Provide assistance, once doing so is safe.

- Identify or assess potential fratricide risk in the estimate of the situation, and express it in the OPORD or FRAGO.
- Maintain situational awareness: current intelligence, unit locations or dispositions, denial areas (minefield or FASCAM), contaminated areas such as ICM or NBC, SITREPs, and METT-T.
- Ensure positive target identification. Review vehicle and weapon ID cards; know how far and in what conditions vehicles or weapons can be positively identified.
- Enforce avoidance measures such as constant supervision of the execution of orders and performance to standard through the use of doctrinally sound tactics.
- Recognize the signs of battlefield stress. Deal with it quickly and effectively to maintain unit cohesion.
- Conduct individual and collective (unit) fratricide awareness training, target identification or recognition, fire discipline, and leader training.
- Develop a simple, decisive plan.
- Give complete and concise mission orders.
- Ensure SOPs are consistent with doctrine in order to simplify mission orders. Periodically review and change them as needed.
- Allow as much planning time as possible for you and your subordinates.
- Use common language or vocabulary, including doctrinally correct standard terminology and control measures such as fire support coordination line (FSCL), zone of engagement, and restrictive fire line (RFL).
- Ensure coordination is thorough.
- Plan or establish good communications.
- Plan collocated CPs, if appropriate to the mission.
- Establish liaison as appropriate.
- Ensure the ROE are clearly understood.
- Consider the effects of fratricide on key elements of terrain analysis (OCOKA).
- Rehearse whenever the situation allows.
- Use position locating and navigating devices (GPS); know where you are and where adjacent units are (left, right, leading, and following-on), and synchronize tactical movement.
- Include fratricide incidents in AARs.

Figure H-2. Planning considerations for fratricide avoidance.

1. SITUATION**a. Enemy Forces.**

- Where are the enemy forces?
- What similarities exist between enemy and friendly equipment that could lead to fratricide?
- What is the enemy's deception history and capability?
- What languages do enemy forces speak, and could these increase the risk of fratricide?

b. Friendly Forces.

- What differences in language, uniform, or equipment exist between friendly forces that could lead to fratricide during any *combined* or *joint* operation?
- What is the friendly deception plan?
- Where are adjacent units (left or right, leading, or following-on)?
- Where are neutral and noncombatant personnel?

c. Own Forces.

- What are the levels of proficiency of individual soldiers, crews, and your unit as a whole?
- Will fatigue be a factor during the operation, and have you prepared an effective sleep plan?
- Is your unit acclimatized to the area of operations?
- What is the status of training on any new equipment, and how old is rest of the equipment?
- What MOPP requirements will apply to the operation?

d. Attachments and Detachments.

- Have attached elements been provided with this information?
- Are detached elements provided this information by their gaining units?

e. Weather.

- What are the light and precipitation (visibility) conditions expected?
- What effect will the heat or cold have on soldiers, weapons and other equipment, and vehicles?

f. Terrain.

- Is the terrain urban, mountainous, hilly, rolling, flat, desert, swampy or marshy, prairie or steppe, jungle, densely forested, or openly wooded?
- Have you evaluated the terrain using the factors of OCOKA?

Figure H-3. Checklist of questions addressing fratricide avoidance.

2. MISSION

Are the mission and all its associated tasks and purposes clearly understood?

3. EXECUTION

a. Concept of the Operation.

(1) *Maneuver.* Are main and supporting efforts identified?

(2) *Fires.* (Direct and indirect)

– Are priorities of fire identified?

– Have target lists been developed?

– Have the fire execution matrix and overlay been developed?

– Have locations of denial areas (minefields—FASCAM) and contaminated areas (ICM, NBC) been identified?

– Are the locations of all supporting fires targets identified in the OPORD and OPLAN overlays?

– Are aviation and CAS targets clearly identified?

– Has the direct-fire plan been developed?

– Have FPF been designated?

(3) *Engineer tasks.*

– Where are friendly minefields, including ICM and FASCAM?

– Are obstacles identified, and what is the approximate time needed to reduce or breach each one?

(4) *Tasks to subordinate unit.* Are the appropriate friendly forces identified for each subordinate maneuver element?

(5) *Tasks to CS and CSS units.* Have locations of friendly forces been reported to CS and CSS units?

b. Task Organization.

– Has the unit worked under this task organization before?

– Are SOPs compatible with the task organization (especially with attached units)?

– Are special markings or signals, such as cats' eyes, chemical luminescent lights, or panels, needed in order to positively identify uniforms and equipment?

– What special weapons and equipment are to be used? Do they look or sound like enemy weapons or equipment?

c. Coordinating Instructions.

– Are direct and indirect fires included in the rehearsal?

– Is a briefback necessary?

Figure H-3. Checklist of questions addressing fratricide avoidance (continued).

- Are appropriate control measures clearly explained and illustrated in the OPORD and overlays? Have these measures been disseminated to everyone who has a need to know? How will they be used to synchronize the battle and prevent fratricide?
 - Have target and vehicle identification drills been practiced?
 - Do subordinate units know the immediate action drill or the signal to communicate "Cease fire" or "I am friendly," in case they should come under unknown or friendly fire? Do they know what to do if this does not work?
 - Is guidance included about handling dud munitions such as ICMs and CBUs?
- 4. SERVICE SUPPORT**
- Are train locations and ID markings known to everyone?
 - Do medical and maintenance personnel know the designated routes between trains and units?
- 5. COMMAND AND SIGNAL**
- a. Command.**
- (1) Where are the commander and key staff members?
 - (2) What is the chain of command?
- b. Signal.**
- (1) Do instructions include signals for special and emergency events?
 - (2) Do they address how to identify friendly forces to aircraft?
 - (3) Do they include backup code words and visual signals for all special and emergency events?
 - (4) Are SOI distributed to all units with a need-to-know such as higher, lower, adjacent, leading, and follow-on units?

Figure H-3. Checklist of questions addressing fratricide avoidance (continued).

* GLOSSARY

Acronyms and Abbreviations

A/L	administrative/logistics
AA	assembly area
AAR	after-action review
ACA	airspace coordination area
ACE	armored combat earthmover
AD	air defense
ADA	air defense artillery
AFV	armored fighting vehicle
AG	adjutant general
AI	area of interest
ALO	air liaison officer
ANGLICO	air naval gunfire liaison company
AO	area of operations
APC	armored personnel carrier
AR	Army regulation
ARSOTF	Army special operations task force
arty	artillery
ASP	ammunition supply point
AT	antitank
ATGM	antitank guided missile
atk	attack
ATKHB	attack helicopter battalion
ATP	ammunition transfer point
AVLB	armored vehicle-launched bridge
BAI	battlefield air interdiction
BAS	battalion aid station
bde	brigade

BFV	Bradley fighting vehicle
BHL	battle handover line
BICC	battalion information control center
BLPS	ballistic laser protection system
BMNT	beginning morning nautical twilight
BMO	battalion maintenance officer
BMP	(a Threat fighting vehicle)
bn	battalion
BP	battle position
BRMD	(a Threat scout car)
BSA	brigade support area
BTR	(a Threat vehicle)
C³CM	command, control, and communications countermeasures
CAS	close air support
cbt	combat
CBU	cluster bomb unit
CDR	commander
CEOI	communications-electronics operation instructions (this acronym has been replaced by "SOI," which is reflected in Change 1)
CESO	communications-electronia signal officer (this acronym has been replaced by "signal officer, which is reflected in Change 1)
CEV	combat engineer vehicle
CF	covering force
CFA	covering force area
CFFS	combat field feeding system
CFL	coordinated fire line
cGy	centigray(s)
CINC	Commander in Chief
CLAMS	cleared lane marking system
CLOS	cloud-free line of sight

CMT	company maintenance team
co	company
COA	course of action
COLT	combat observation/lasing team
COMMZ	communications zone
COMSEC	communications security
COP	command observation post (opposing forces)
COSCOM	corps support command
CP	command post
CS	combat support
CSM	command sergeant major
CSR	controlled supply rate
CSS	combat service support
CTA	common table of allowances
DA	Department of the Army
deploy	deployment
DEW	directed-energy weapons
DISCOM	division support command
div	division
DLIC	detachment(s) left in contact
DP	decision point
DPICM	dual-purpose improved conventional munition
DS	direct support
DSA	division support area
DTG	date-time group
DVOD	direct-view optical device
DZ	drop zone
EA	engagement area
ECM	electronic countermeasures
EPW	enemy prisoners of war

EW	electronic warfare
EXTAL	extra time allowance
FA	field artillery
FAC	forward air controller
FARP	forward area rearm/refuel point
FASCAM	family of scatterable mines
FCL	final coordination line
FCT	firepower control team
FD	fire direction
FDC	fire direction center
FEBA	forward edge of the battle area
FIST	fire support team
fld	field
FLOT	forward line of own troops
FM	field manual
FO	forward observer
FPF	final protective fires
FRAGO	fragmentary order
FS	fire support
FSB	forward support battalion
FSC	fire support coordination
FSCL	fire support coordination line
FSCoord	fire support coordinator
FSE	fire support element
FSO	fire support officer
FSS	fire support section
FSV	fire support vehicle
FTX	field training exercise
fwd	forward
G1	Personnel

G2	Intelligence
G3	Operations and Plans
G4	Logistics
G5	Civil Affairs
GEMSS	ground-emplaced mine scattering system
GLLD	ground laser location designator
GPS	Global Positioning System
GS	general support
GSR	ground surveillance radar
GTA	graphic training aid
HC	hexachloroethane (smoke grenade)
HE	high explosive
HEMMS	hand-emplaced minefield marking set
HEMTT	heavy expanded mobility tactical truck
HET	heavy equipment transporter
HHC	headquarters and headquarters company
HIMS	HMMWV interchangeable mount system
HMMWV	high-mobility multipurpose wheeled vehicle
HPM	high power microwave
HPT	high-payoff target
HQ	headquarters
HUMINT	human intelligence
hvy	heavy
IAW	in accordance with
ICM	improved conventional munitions
IDP	initial delay position
IEW	intelligence and electronic warfare
IPB	intelligence preparation of the battlefield
IR	intelligence requirements
ITV	improved TOW vehicle

JAAT	joint air attack team
km	kilometer(s)
KM1H	kilometers traveled in an hour
kph	kilometers per hour
LAW	light antitank weapon
LC	line of contact
LD	line of departure
ldr	leader
LO	liaison officer
LOA	limit of advance
LOGPAC	logistics package
LRP	logistical release point
LZ	landing zone
M1H	miles traveled in an hour
MAB	mobile assault bridge
MANPADS	man-portable air defense system
MBA	main battle area
MC	mobility corridor
mech	mechanized
MEDEVAC	medical evacuation
METT-T	mission, enemy, terrain, troops, and time available
MG	machine gun
MGB	medium girder bridge
MICLIC	mine-clearing line charge
MIJI	meaconing, intrusion, jamming, and interference
MLC	military load classification
MLRS	multiple-launch rocket system
mm	millimeter
mob	mobilization

MOIC	missile ordnance inhibit circuit
MOPP	mission-oriented protective posture
mort	mortar
MOUT	military operations on urbanized terrain
MPT	mobile pay team
MR	motorized rifle (opposing forces)
MRE	meal, ready-to-eat
MSB	main support battalion
MSE	mobile subscriber equipment
MSR	main supply route
MST	maintenance support team
MTMC	Military Traffic Management Control
MTOE	modified table of organization and equipment
NAI	named areas of interest
NATO	North Atlantic Treaty Organization
NBC	nuclear, biological, chemical
NCA	national command authority
NCO	noncommissioned officer
NCOIC	noncommissioned officer in charge
NCS	net control station
NGF	naval gunfire
NLT	not later than
NO	number
NVD	night vision device
O&I	operation and intelligence
OAKOC	obstacles and movement, avenues of approach, key terrain, observation and fields of fire, and cover and concealment
OAS	offensive air support
OB	order of battle
OBJ	objective

OCOKA	observation and fields of fire, cover and concealment, obstacles, key terrain, and avenue of approach (this acronym has been replaced by "OAKOC," which is reflected in Change 1)
OEG	operational exposure guidance
OFF	officer
OIC	officer in charge
OP	observation post
OPCON	operational control
OPLAN	operation plan
OPORD	operation order
OPSEC	operations security
P&A	personnel and administration
PA	physician's assistant
PAC	personnel and administration center
PADS	position and azimuth determining system
PAO	public affairs officer
PDDA	power-driven decontaminating apparatus
PIR	priority intelligence requirements
PL	phase line
PLD	probable line of deployment
PLL	prescribed load list
plt	platoon
PMCS	preventive maintenance checks and services
POL	petroleum, oils, and lubricants
PP	passage point
PSNCO	personnel staff noncommissioned officer
PSS	personnel support system
PST	pass time
PSYOP	psychological operations
PW	prisoner of war

PX	post exchange
PZ	pickup zone
R&S	reconnaissance and security
RATT	radio teletypewriter
RB	ribbon bridge
recon	reconnaissance
regt	regiment
REMS	remotely employed sensor
res	reserve(s)
RF	radio frequency
RFA	restrictive fire area
RFL	restrictive fire line
ROE	rules of engagement
RP	release point
RRP	replacement receiving point
RSR	required supply rate
RTE	route
S1	Adjutant
S2	Intelligence Officer
S3	Operations and Training Officer
S3 Air	Assistant S3, Air Operations
S4	Supply Officer
S5	Civil Affairs Officer
SALT	supporting arms liaison team
SALUTE	size, activity, location, unit, time, and equipment
sct	scout
SEAD	suppression of enemy air defense
SEE	small emplacement excavator
SFCP	shore fire control party
SFOD	special forces operational detachment

sig	signal
SIGINT	signal intelligence
SIGSEC	signal security
SITREP	situation report
SOCCE	special operations command and control element
SOF	special operations force
SOI	signal operation instructions
SOP	standing operating procedure
SP	start point
SP4	specialist fourth class
spt	support
sqd	squad
SSN	Social Security Number
STANAG	Standardization Agreement
STRIKWARN	strike warning
STX	situational training exercise
TAC	Tactical Air Command
TACC	tactical air control center
TACCS	Tactical Army Combat Service Support (CSS) Computer System
TACFAX	tactical facsimile
TACP	tactical air control party
TAI	target areas of interest
TAMMS	The Army Maintenance Management System
TC	training circular
TDIS	time distance
TF	task force
tgt	target
thru	through
TIWD	terrain influenced wind direction
tm	team

TM	technical manual
TOC	tactical operations center
TOT	time on target
TOW	tube-launched, optically tracked, wire guided
TRADOC	Training and Doctrine Command (United States Army)
TRP	target reference point
TTP	tactics, techniques, and procedures
TTS	tank thermal sight
UHF	ultra high frequency
UMCP	unit maintenance collection point
US	United States
USAF	United States Air Force
VEESS	vehicle engine exhaust smoke system
veh	vehicle
VPKM	vehicles per kilometer
VPM	vehicles per mile
VT	variable time
VTR	vehicle, tracked, recovery
WP	white phosphorus
XO	executive officer

* REFERENCES

Required Publications

Required publications are sources that users must read in order to understand or to comply with this publication.

FIELD MANUALS (FMs)

- 71-1 Tank and Mechanized Infantry Company Team
- * 71-3 Armor and Mechanized Infantry Brigade
- 100-5 Operations
- 101-5 Staff Organization and Operations
- 101-5-1 Operational Terms and Symbols

* GRAPHIC TRAINING AIDS (GTAs)

- 3-6-3 NBC Warning and Reporting System

Related Publications

Related publications are sources of additional information. They are not required in order to understand this publication.

FIELD MANUALS (FMs)

- * 1-100 Doctrinal Principles for Army Aviation in Combat Operations
- * 1-112 Tactics, Techniques, and Procedures for the Attack Helicopter Battalion
- * 3-3 Chemical and Biological Contamination Avoidance
- 3-4 NBC Protection
- 3-5 NBC Decontamination
- 3-6 Field Behavior of NBC Agents (Including Smoke and Incendiaries)
- * 3-9 Potential Military Chemical/Biological Agents and Compounds
- * 3-100 NBC Defense, Chemical Warfare, Smoke, and Flame Operations
- * 5-36 Route Reconnaissance and Classification
- 5-100 Engineer Combat Operations
- 5-101 Mobility
- 5-102 Countermobility
- 5-103 Survivability
- * 5-250 Explosives and Demolitions
- * 6-20 Fire Support in the Airland Battle
- * 6-20-40 Tactics, Techniques, and Procedures for Fire Support for Brigade Operations
- * 7-20 The Infantry Battalion

7-90	Tactical Employment of Mortars
7-91	Tactical Employment of Antiarmor Platoons, Companies, and Battalions
10-63-1	Graves Registration Handbook
17-12-1	Tank Combat Tables, M1
17-12-3	Tank Combat Tables, M60A3
17-98	Scout Platoon
21-10	Field Hygiene and Sanitation
21-75	Combat Skills of the Soldier
23-1	Bradley Fighting Vehicle Gunnery
* 23-10	Sniper Training
* 23-14	M249 Light Machine Gun in the Automatic Rifle Role
* 23-34	TOW Weapon System
34-3	Intelligence Analysis
* 34-81	Weather Support for Army Tactical Operations
44-3	Air Defense Artillery Employment: Chaparral/Vulcan/Stinger
44-8	Small Unit Self-Defense Against Air Attack
44-16	Chaparral/Vulcan/Stinger Platoon Combat Operations
55-9	Unit Air Movement Planning
55-12	Movement of Units in Air Force Aircraft
55-20	Army Rail Transport Units and Operations
* 55-65	Strategic Deployment by Surface Transportation
71-100	Armored and Mechanized Division Operations
* 71-100-2	Infantry Division Operations, Tactics, Techniques, and Procedures
* 90.2	Battlefield Deception
* 90.3	Desert Operations
* 90-5	Jungle Operations
90-6	Mountain Operations
90-10 (HTF)	Military Operations on Urbanized Terrain (MOUT) (How to Fight)
* 90-10-1	An Infantryman's Guide to Combat in Built-Up Areas
* 90-13	River Crossing Operations
100-2-1	Soviet Army Operations and Tactics
100-2-3	The Soviet Army Troops, Organization, and Equipment
100-27	US Army/US Air Force Doctrine for Joint Airborne and Tactical Airlift Operations
101-10-1	Staff Officers' Field Manual: Organizational, Technical and Logistical Data (Unclassified Data)

QSTAG

- 506 Operation Orders, Warning Orders, and Admin/
Logistics Orders
- 567 Infantry Battalion Antiarmor Weapons

STANAG

- 2014 Operations Orders, Annexes to Operations Orders,
Administrative and Logistics Orders
- 2041 Road Movement
- 2082 Relief of Combat Troops
- 2129 Recognition and Identification of Land Forces on the
Battlefield

TRAINING CIRCULAR (TC)

- 6-71 Fire Support Handbook for the Maneuver Commander

INDEX

- administrative/logistics net, 2-30
- advance guard, 3-45, 5-52
- air defense, 1-12
- air defense artillery, 1-10, 3-31, 3-47, 3-52, 3-57, 4-19, 4-25
- air defense artillery officer, 2-7
- air defense support, 6-24
 - active, 6-24
 - early warning, 6-26
 - employment considerations, 6-27
 - missions, 6-25
 - passive, 6-24
 - systems, 6-25
 - weapons control, 6-26
- AirLand Battle operations, 1-4
 - characteristics of, 1-4
- alternate main command post, 2-8
- antiarmor company, 3-51, 3-56
- Army aviation support, 3-31, 6-22
 - assets, 6-22
 - attack helicopters, synchronization of, 6-22
- assault
 - dismounted, 3-37
 - mounted, 3-37
- assembly areas
 - departing from, C-26
 - organization, C-25
 - quartering party, C-24
- assistant S3/chemical officer, 2-5
- attack. *See also* offense.
 - by fire, 3-32
 - deliberate, 3-52
 - from a defensive posture, 3-64
 - frontal, 3-9
 - hasty, 3-49
 - main, 3-25
 - night, 3-32
 - of a strongpoint, 3-58
 - spoiling, 3-66
 - supporting, 3-26
- attack by fire, 3-27
- attack helicopter support, 3-29, 4-24, 6-22

- battalion chaplain, 2-6

- battalion commander, 1-7
- battalion signal officer, 2-6
- battalion surgeon, 2-6
- battalion maintenance officer, 2-5
- battalion task force
 - capabilities, 1-2
 - limitations, 1-3
 - mission, 1-2
 - reserve, 3-27
 - commitment, 3-28
 - composition, 3-28
 - location, 3-28
 - size, 3-28
- battalion task force commander, 2-2
- battalion task force reserve, 3-27
- battle handover, 4-27
- battle position, 4-37
- battlefield operating systems, 1-10
 - air defense, 1-12
 - combat service support, 1-13
 - command and control, 1-10
 - fire support, 1-11
 - intelligence, 1-12
 - maneuver, 1-11
 - mobility, countermobility, survivability, 1-12
- breakout from encirclement
 - conduct of, 5-37
 - planning, 5-34
 - purpose, 5-33
- bypass operations, 3-35, 3-49

- cannon field artillery, 1-10, 3-29, 3-46, 3-56, 4-25
- close air support, 1-10, 1-11, 3-30, 3-46, 3-52, 6-19
- close operations, 4-6
 - main battle area, 4-6
 - reserve, 4-7
 - security area, 4-6
- cold weather operations, 1-15
- combat orders
 - essential characteristics, B-4
 - fragmentary order, B-57
 - overlays, B-17
 - task force execution matrix, B-18
 - types of, B-2
 - warning order, B-19
- combat service support, 1-13, 3-31, 3-52, 3-57, 4-26, A-3
 - command and control, 7-22

Index-2

- communications, 7-23
- cross-attachments, 7-18
- LOGPACs, 7-14
- task force trains, 7-12
- trains security, 7-22
- combat support, 1-9, 1-10, 4-16, 6-3
 - air defense artillery, 1-10, 6-24
 - cannon field artillery, 1-10
 - close air support, 1-10
 - engineer, 1-10
 - military intelligence, 1-10
- combat trains command post, 2-9, 3-31
- command and control, 1-10, 2-2, 2-11, 5-21, 7-22, A-2
 - decision-making, 2-14
 - factors of METT-T, 2-12
 - organization, 2-2
 - planning, 2-11
 - troop-leading procedures, 2-14
- command group, 2-9
- command net, 2-30
- command post
 - alternate main, 2-8
 - combat trains, 2-9
 - field trains, 2-9
 - main, 2-8
 - tactical, 2-8
- command sergeant major, 2-4
- communications nets
 - administrative/logistics, 2-30
 - command, 2-30
 - operation and intelligence, 2-30
 - radio, 2-30
- communications platoon, 1-9
- communications security, 2-32
- company team mission, 3-27
- command and control, 1-10
- command and support relationships, 6-2
- concept of operation, 3-22
 - fires, 3-24
 - maneuver, 3-23
- consolidation and reorganization, 3-38, 6-45
- control measures, 3-39
 - assault positions, 3-41
 - attack positions, 3-41
 - attack-by-fire position, 3-41
 - axis of advance, 3-40
 - checkpoints, 3-42

- direction of attack, 3-40
- final coordination line, 3-41
- infiltration lane, 3-41
- limit of advance, 3-41
- line of departure, 3-41
- objective, 3-39
- overwatch position, 3-41
- phase line, 3-41
- techniques while moving, 3-42
- zone of action, 3-40
- coordinating staff, 2-4
- counterattack, 3-65, 4-42
- countermobility, 1-12, 3-31, 3-52, 3-57, 4-17, 4-25, 6-29
- counterreconnaissance operations, 4-47

- decision-making process, 2-14
- deep operations, 4-6
- defense, 3-47
 - battle handover, 4-27
 - close operations, 4-6
 - combat support of, 4-16
 - control measures, 4-20
 - counterreconnaissance operations, 4-47
 - deep operations, 4-7
 - planning, 4-8
 - rear operations, 4-7
 - reserve operations, 4-42
 - security, 4-19
 - types of, 4-30
 - urban area operations, 4-61
- deliberate attack, 3-52
 - techniques for, 3-54
- demonstration operations, 3-69
- desert operations, 1-14
- direct fire, 3-34
- directed energy weapons
 - actions under attack, D-4
 - electronic, D-3
 - laser, D-2
 - planning measures, D-3
 - types of, D-1

- eavesdrop system, 2-31
- engineer, 2-7
- engineers, 1-10, 1-12, 3-31, 3-52, 4-17, 4-25, 5-47, 6-29
- envelopment, 3-5, 6-44

- executive officer, 2-3
- exploitation, 3-62, 6-45

- feint, 3-69
- field services
 - airdrop/airlift, 7-34
 - clothing exchange and bath, 7-34
 - graves registration, 7-33
 - laundry and renovation, 7-34
 - salvage, 7-34
- field trains command post, 2-9
- fire control, 2-34
- fire support, 1-11, 3-24, 3-27, 3-52, 3-56, 4-16, 4-25, 5-22, A-2
- fire support officer, 2-7
- flank guard, 3-46, 5-54
- follow-and-support forces, 3-66
- forward air controller, 2-7
- forward passage, 5-26
- frontal attack, 3-9

- ground surveillance radar, 3-20, 3-21, 3-30, 3-47, 4-48, 5-51, 6-42
- guard operations
 - conduct of, 5-52
 - purpose, 5-51
 - types of, 5-51

- hasty ambush, 3-49
- hasty attack, 3-49
 - against moving force, 3-49
 - against stationary force, 3-51
- hasty water crossings
 - characteristics, 5-44
 - conduct of, 5-47
 - planning, 5-44
 - purpose, 5-44
- headquarters and headquarters company commander, 2-6
- heavy forces
 - defense missions, A-3
 - offense missions, A-5

- indirect fire support, 6-3
- infiltration, 3-9, 6-45
- intelligence, 1-12, 3-30, 3-52, 4-25, A-3
- intelligence and electronic warfare support, 6-41
- intelligence preparation of the battlefield, 2-23
 - defensive, 4-11
 - functions, 2-23

- offensive, 3-19
- purpose, 2-23

- joint air attack team, 6-21
- jungle operations, 1-14

- light-heavy forces
 - defense, A-5
 - offense, A-3
- limited visibility, 4-23
- linkup operations, 5-39
 - conduct of, 5-39
 - planning, 5-39
 - purpose, 5-39
- LOGPAC operations, 2-10, 7-14

- main attack, 3-25, 3-56
- main battle area operations, 4-6
- main body, 3-45
- main command post, 2-8
- maintenance platoon, 1-9, 3-32, 3-47, 7-6
- maneuver, 1-11, 3-5, 3-23, 3-28, 3-51, 3-56, 4-24, A-2
- mechanized infantry battalion
 - mission, 1-2
- medical platoon, 1-9, 3-32, 3-47, 3-52, 7-5
- military intelligence, 1-10
- mobility, 1-12, 3-31, 3-52, 3-57, 4-17, 4-25, 5-3, 6-29
- mortar platoon, 1-9, 3-30, 3-46, 3-52, 3-57, 4-25, 6-16
- mountain operations, 1-14
- movement formations, 3-10
 - box, 3-15
 - column, 3-10
 - diamond, 3-15
 - echelon, 3-14
 - line, 3-14
 - V, 3-13
 - wedge, 3-12
- movement to contact, 3-42, 6-44
- movement techniques, 3-10

- naval gunfire, 6-17
- night attack, 3-32
- nuclear, biological, and chemical, 1-12, 3-31, 3-52, 4-19, 4-26
- nuclear, biological, and chemical battlefield
 - avoidance of contamination, E-7
 - decontamination, E-10, E-11
 - defend against chemical attack, E-7

Index-6

- defend against biological attack, E-8
- mission-oriented protection posture, E-9
- operation exposure guide, E-5
- protection, E-3
- radiological monitoring, E-4
- radiological survey, E-5
- support, 6-32
- warning and reporting system, E-6

obstacles, 5-60

- breaching, 5-60
 - deliberate, 5-62
 - hasty, 5-61
- bypassing, 5-60

offense, 3-2

- characteristics, 3-2
- consolidation and reorganization, 3-38
- control measure, 3-39
- purpose, 3-2
- types of, 3-4

operation and intelligence net, 2-30

operations security, 2-33

passage of lines

- forward, 5-26
- planning considerations, 5-21
- purpose, 5-20
- rearward, 5-23

penetration, 3-7, 6-44

perimeter defense, 4-55

pursuit, 3-4, 3-63, 6-45

radio nets, 2-30

raid, 3-67

rear guard, 3-46, 5-58

rear operations, 4-7, 4-46

rearward passage, 5-23

reconnaissance, 3-4, 3-58, 5-22

reconnaissance and surveillance, 3-19

reconnaissance in force, 3-64

relief operations

- conduct of, 5-29
- purpose, 5-28
- types of, 5-28

remote sensor teams, 3-20, 3-21

reserve operations, 3-36, 4-7, 4-42

- retrograde operations
 - delay, 5-4
 - planning, 5-3
 - retirement, 5-20
 - withdrawal, 5-13
 - not under pressure, 5-13
 - under pressure, 5-16
- reverse slope defense, 4-57

- S1 (adjutant), 2-4
- S2 (intelligence), 2-4
- S3 (operations and training officer), 2-4
- S3 Air, 2-5
- S4 (logistics officer), 2-5
- scout platoon, 1-8, 3-29, 3-46, 3-51, 3-56, 4-24
- security area operations, 4-6
- security force, 3-44
- smoke employment, 6-33
- stay-behind/hide forces, 4-50
- supply operations, 7-24
- support platoon, 1-9, 3-32, 3-47, 4-26, 7-6
- supporting attack, 3-26, 3-56
- survivability, 1-12, 3-36, 3-52, 3-57, 4-17, 4-25, 6-29

- tactical air support, 6-17
- tactical command post, 2-8
- tactical road marches
 - control measures, C-8
 - march order, C-5
 - movement formulas, C-11
 - movement table, C-14
 - organization for, C-3
 - planning, C-5, C-6
 - security, C-14
 - techniques, C-9
 - types of movement, C-1

- tank battalion
 - mission, 1-2
- target reference point, 4-20
- task force trains, 7-12
- terrain analysis, 2-13, 2-23
- Threat
 - defense, 3-16
 - offense, 4-7, 4-8
- troop-leading procedures, 2-44
- turning movement, 3-6

Index-8

urban area operations, 1-14, 4-61

weapons control, 6-26

weather analysis, 2-24

FM 71-2
27 SEPTEMBER 1988

By Order of the Secretary of the Army:

CARLE E. VUONO
General, United States Army
Chief of Staff

Official:

WILLIAM J. MEEHAN II
Brigadier General, United States Army
The Adjutant General

DISTRIBUTION:

Active Army, USAR, and ARNG: To be distributed in accordance with DA Form 12-11A, Requirements for Tank and Mechanized Infantry Battalion Task Force (Qty rqr block no. 506).

*U.S. Government Printing Office: 1992-311-831/61258